

**To:** Lea Boyle  
Puget Sound Energy  
PO Box 90868, EST-06E  
Bellevue, Washington 98009-9734

**Date:** 2/12/2009

**File:** 00186-634-03

**Email Address:** lea.boyle@pse.com

**Regarding:** Upper Baker Generation Plant

Date	Description
8/28/2008	Final SPCC Plan (PDF and Word)

**Remarks:** Please call if you have questions.

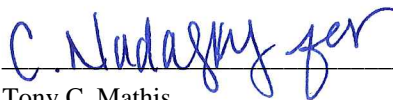
Signed:   
Tony C. Mathis  
tmathis@geoengineers.com

DISCLAIMER: This document and any attachments are confidential and intended solely for the use of the individual or entity to whom they are addressed. Any electronic form, facsimile or hard copy of the original document (email, text, table, and/or figure), if provided, and any attachments are only a copy of the original document. The original document is stored by GeoEngineers, Inc. and will serve as the official document of record.



**SPILL PREVENTION, CONTROL AND  
COUNTERMEASURE PLAN  
UPPER BAKER GENERATION PLANT  
47256 BAKER DAM ROAD  
CONCRETE, WASHINGTON**

**AUGUST 28, 2008**

**FOR  
PUGET SOUND ENERGY**



August 28, 2008

Puget Sound Energy  
P.O. Box 90868 PSE-11N  
Bellevue, Washington 98009-0868

Attention: John Rork

Subject: Spill Prevention, Control and Countermeasure Plan  
Upper Baker Generation Plant  
47256 Baker Dam Road  
Concrete, Washington  
File No. 0186-634-03

GeoEngineers is pleased to submit the Spill Prevention, Control and Countermeasure (SPCC) Plan for Puget Sound Energy, Upper Baker Generation Plant, 47256 Baker Dam Road, Concrete, Washington. Our services were completed in general accordance with our agreement with Puget Sound Energy (Contract No. 4600001763).

This SPCC Plan has been prepared for the exclusive use by Puget Sound Energy, their authorized agents and regulatory agencies. This Plan is not intended for use by others, and the information contained herein is not applicable to other sites. Within the limitations of scope, schedule, and budget, our services have been executed in accordance with the generally accepted engineering practices for SPCC plans in this area at the time this Plan was prepared. No warranty or other conditions express or implied should be understood.

We appreciate the opportunity to assist Puget Sound Energy on this project. Please contact us if you have questions regarding this report.

Yours very truly,

GeoEngineers, Inc.

Kurt R. Fraese, LG  
Principal

TCM:KRF:tt  
TACO:\0\0186634\03\Finals\018663403SPCCPlan\_UpperBaker.doc

**Spill Prevention, Control and  
Countermeasure Plan  
Upper Baker Generation Plant  
File No. 0186-634-03**

**August 28, 2008**

**Prepared for:**

**Puget Sound Energy  
P.O. Box 90868 PSE-11N  
Bellevue, Washington 98009-0868**

**Attention: John Rork**

**Prepared by:**

**GeoEngineers, Inc.  
1101 South Fawcett Avenue, Suite 200  
Tacoma, Washington 98402  
(253) 383-4940**

**GeoEngineers, Inc.**



**Tony C. Mathis, PE, LG, LHG  
Environmental Engineer**



**Kurt R. Fraese, LG  
Principal**

TCM:KRF:tt  
TACO:\0\0186634\03\Finals\018663403SPCCPlan\_UpperBaker.doc

Disclaimer: Any electronic form, facsimile or hard copy of the original document (email, text, table, and/or figure), if provided, and any attachments are only a copy of the original document. The original document is stored by GeoEngineers, Inc. and will serve as the official document of record.



**SPILL PREVENTION CONTROL AND COUNTERMEASURE PLAN  
MANAGEMENT APPROVAL AND CERTIFICATION**

**Original Plan Date:** August \_\_, 2008

**Plan Amendment/Recertification Date:**

**MANAGEMENT APPROVAL**

**This SPCC Plan Will Be Implemented As Described Herein:**

**NAME:** Edward R. Schild **SIGNATURE** \_\_\_\_\_

**TITLE:** Director of Energy Production & Storage **DATE:** \_\_\_\_\_

*Designated Person Accountable for Spill Prevention*

**NAME:** Gordie Johnston **SIGNATURE** \_\_\_\_\_

**TITLE:** Senior Environmental Scientist, Environmental Services **DATE:** \_\_\_\_\_

**ENGINEER'S CERTIFICATION  
(PART 112.3)**

I hereby certify that (i) I am familiar with the requirements of 40 CFR Part 112; (ii) That I or my agent have visited and examined the facility; (iii) That the Plan has been prepared in accordance with good engineering practice, including consideration of applicable industry standards, and with the requirements of this part; (iv) That procedures for required inspections and testing have been established; and (v) That the Plan is adequate for the facility.

Tony C. Mathis

\_\_\_\_\_  
Printed Name of Registered Professional Engineer

Tony C. Mathis  
Signature of Registered Professional Engineer

\_\_\_\_\_  
27707, Washington  
Registration No. State



**SPILL PREVENTION CONTROL AND COUNTERMEASURE PLAN  
SPCC PLAN REVIEW AND AMENDMENT  
(PART 112.5)**

In accordance with 40 CFR Part 112.5(b), a review and evaluation of this SPCC Plan will be conducted at least once every five years. As a result of this review and evaluation, Puget Sound Energy will amend the SPCC Plan within six months of the review to include more effective prevention and control technology if: 1) such technology will significantly reduce the likelihood of a spill event from the facility, and 2) such technology has been field-proven at the time of review. Any amendment to the SPCC Plan shall be certified by a Professional Engineer within six months after a change in the facility design, construction, operation, or maintenance occurs which materially affects the facility's potential for the discharge of oil into or upon the navigable waters of the United States or adjoining shorelines.

The undersigned individuals have completed a review and evaluation of the SPCC Plan for the Upper Baker Generation Plant, on the indicated date, and will amend the plan as described below.

**Designated Person Accountable for**

**Management Approval for Implementation Spill Prevention Review**

Signature: _____	Signature: _____
Name: <u>John Jensen</u>	Name: <u>Edward R. Schild</u>
Title: <u>Manager, Hydro Services</u>	Title: <u>Director of Energy Production &amp; Storage</u>
Review Date: _____	Review Date: _____

**Summary of SPCC Plan Amendments**

---

---

---

---

---

---

---

---

---

---

## TABLE OF CONTENTS

	<u>Page No.</u>
SPILL PREVENTION CONTROL AND COUNTERMEASURE PLAN MANAGEMENT APPROVAL AND CERTIFICATION .....	i
SPILL PREVENTION CONTROL AND COUNTERMEASURE PLAN SPCC PLAN REVIEW AND AMENDMENT (PART 112.5).....	ii
1.0 FACILITY INFORMATION AND CONTACTS (PART 112.7) .....	1
1.1 EMERGENCY CONTACTS AND NOTIFICATIONS (PART 112.7 (A)(3)(VI)) .....	1
1.2 SPILL REPORTING PROCEDURES (PART 112.7 (A)(4)) .....	3
1.3 NON-EMERGENCY FACILITY CONTACTS AND INFORMATION .....	4
2.0 REGULATORY AUTHORITY, DEFINITIONS, GENERAL REQUIREMENTS AND PURPOSE OF THE PLAN (PART 112.1, 112.2, 112.3(A) & (B), and 112.7) .....	5
2.1 PLAN ORGANIZATION AND CROSS REFERENCE (PART 112.7) .....	5
3.0 GENERAL FACILITY DESCRIPTION (PART 112.7) .....	8
3.1 COMPLIANCE WITH APPLICABLE SPCC REQUIREMENTS (PARTS 112.7 (A) AND 112.8 (A)) .....	8
3.2 LIST OF OIL STORAGE TANKS AND OIL-CONTAINING EQUIPMENT (PART 112.7 (A)(3)(I)).....	9
3.3 DESCRIPTION OF OIL STORAGE AND OIL-CONTAINING EQUIPMENT (PART 112.7 (A)(3)) .....	11
3.3.1 Generating Plant.....	11
3.3.2 Fuel Island Area .....	11
3.3.3 Depression Lake Pump Station Area .....	12
3.3.4 Glover Mountain Telecommunications Area .....	12
3.3.5 "Beach 3" Spawning Area.....	12
3.4 DRAINAGE PATHWAYS AND DISTANCE TO NAVIGABLE WATERS (PART 112.8(B)) .....	12
3.4.1 On-Site Drainage.....	12
3.4.2 Potential Off-Site Drainage Pathways .....	13
4.0 POTENTIAL SPILLS AND prevention measures .....	14
4.1 FAULT ANALYSIS – POTENTIAL SPILL EVENTS (PART 112.7(B)).....	14
4.2 OIL SPILL CONTAINMENT SYSTEMS (PART 112.7(C)).....	15
4.2.1 Generating Plant.....	15
4.2.2 Fuel Island Area .....	16
4.2.3 Depression Lake Pump Station Area .....	16
4.2.4 Glover Mountain Telecommunications Area .....	17
4.2.5 "Beach 3" Spawning Area.....	17
4.3 INSPECTIONS AND RECORD KEEPING (PART 112.7 (E)) .....	17
4.3.1 Oil Filled Electrical Equipment.....	17
4.3.2 Turbine Bearing System, Thrust and Guide at Generating Plant.....	18
4.3.3 Pump Bearing Systems at Depression Lake Pump Station Area .....	19

## TABLE OF CONTENTS (CONTINUED)

	<u>Page No.</u>
4.3.4 Aboveground Storage Tanks.....	19
4.3.5 Miscellaneous Oil Storage Areas .....	20
4.4 BRITTLE FRACTURE EVALUATION REQUIREMENTS (PART 112.7 (I)) .....	20
4.5 SECURITY (PART 112.7 (G)).....	20
5.0 TRAINING AND DISCHARGE PREVENTION PROCEDURES.....	21
5.1 TRAINING (PART 112.7 (F)) .....	21
5.2 OIL LOADING AND HANDLING PROCEDURES (PART 112.7 (A)(3)(III), PART 112.7 (H) AND PART 112.8 (D)).....	21
5.2.1 Transferring Fuel or Oil.....	21
5.2.2 Handling Oil-Filled Equipment.....	22
5.3 SIGNS, PLANS AND OIL CONTAINMENT KITS .....	22
5.3.1 Oil Spill Notification, Sign, and Plan Location .....	22
5.3.2 Oil Spill Containment Kits.....	22
6.0 SPILL EVENT: CONTAINMENT AND COUNTERMEASURE PROCEDURES (PART 112.7 (A)(3)(III) AND (IV)) .....	23
6.1 GENERAL PROCEDURES.....	23
6.1.1 Identification .....	23
6.1.2 Notification and Emergency Contacts .....	23
6.1.3 Containment .....	23
6.2 CLEANUP AND PCB SPECIAL HANDLING PROCEDURES (PART 112.7 (A)(3)(V)) .....	24
6.3 ASSESSING THE SPILL EVENT .....	24
6.4 REPORT REQUIREMENTS .....	25
6.4.1 Form .....	25
6.4.2 Notification.....	25
7.0 CONFORMANCE WITH STATE REQUIREMENTS (PART 112.7 (J)).....	26
8.0 PLAN AMENDMENT BY THE REGIONAL ADMINISTRATOR (PART 112.4).....	27

### List of Tables

Table 1. Plan Elements and Cross Reference to 40 CFR (Part 112).....	6
Table 2. Non-Electrical Oil-Containing Equipment .....	9
Table 3. Oil-Containing Electrical Equipment .....	10
Table 4. Potential Spill Events (Part 112.7(B)) .....	15

### List of Figures

- Figure 1. Vicinity Map
- Figures 2 and 3. Site Plan – Upper Baker Generation Plant
- Figure 4. Site Plan – Fuel Island Area
- Figure 5. Depression Lake Pump Station Area



## TABLE OF CONTENTS (CONTINUED)

### APPENDICES

APPENDIX A – CERTIFICATION OF THE APPLICABILITY OF THE SUBSTANTIAL  
HARM CRITERIA

APPENDIX B – PSE STANDARDS AND FORMS

- Oil Spill/SPCC/HAZ – Training Roster
- PSE Form 1184 – Spill Report Form
- PSE Form 1185 – Weekly Facility Inspection Form
- PSE Form 1364 – Monthly/Quarterly Facility Inspection Form
- PSE Standard Practice 0150.3100 – Cleanup of Oil Spills
- PSE Standard Practice 0150.3150 – Oil Sampling Procedures for Distribution  
Transformers and Oil-Filled Equipment
- Information Placard On Control Valve for Diked Secondary Containment Area

APPENDIX C – MAINTENANCE AND INSPECTION RECORDS

- Completed Weekly Facility Inspection Forms
- Completed Monthly Inspection Forms
- Completed Quarterly Inspection Forms
- Oil/Water Separator Maintenance Forms
- Other Operating Information as Appropriate

Puget Sound Energy  
Upper Baker Generation Plant  
47256 Baker Dam Road  
Concrete, Washington 98237

## 1.0 FACILITY INFORMATION AND CONTACTS (PART 112.7)

The facility described in this Plan is under the primary responsibility of Puget Sound Energy Power Production. All questions relating to this SPCC Plan or facility should be directed to the appropriate contacts listed in this section.

### 1.1 EMERGENCY CONTACTS AND NOTIFICATIONS (PART 112.7 (A)(3)(vi))

Local Emergency Services Telephone Number: 911 (9-911 from internal phones)

#### Puget Sound Energy Notifications

Name: Gordie Johnston

Title: Spill Response Coordinator

Contact Information: 24-Hour Spill Pager: (206) 994-3186\*

#### **\*Contact this Number First in the Event of a Spill**

Name: John Jensen

Title: Manager Hydro Services

Contact Information: Telephone: (360) 424-2910 (external)

86-2910 (internal)

Cell Phone: (360) 661-2280

Fax: (425) 462-3118

Name: Lynn Bell

Title: Maintenance Supervisor – Baker River Hydro

Contact Information: Telephone: (360) 853-8341 (external)

86-3042 (internal)

Cell Phone: (360) 305-0674

Puget Sound Energy  
Upper Baker Generation Plant  
47256 Baker Dam Road  
Concrete, Washington 98237

**Name:** Mike Kempkes

**Title:** Upper Baker Operator

**Contact Information:** Telephone: (360) 853-8608 (external)  
86-2033 (internal)

**Federal, State, and Local Emergency Contacts to be Notified**

**Federal Notifications**

**Name:** National Response Center

**Contact Information:** 24-hour Telephone: (800) 424-8802

**Washington State Notifications**

**Name:** Washington Division of Emergency Management

**Contact Information:** 24-hour Telephone: (800) 258-5990

## 1.2 SPILL REPORTING PROCEDURES (PART 112.7 (A)(4))

Contact the Spill Response Contractor at (206) 994-3186 first for assistance regarding a spill or suspected spill. Spills must be reported to appropriate Federal, State and local agencies if they result in a release of oil from the facility or produce a sheen or discoloration on the surface of an adjacent water body. The following information needs to be readily available when reporting a spill from the facility:

**Name of Facility:** Upper Baker Generation Plant

**Facility Main Telephone Number:** (360) 853-8341

**Location of Facility:** 47256 Baker Dam Road

Concrete, Washington 98237

**County:** Whatcom

**GPS Coordinates:** N 48° 39' 12"

W 121° 41' 36"

**Date and Time of Release:** \_\_\_\_\_

**Type of Material Released:** \_\_\_\_\_

**Estimated Quantity of Material Released:** \_\_\_\_\_

**Source of Material Released:** \_\_\_\_\_

**All Media Affected by Release:** \_\_\_\_\_

**Cause of Release:** \_\_\_\_\_

**Damages or Injury Cause by Release:** \_\_\_\_\_

**Actions Being Used to Control the Release:**  
\_\_\_\_\_  
\_\_\_\_\_

**Is an Evacuation Needed?:** \_\_\_\_\_

**People and Organizations that have been Contacted Regarding this Release:**  
\_\_\_\_\_  
\_\_\_\_\_

Puget Sound Energy  
Upper Baker Generation Plant  
47256 Baker Dam Road  
Concrete, Washington 98237

### 1.3 NON-EMERGENCY FACILITY CONTACTS AND INFORMATION

	<b>Facility Owner</b>	<b>Facility Operator</b>
<b>Name:</b>	Puget Sound Energy	Puget Sound Energy Upper Baker Generating Plant
<b>Address:</b>	P.O. Box 90868 PSE-11N	47256 Baker Dam Road
<b>City, State:</b>	Bellevue, Washington 98009	Concrete, Washington 98237
<b>Telephone:</b>	(425) 462-3552	(360) 853-8341

#### Environmental Services Department

**Name:** Gordie Johnston

**Title:** Senior Environmental Scientist, Spill Response Coordinator

**Contact Information:** Telephone: (360) 340-3716

Pager: (206) 994-3186

**Name:** John Rork – Puget Sound Energy

**Title:** Manager – Environmental Services

**Contact Information:** Telephone: (425) 456-2228

Cell Phone: (360) 340-3718



## **2.0 REGULATORY AUTHORITY, DEFINITIONS, GENERAL REQUIREMENTS AND PURPOSE OF THE PLAN (PART 112.1, 112.2, 112.3(A) & (B), AND 112.7)**

Regulations administered by the United States Protection Agency (EPA), and described in Title 40, Code of Federal Regulations, Part 112, dated July 17, 2002 (40 CFR, Part 112) require owners or operators of oil-handling or storage facilities to have Spill Prevention, Control and Countermeasure (SPCC) Plans in place to prevent the release of oil to navigable waterways. These requirements are applicable to non-transportation-related onshore or offshore facilities engaged in drilling, producing, gathering, storing, processing, refining, transferring, distributing, using, or consuming oil and oil products, which due to their location, could reasonably be expected to discharge oil in quantities that may be harmful into or upon the navigable waters of the United States or adjoining shorelines.

A SPCC Plan is a document that details the equipment, workforce, procedures, and steps to prevent, control, and provide adequate countermeasures to prevent the discharge of oil to navigable waters of the United States. The Plan must be prepared in writing and have the full approval of management at a level to commit the necessary resources to fully implement the Plan.

Oil is defined as oil in any form, including, but not limited to fats, oils, or greases of animal, fish, or marine mammal origin; vegetable oils, including oils from seeds, nuts, fruits, or kernels; and, other oils and greases, including petroleum, fuel oil, sludge, synthetic oils, mineral oils, oil refuse, or oil mixed with wastes other than dredged spoil.

These regulations apply to oil storage or handling facilities that are not transportation related, that have total aboveground oil storage of more than 1,320 gallons, or total belowground storage capacity of more than 42,000 gallons that is not regulated under a state program. Containers of less than 55-gallon capacity are not included in the calculation of the capacity of a facility. This facility exceeds the 1,320 gallon threshold requiring a SPCC Plan.

The compliance deadline for having an SPCC Plan in place that has been certified by a Professional Engineer (PE) and that is in conformance with the 2002 amendments to 40 CFR, Part 112 has been extended by the Environmental Protection Agency (EPA) as of May 2007. The new deadline for a facility SPCC plan to comply with the 2002 amendments to 40 CFR, Part 112 is July 1, 2009.

It is the policy of Puget Sound Energy and its contractors to recognize that oil contamination of the waters of the United States or the State of Washington is harmful. Therefore, it is required that emphasis be placed on oil spill prevention, and that appropriate engineering and safety procedures be used at all times when dealing with oil and its associated equipment.

### **2.1 PLAN ORGANIZATION AND CROSS REFERENCE (PART 112.7)**

This Plan contains the required elements of a SPCC Plan as described in 40 CFR, Part 112. The Plan has been organized to meet the requirement of 40 CFR Part 112.7 (a)(5) that it be readily usable in the event of an emergency. A cross reference of the sections of 40 CFR, Part 112, Subparts A and B to the sections contained in this document is included in this section. This cross reference also lists the facility characteristics that must be described in the Plan.

The requirements of § 112.9 through § 112.15 (portions of Subpart A and Subpart C) are not listed in this table. These requirements are for onshore oil production facilities or for facilities storing and handling

animal or vegetable oils, and are not applicable to this facility. Other information contained in the Plan includes the following:

- Appendix A includes a copy of the “Certification of the Applicability of the Substantial Harm Criteria,” as described in 40 CFR, Part 112, Appendix C. Based on the requirements listed on this checklist, the facility is not required to maintain a Facility Response Plan (FRP).
- Appendix B includes copies of PSE Standards and forms referenced in the SPCC Plan.
- Appendix C includes copies of inspection and maintenance records for the oil storage structures at the facility. This appendix will be maintained by the individual at the facility responsible for spill prevention.

**Table 1. Plan Elements and Cross Reference to 40 CFR (Part 112)**

<b>Section in 40 CFR Part 112</b>	<b>Description of Rule</b>	<b>Section in SPCC Plan</b>
§ 112.1	General Applicability	Section 2.0
§ 112.2	Definitions	Section 2.0
§ 112.3(a) & (b)	Requirement to Prepare and Implement a SPCC Plan	Section 2.0
§ 112.3(d)	Requirement to Prepare and Implement a SPCC Plan	Page i
§ 112.4	Amendment of SPCC Plan by Regional Administrator	Section 8.0
§ 112.5	Amendment of SPCC Plan by Owners or Operators	Page ii
§ 112.7	General requirements for SPCC Plans for all facilities and all oil types	Section 2.0
§ 112.7(a) (1) & (2) § 112.8(a)	Discussion of Facility's Conformance with Rules and Applicable Requirements of Subpart A and B and Deviations from the Plan Requirements	Section 3.1
§ 112.7(a) (3)	Site Description and Facility Diagram	Section 3.0 Figures 2 through 5
§ 112.7(a) (3)(i)	Type of Oil in Each Container & Storage Capacity	Section 3.2
§ 112.7(a) (3)(ii)	Discharge Prevention Measures – Procedures	Section 5.2
§ 112.7(a) (3)(iii)	Discharge or Drainage Controls – Secondary Containment	Section 4.2
§ 112.7(a) (3)(iii)	Discharge or Drainage Controls – Procedures to Control Discharges	Section 6.0
§ 112.7(a) (3)(iv)	Countermeasures for Discharge Discovery, Response and Cleanup for Facility Personnel and Cleanup Contractor	Section 6.0
§ 112.7(a) (3)(v)	Methods of Disposal of Recovered Materials	Section 6.2
§ 112.7(a) (3)(vi)	Emergency Contact and Notification Information	Section 1.1
§ 112.7(a)(4)	Procedures and Required Information Regarding a Discharge	Section 1.2
§ 112.7(b)	Fault Analysis	Section 4.1
§ 112.7(c)	Secondary Containment	Section 4.2
§ 112.7(d)	Contingency Planning	Not Used
§ 112.7(e) & § 112.8(c)(6)	Inspections, Tests, and Records	Section 4.3, Appendix C

**Table 1. Plan Elements and Cross Reference to 40 CFR (Part 112) (Continued)**

Section in 40 CFR Part 112	Description of Rule	Section in SPCC Plan
§ 112.7(f)	Employee Training and Discharge Prevention Procedures	Section 5.1
§ 112.7(g)	Security (excluding oil production facilities)	Section 4.5
§ 112.7(h)	Loading/unloading (excluding offshore facilities)	Section 5.2
§ 112.7(i)	Brittle Fracture Evaluation Requirements	Section 4.4
§ 112.7(j)	Conformance with State Requirements	Section 7.0
§ 112.8(b)	Facility Drainage	Section 3.4
§ 112.8(c)	Bulk Storage Containers	Sections 3.3 and 4.2
§ 112.8(d)	Fuel Transfer Operations, Pumping & Facility Process	Section 5.2

### 3.0 GENERAL FACILITY DESCRIPTION (PART 112.7)

The Upper Baker Generation Plant (Facility) is located below the Upper Baker Dam at 47256 Baker Dam Road, 8 miles northeast of Concrete, Washington. The Facility and associated satellite structures are located in Section 31, Township 37 North, Range 9 East and approximately at latitude N 48° 39' 512", longitude W 121° 41' 36". The location of the Facility and associated structures is shown on Figures 1 and 2.

The Facility is a hydro-electrical power generating plant. The generating plant consists of a transformer deck (outside of the plant on the uppermost level), generator level, turbine level, pipe gallery level and sump level. Two 52,400 kW hydro-generator units (Units 1 and 2) and associated electrical transformers and switchgear are located at the generating plant. Other structures at the generating plant include an aboveground storage tank (AST) containing diesel fuel, and a building housing an emergency generator, both on the transformer deck (Figure 3). Other satellite structures located near the Facility include the Fuel Island area, "Beach 3" Spawning area, the Depression Lake Pump Station area and Glover Mountain Communications area (Figure 2).

Oil is stored, used, or handled at the generating plant, the Fuel Island area, Beach 3 Spawning area, the Depression Lake Pump Station area and Glover Mountain Communications area. The location of areas where oil is stored and/or handled is shown on Figures 2 through 5.

To ensure and maintain the Facility's reliability and performance it is visually inspected weekly or more frequently by on-site Turbine Personnel from the Energy Production Department. The Energy Production Department log is kept in the office located at the Lower Baker office, approximately 8 miles south of the Upper Baker Generation Plant (not shown on Figures).

Information provided by PSE indicates that the generating plant and satellite structures were designed and constructed in accordance with the standard of care for engineering and construction practices at the time of their design and with the approval of the respective government agencies and the general public.

### 3.1 COMPLIANCE WITH APPLICABLE SPCC REQUIREMENTS (PARTS 112.7 (A) AND 112.8 (A))

Sections of 40 CFR Part 112.7 that are applicable to this SPCC Plan are Subparts A and B of the rule, and a summary of operations meeting these requirements is as follows. A listing of the criteria applicable to this Facility may be found in Table 1, and detailed information regarding each of these criteria may be found in the report sections described in Table 1.

The Facility is designed to prevent oil releases during operation or maintenance of the Facility. Oil is stored in steel containers that are appropriate for the type of oil being stored in them, and the containers are kept on sufficiently impervious floors with appropriate secondary containment consisting of berms or dikes that will control a release of any stored oil. Figures showing the location of oil-containing equipment (Figures 2 through 5) and a listing of potential releases (Table 4) are presented in the SPCC Plan.

Oil transfers, loading, unloading, and other oil handling activities are manned operations, and transfers are performed at dedicated oil-handling facilities, and/or are performed using drip pans and/or sorbent pads to control any potential spills. Spill kits are located in the generating plant, the Fuel Island area, Beach 3 Spawning area, and the Depression Lake Pump Station area. As part of the oil-handling program, signs

are posted to warn personnel to disconnect hoses and secure containers before transport. Potential spill events at the Facility have been summarized, and a prediction of the volume, rate of flow and direction has been prepared.

Discovery of spills will occur quickly. Oil-containing equipment is routinely inspected, typically on a daily basis. Should a catastrophic failure of a piece of electrical equipment or rotating machinery occur at any time, the loss of generating capacity would immediately affect the distribution system. The operators of the distribution system would be able to quickly direct emergency responders to the site in this event.

Cleanup of minor spills would be performed by Facility personnel, whereas major spills would be controlled and cleaned up by qualified contractors. Contact information is detailed at the beginning of this SPCC Plan, and includes appropriate emergency contacts, including Facility personnel, cleanup contractors, and regulatory agencies, and a description of information required during a release is provided.

Inspections and tests are routinely performed on oil-filled equipment and records of these activities are maintained as part of this SPCC Plan. Visual inspection is performed on all oil-filled equipment, and oil-filled pressure vessels are pressure tested in addition to being visually inspected. Smaller non-pressurized oil containers are visually inspected. Nondestructive testing is not performed on these containers as part of normal industry procedures, and because of the low container stresses associated with the typically small volumes of oil used in these non-pressure applications, visual inspection is adequate to evaluate container condition. No field-fabricated oil containers subject to brittle fracture inspection requirements are used at this Facility. Oil-handling personnel receive training regarding the SPCC Plan on an annual basis.

All areas used for oil storage and handling at this Facility are located inside fenced areas.

### 3.2 LIST OF OIL STORAGE TANKS AND OIL-CONTAINING EQUIPMENT (PART 112.7 (A)(3)(I))

The following oil-containing equipment is present at the Facility:

**Table 2. Non-Electrical Oil-Containing Equipment (55 gallons or larger)**

Oil Storage/Oil-Containing Equipment	Quantity	Total Storage Capacity (gallons)	Contents
<b>Generating Plant</b>			
AST on Transformer Deck	1	100	Diesel
Governor Oil Tanks - Turbine Level	2	1,256	Governor Oil
Turbine Oil Tanks in Oil Storage Room – Turbine Level	2	2,000	New and Used Turbine Oil
Drums/Buckets in Oil Storage Room	10	100-200	Turbine Oil, Hydraulic Oil, Grease, Solvent, Cutting Oil



**Table 2. Non-Electrical Oil-Containing Equipment (55 gallons or larger) (Continued)**

Oil Storage/Oil-Containing Equipment	Quantity	Total Storage Capacity (gallons)	Contents
<b>Fuel Island Area</b>			
USTs	2	2,000	Gasoline and Diesel
AST	1	1,000	Diesel
Portable Gasoline Tanks in Hazardous Materials Storage Trailer	25	Approximately 50	Gasoline
<b>Depression Lake Pump Station Area</b>			
Actuator/Butterfly Valve System	1	130	"Clarity 48" Hydraulic Oil
<b>Glover Mountain Telecom. Area</b>			
Fuel Tank on Generator	1	100	Diesel
<b>"Beach 3" Spawning Area</b>			
AST	1	250	Diesel

Storage Subtotal:

Aboveground Non-Electrical Oil-Containing Equipment: 5,116 gallons

Below ground Non-Electrical Oil-Containing Equipment: 2,000 gallons

The location of this equipment is shown on Figures 2 through 5.

**Table 3. Oil-Containing Electrical Equipment (55 gallons or larger)**

Oil Storage/Oil Containing Equipment	Quantity	Total Storage Capacity (gallons)	Contents
<b>Generating Plant</b>			
Step-up Transformers on deck	4 (three energized, one spare)	13,900	Mineral Oil
Turbine bearings, thrust and guide	2	2,000	Turbine oil
<b>Depression Lake Pump Station Area</b>			
1,000 KVA Transformers	3	1,035	Mineral Oil

Storage Subtotal: Oil-Containing Electrical Equipment: 17,070 gallons

**Total Facility Oil Storage:** 24,286 gallons

The location of this equipment is shown on Figures 2 through 5.

### **3.3 DESCRIPTION OF OIL STORAGE AND OIL-CONTAINING EQUIPMENT (PART 112.7 (A)(3))**

#### **3.3.1 Generating Plant**

##### **3.3.1.1 Aboveground Storage Tank**

One 100-gallon double-walled factory fabricated steel AST is located outside on the transformer deck at the generating plant. The tank supplies diesel via aboveground piping to a generator also on the transformer deck. The location of the tank and other oil-containing structures at the generating plant are shown on Figure 3.

##### **3.3.1.2 Governor Oil Tanks**

Two 628-gallon factory fabricated governor oil tanks are located on the turbine level of the generating plant. The tanks are single-walled pressure vessels that contain governor oil.

##### **3.3.1.3 Turbine Oil Tanks**

Two 1,000-gallon factory fabricated turbine oil tanks are located in the oil storage room on the turbine level of the generating plant. One tank contains new turbine oil and the other tank contains used turbine oil. The tanks are single-walled steel ASTs. These tanks are only used during generator unit rebuilds, which seldom occur (average every 15 to 30 years).

##### **3.3.1.4 Miscellaneous Oil Storage**

Typically, two 55-gallon drums containing hydraulic oil and turbine oil are stored on a spill pallet in the oil storage room. Four 5-gallon buckets containing hydraulic oil, grease, cutting oil and solvent and two 15-gallon drums of grease are also located in the oil storage room. Other containers of petroleum-based lubricants may be stored on spill pallets in this area.

##### **3.3.1.5 Step-Up Transformers**

Four step-up transformers are located east of the powerhouse on the transformer deck. The easternmost transformer is a spare transformer and is not in use. Each transformer contains 3,475 gallons of mineral oil. The locations of the transformers are shown on Figure 3.

##### **3.3.1.6 Grounding Transformers**

Two turbine grounding transformers are located on the turbine level of the generating plant, one transformer connected to each unit. Each grounding transformer contains 20 gallons of mineral oil.

#### **3.3.2 Fuel Island Area**

The locations of the following equipment are indicated on Figure 4.

##### **3.3.2.1 Underground Storage Tanks**

Two 1,000-gallon underground storage tanks (USTs) containing diesel and gasoline are located underneath a fueling station at the Fuel Island area. The tanks are of double-walled fiberglass construction, with an interstitial leak-detection system designed with an audible alarm in the event of an inner or outer wall breach. The USTs are regulated separately from this SPCC Plan.

##### **3.3.2.2 Aboveground Storage Tanks**

A 1,000-gallon diesel AST is located west of the Hazardous Materials Storage Trailer. The tank is a double-walled AST with a leak detection system similar to that of the USTs.

### **3.3.2.3 Hazardous Materials Storage Trailer**

Approximately 25 portable gasoline tanks, ranging in size from 1 to 6 gallons, are located in the hazardous material storage trailer at the Fuel Island area. The trailer is a factory-fabricated steel trailer built by McKinney Trailer in Seattle, Washington, and is designed with secondary containment integral to the trailer body.

### **3.3.3 Depression Lake Pump Station Area**

The location of the following equipment is indicated on Figure 5.

#### **3.3.3.1 Actuator/Butterfly Valve System**

A single actuator/butterfly valve system, containing approximately 130 gallons of “Clarity 48” hydraulic oil, is located on the pump station.

#### **3.3.3.2 1,000 kVA Transformers**

Three 1,000 kVA transformers, each containing 345 gallons of transformer oil, are located in the switchyard at the Pump Station Area.

### **3.3.4 Glover Mountain Telecommunications Area**

#### **3.3.4.1 Diesel Generator**

A diesel generator with an attached 100-gallon steel fuel tank is located at the Glover Mountain Telecommunications area.

#### **3.3.5 “Beach 3” Spawning Area**

A diesel generator with an attached 250-gallon diesel AST is located at the Beach 3 Spawning area.

## **3.4 DRAINAGE PATHWAYS AND DISTANCE TO NAVIGABLE WATERS (PART 112.8(B))**

### **3.4.1 On-Site Drainage**

#### **3.4.1.1 Generating Plant**

Oil spills on the transformer deck, generator level, turbine level or pipe gallery level all eventually flow to the sump level of the generating plant via drains and pipes. See Section 4.2 for a discussion of transformer deck drainage. The sump has a capacity of 2,660 gallons and is equipped with an oil skimmer and a floating oil detection sensor. The skimmer system continuously removes any oily sheen that may be present in the sump, and collects the oil in a 55-gallon drum next to the sump. The sump pumps water to the dam tailrace. The sump is also visually inspected for oil twice daily by the Facility operators.

The sensor continuously monitors the sump and sounds an alarm if the oil level is 1/4-inch thick or more. The sensor alarm also pages the operator in the event oil is detected in the sump.

The sump pumps stop pumping when the water elevation is approximately 2.75 feet above the floor of the sump, so any accumulation of oil in the sump from a spill would likely trigger an alarm before oil is drawn into the pump system. In the event of a spill, the oil detection system will page the operator, who

will respond within a 30-minute timeframe. The operator may then manually control the pumps from the sump room with the pump starting controls on the pump start boxes

#### **3.4.1.2 Fuel Island Area**

The Fuel Island area does not have an on-site drainage system. Surface drainage is to the east as described in Section 3.4.2.

#### **3.4.1.3 Depression Lake Pump Station Area**

Three 1,000 kVA transformers are located within a curbed concrete containment area at the Depression Lake Pump Station area. The concrete containment area drains to a vault located approximately 10 feet northwest of the containment area. The vault is equipped with an oil-stop valve, allowing rainwater to drain to Depression Lake, but automatically closing in the event of an oil spill. Depression Lake is approximately 50 feet north of the vault.

#### **3.4.1.4 Glover Mountain Telecommunications Area**

The Glover Mountain Telecommunications area does not have an on-site drainage system. Surface drainage is to the north, as described in Section 3.4.2.

#### **3.4.1.5 Beach 3 Spawning Area**

The Beach 3 Spawning area does not have an on-site drainage system. Surface drainage is to the north as described in Section 3.4.2.

### **3.4.2 Potential Off-Site Drainage Pathways**

#### **3.4.2.1 Generating Plant**

Potential off-site spills at the generating plant would flow west to the dam tailrace water adjacent to the dam.

#### **3.4.2.2 Fuel Island Area**

Potential spills at the Fuel Island area would flow east approximately 110 feet to an unlined ditch, which then would flow approximately 400 feet south to the dam tailrace.

#### **3.4.2.3 Depression Lake Pump Station Area**

Three transformers and a capacitor are located off the northeast and southwest ends of the concrete containment area at the Depression Lake Pump Station area. Potential spills from the transformers or capacitor would flow northwest as overland flow approximately 50 feet to Depression Lake.

The actuator/butterfly valve system and pump bearing systems at the Depression Lake Pump Station are located over/in a vault. Potential spills from the actuator or bearing systems would be contained on the surface of the water in the vault, as the pump low-level is set to keep the water level in the vault above the bottom of the “trash racks” of the vault.

#### **3.4.2.4 Glover Mountain Telecommunications Area**

Potential spills from the diesel generator at the Glover Mountain Telecommunications area would flow as overland flow toward Depression Lake, approximately 1,600 feet north.

#### **3.4.2.5 "Beach 3" Spawning Area**

Potential spills from the AST or diesel generator at the Beach 3 Spawning area would flow north as overland flow approximately 100 feet towards Channel Creek and into Baker Lake.

#### 4.0 POTENTIAL SPILLS AND PREVENTION MEASURES

##### 4.1 FAULT ANALYSIS – POTENTIAL SPILL EVENTS (PART 112.7(B))

The probability of a major uncontrolled oil spill at the Facility or associated satellite structures is low. Although oil storage tanks and several single pieces of electrical equipment contain large quantities of oil, the containment systems at the Facility and associated structures are designed to contain potential spills. Any significant oil spill probably would be caused by a major structural failure. More likely potential spill events would be:

- A slow leak from a piece of stored equipment due to a failed gasket or seal, cracked bushing, or a leaking oil stop plug, fitting, valve or similar item. An event of this nature would be readily detectable during routine inspection or day-to-day activities, and allow ample response time for containment.
- A spill of oil during repair or maintenance of equipment on site. An event of this nature would be quickly detected by the personnel performing the repair or maintenance, and response would be rapid.

Potential spill events at the Facility are summarized in Table 4.

**Table 4. Potential Spill Events (Part 112.7(B))**

Source	Type of Failure	Volume (gallons)	Maximum Rate (gallon/hr)	Direction of Flow	Containment
<b>Generating Plant</b>					
AST on Transformer Deck	Rupture; leakage	100	100	none	Concrete containment
Governor Oil Tanks – Turbine Level	Rupture; leakage	628	628	Towards Sump	Sump
Turbine Oil Tanks in Oil Storage Room – Turbine Level		1,000	1,000	Towards Sump	670-gallon containment /then to sump
Drums/Buckets in Oil Storage Room	Rupture; leakage	55	55	None	670-gallon containment /then to sump
Transformers on deck	Rupture; leakage	13,900	13,900	Towards Sump	Containment Vault then to sump
<b>Fuel Island Area</b>					
AST	Rupture; leakage	1,000	1,000	East to ditch	To be replaced with double-walled AST with leak detection



**Table 4. Potential Spill Events (Part 112.7(B)) (Continued)**

Source	Type of Failure	Volume (gallons)	Maximum Rate (gallon/hr)	Direction of Flow	Containment
<b>Depression Lake Pump Station Area</b>					
Pump Bearing Systems	Rupture; leakage	60	60	Into Depression Lake	Vault
Actuator/Butterfly Valve System	Rupture; leakage	130	130	Into Depression Lake	Vault
1,000 kVA Transformers	Rupture; leakage	345	345	Into Vault	Vault
<b>Glover Mountain Telecom Area</b>					
Fuel tank	Rupture; leakage	100	100	West	None
<b>“Beach 3” Spawning Area</b>					
AST	Rupture; leakage	250	250	North	Fiberglassed Box

## 4.2 OIL SPILL CONTAINMENT SYSTEMS (PART 112.7(C))

Containment systems for each building and oil storage structure are described in this section.

### 4.2.1 Generating Plant

The generating plant is a concrete structure at the base of the Upper Baker Dam, which consists of – from top level to bottom – the transformer deck (outside), the generator level, turbine level, pipe gallery level and the sump level (all inside).

#### 4.2.1.1 Transformer Deck

Three step-up transformers and a spare step-up transformer, each containing 3,475 gallons of oil, are located on the transformer deck between the generating plant and dam wall. A collection area is located below the three transformers that are in service, and a 6-inch concrete berm around the spare transformer directs flows from around the spare transformer into the collection area. The collection area is filled with washed rock and its containment capacity is negligible. The collection area drains to a trapezoid-shaped containment vault located just below and to the west of the collection area.

The capacity of the vault is approximately 21,600 gallons (155 percent of the total volume of the four step-up transformers combined). The vault drains via enclosed pipe to the sump, and an automatic shutoff valve is located between the vault and sump. The valve closes in the event of a fire or a low-level alarm in the transformers.

The sump has a capacity of approximately 2,660 gallons and drains to the dam tailrace water. The sump is equipped with a floating oil detection sensor. The sensor continuously monitors the sump and sounds an alarm if the oil level is 1/4-inch thick or more. The sensor alarm also pages the operator in the event oil is detected in the sump.

The sump pumps stop pumping when the water elevation is approximately 2.75 feet above the floor of the sump, so any accumulation of oil in the sump from a spill would likely trigger an alarm before oil is drawn into the pump system. In the event of a spill, the oil detection system will page the operator, who will respond within a 30-minute timeframe. The operator may then manually control the pumps from the sump room with the pump starting controls on the pump start boxes.

#### **4.2.1.2 Generator Level**

Oil spills from equipment on the generator level would flow to the sump level. The sump has a capacity of 2,660 gallons, which is adequate to contain a spill from any individual piece of equipment on the generator level.

#### **4.2.1.3 Turbine Level**

The oil storage room is located on the turbine level. The oil storage room measures approximately 10 feet by 21 feet, and contains a 5-inch-high berm at the door, for a total secondary containment capacity of 670 gallons. Drums and buckets in the oil storage room are kept on secondary spill containment pallets. A drain in the floor of the oil storage room has been permanently plugged with an expandable rubber plug.

The turbine bearing oil tanks in the oil storage room are each 1,000-gallon-sized tanks, and would overflow the oil storage room containment berm. These and any other spills on the turbine level would flow to the sump level at the generating plant. The sump has 2,660 gallons of containment capacity, which is adequate to contain a spill from any individual piece of equipment on the turbine level.

#### **4.2.1.4 Pipe Gallery**

Oil spills on the pipe gallery would flow to the sump level. The sump has 2,660 gallons of containment capacity, which is adequate to contain a spill from any individual piece of equipment on the pipe gallery level.

### **4.2.2 Fuel Island Area**

The 1,000-gallon AST at the Fuel Island area is currently housed in temporary secondary containment consisting of a flexible plastic liner that passes underneath the tank and is affixed to the tops of ecology blocks surrounding the tank. Rainwater from the temporary containment is discharged by a 12-volt submersible pump after being checked for oil. The tank is to be replaced with a double-walled 1,000-gallon AST with electronic leak detection in 2006.

The portable gasoline cans are housed in the Hazardous Materials Storage Shed, which is a steel trailer designed as secondary containment.

### **4.2.3 Depression Lake Pump Station Area**

The three 1,000 kVA transformers at the Depression Lake Pump Station area are located on a curbed concrete pad with a capacity of 1,480 gallons, or 143 percent of the total volume of the transformers. The concrete containment area drains to a vault located approximately 10 feet northwest of the containment area. An oil stop valve allows rainwater to drain out of the vault, but closes automatically in the event of an oil release. The vault is routinely inspected for oil. The vault drains to Depression Lake, approximately 50 feet to the north.

#### **4.2.4 Glover Mountain Telecommunications Area**

The diesel generator at the Glover Mountain Telecommunications area includes a double-walled 100-gallon fuel tank. The generator sits on a non-curbed concrete pad. Drainage off the pad would be north toward Depression Lake.

#### **4.2.5 "Beach 3" Spawning Area**

Both the 250-gallon diesel tank and generator at the Beach 3 Spawning area are housed in secondary containment. The fuel tank is contained in a fiberglassed wood box that has a capacity of 300 gallons (120 percent of the capacity of the fuel tank). The pump is housed in a plastic "collapse-a-tainer" spill containment system. The capacity of the container is 440 gallons, which is significantly greater than the possible oil or diesel capacity of the generator.

### **4.3 INSPECTIONS AND RECORD KEEPING (PART 112.7 (E))**

Inspections of lubrication systems, electrical equipment, and oil storage systems are performed on a regular basis, typically daily when personnel are present. Inspection procedure, any required physical testing of oil-containing equipment and record keeping requirements for oil-containing equipment and stored oil are described in the following subsections.

#### **4.3.1 Oil Filled Electrical Equipment**

Oil-filled electrical equipment at the Facility is visually inspected on a weekly basis or more often by Facility personnel for overall condition to include any leaks, damage, or other conditions that could potentially contribute to a release. Inspected equipment includes the following:

- Four transformers on deck at the generating plant
- Two grounding transformers at the generating plant
- Six transformers at the Depression Lake Pump Station area
- Capacitor at the Depression Lake Pump Station area
- Pump butterfly valve/actuator at the Depression Lake Pump Station area

Areas to be inspected include the sides and bottoms of the equipment, and any bushings or plugs on the equipment. These areas are evaluated to see if oil is present, and oil levels are checked using the sight glass in the equipment. Mountings, supports, brackets and bases for oil-filled equipment will be inspected for any damage, deterioration, corrosion or other evidence of potential failure. Any damage or deterioration of the mounting system will be reported to the Maintenance Supervisor for the Facility, and repaired or replaced as necessary.

Any leakage from electrical equipment is noted, and cleaned up with absorbent pads as necessary. These losses and any oil added to the electrical equipment are recorded on a PSE Weekly Facility Inspection Form (Form 1185) or an equivalent form developed by the Facility to evaluate if oil may be leaking from the electrical equipment at some unseen location.

Visual inspection of the oil-filled electrical equipment is the only means of inspection performed on this type of equipment. The equipment is non-pressurized, and other means of testing of the physical integrity of electrical equipment housings are not industry practice. It is our opinion that visual inspection of this equipment is adequate to evaluate its condition.

Any other maintenance and inspection activities will be documented using a PSE Weekly Facility Inspection Form (Form 1185) or an equivalent form developed by the Facility. Copies of the completed inspection form are maintained for a period of 5 years in Appendix C of this SPCC Plan.

#### **4.3.2 Turbine Bearing System, Thrust and Guide at Generating Plant**

The turbine bearing system in the generating plant is visually inspected on a regular basis, typically daily, by Facility personnel for leaks and oil levels. Areas to be inspected are piping, piping connections, bearing housings, shaft seals, gasketed joints in oil-filled equipment, lubrication oil pressure vessels and any other oil-filled equipment connected to the turbine lubrication system. Mountings, supports, brackets and bases for oil-filled equipment will be inspected for any damage, deterioration, corrosion or other evidence of potential failure. Any damage or deterioration of the mounting system will be reported to the Maintenance Supervisor for the Facility, and repaired or replaced as necessary.

Any leakage from the system is noted, and cleaned up with absorbent pads as necessary. These losses and any oil added to the system are recorded on a PSE Weekly Facility Inspection Form (Form 1185) or an equivalent form developed by the Facility to evaluate if oil may be leaking from the turbine lubrication system at some unseen location. Oil is periodically changed from the system, and oil changes are also documented on an inspection form. Copies of these completed inspection forms are maintained in Appendix C of this SPCC Plan.

The sump at the lower level of the generating plant includes an oil skimmer system, as well as a floating oil detection sensor. The oil skimmer system continuously removes any oily sheen that may be present in the sump, and collects the oil in a 55-gallon drum next to the sump.

The sump is equipped with a floating oil detection sensor. The sensor continuously monitors the sump and sounds an alarm if the oil level is 1/4-inch thick or more. The sensor alarm also pages the operator in the event oil is detected in the sump.

The sump pumps stop pumping when the water elevation is approximately 2.75 feet above the floor of the sump, so any accumulation of oil in the sump from a spill would likely trigger an alarm before oil is drawn into the pump system. In the event of a spill, the oil detection system will page the operator, who will respond within a 30-minute timeframe. The operator may then manually control the pumps from the sump room with the pump starting controls on the pump start boxes.

Pressure vessels that hold reserve oil in the turbine system are pressure tested every 10 years in accordance with American Petroleum Institute (API) 572 to evaluate their suitability for use. Records of this testing provided by the subcontractor performing the testing will be maintained in Appendix C of this SPCC Plan. Pressure testing of the remainder of the lubrication system would likely damage seals and gaskets in the system, and other methods of non-destructive testing would reveal little more information that could be discovered using visual inspection procedures. It is our opinion that visual inspections of the balance of the lubrication system are adequate to evaluate its condition.

Any other maintenance and inspection activities will be documented using a PSE Weekly Facility Inspection Form (Form 1185) or an equivalent form developed by the Facility. Copies of the completed inspection form are maintained for a period of 5 years in Appendix C of this SPCC Plan.

#### **4.3.3 Pump Bearing Systems at Depression Lake Pump Station Area**

The pump bearing systems at the Depression Lake Pump Station area are visually inspected on a regular basis, typically daily, by Facility personnel for leaks and oil levels. Areas to be inspected are piping, piping connections, bearing housings, shaft seals, gasketed joints in oil filled equipment, lubrication oil pressure vessels and any other oil filled equipment connected to the pump lubrication systems. Mountings, supports, brackets and bases for oil-filled equipment will be inspected for any damage, deterioration, corrosion or other evidence of potential failure. Any damage or deterioration of the mounting system will be reported to the Maintenance Supervisor for the Facility, and repaired or replaced as necessary.

Any leakage from the system is noted, and cleaned up with absorbent pads as necessary. These losses and any oil added to the system are recorded on a PSE Weekly Facility Inspection Form (Form 1185) or an equivalent form developed by the Facility to evaluate if oil may be leaking from the turbine lubrication system at some unseen location. Oil is periodically changed from the system, and oil changes are also documented on an inspection form. Copies of these completed inspection forms are maintained in Appendix C of this SPCC Plan.

#### **4.3.4 Aboveground Storage Tanks**

Visual inspections of ASTs are conducted frequently, typically daily, to check for leaks, damage, corrosion or any other conditions that could result in an uncontrolled release of oil. This inspection is documented using a PSE Weekly Facility Inspection Form (Form 1185) or an equivalent form developed by the Facility. Copies of the completed inspection records are kept at the Lower Baker office, approximately 8 miles south of the Upper Baker Generating Plant (not shown on Figures).

##### **4.3.4.1 Generating Plant**

The following tanks are inspected at the generating plant:

- Two 1,000-gallon new and used turbine oil tanks in the oil storage room on the turbine level
- Two 628-gallon governor oil tanks on the turbine level
- One 100-gallon diesel oil tank on the transformer deck

##### **4.3.4.2 Fuel Island Area**

The Fuel Island area contains one 1,000-gallon diesel AST that is inspected as described at the beginning of this section. The 250-gallon AST at the Fuel Island area is no longer used for oil storage.

##### **4.3.4.3 “Beach 3” Spawning Area**

The 250-gallon AST at the Beach 3 Spawning area is inspected as described in Section 4.3.4.



#### **4.3.5 Miscellaneous Oil Storage Areas**

Other stored oil and oil-filled equipment at the generating plant or satellite locations is inspected frequently by Facility personnel for overall condition to include any leaks, damage, or other conditions that could potentially contribute to a release.

Visual inspections are performed on stored oil drums, containers, and other oil filled equipment. Areas inspected include the sides and bottoms of the containers, and any drains, fittings or seams in the containers or equipment. If leaks, corrosion dents, or other indications of potential leakage are observed, appropriate action will be taken. Leaking containers will be plugged and/or placed on secondary containment. Containers that have conditions indicative of potential leakage will be placed on secondary containment, and replaced as soon as possible. Any oil will be cleaned up using the procedures described in PSE Standard 0150.3100, "Cleanup of Oil Spills."

Visual inspection of these types of oil-filled containers (drums and similar non-pressure containers) equipment is the only means of inspection performed on this type of equipment. The equipment is non-pressurized, and other means of testing of the physical integrity of these types of containers are not industry practice. It is our opinion that visual inspection of this equipment is adequate to evaluate its condition.

Inspections are documented using a PSE Weekly Facility Inspection Form (Form 1185) or an equivalent form developed by the Facility. Copies of the completed inspection form are maintained for a period of 5 years in Appendix C of this SPCC Plan.

#### **4.4 BRITTLE FRACTURE EVALUATION REQUIREMENTS (PART 112.7 (I))**

The Facility does not use any field constructed aboveground containers. All electrical devices and oil containers used at the Facility are commercially made in a factory environment and are not subject to evaluation for failure by brittle fracture. Should any electrical device or oil container appear to be developing fractures or cracking in its metal case, the device or container will be immediately removed from service.

#### **4.5 SECURITY (PART 112.7 (G))**

The Facility is manned 8 hours a day – Monday through Friday, and the operator is within 15 minutes of the plant 24 hours per day, seven days per week.

Measures taken to prevent trespassing, vandalism, and sabotage include, but are not limited to, the following:

- Security fences or water surrounding the Facility site.
- Building and yard lights.
- Warning devices: "Danger" and "No Trespassing" signs.
- Locks on gates and buildings after hours.
- Pump shutoff switches located near the fueling station to shut off pumps in the event of a spill.

## 5.0 TRAINING AND DISCHARGE PREVENTION PROCEDURES

### 5.1 TRAINING (PART 112.7 (F))

The Hydro Services Manager or an individual designated by the Hydro Services Manager are responsible for providing an annual training program for Facility personnel regarding SPCC measures.

Spill prevention training will be provided on an annual basis to all personnel that are involved in handling oil. The training program includes the information included in this Plan, methods and procedures used to prevent, control, and clean up an oil spill and a review of pollution control regulations. Training will also include describing any known releases or failures at the Facility, lessons learned from these events, updates on Facility equipment and new precautions to be observed. The following PSE Standards found in Appendix B shall be included as a part of the training:

- 0150.3100, "Cleanup of Oil Spills"
- 0150.3150, "Oil Sampling Procedures for Distribution Transformers and Oil-Filled Equipment"

Other PSE Standards and Specifications also may be included as part of the training. A record of additional standards that are used for training will be maintained in Appendix C.

The examples shown in the Standards are general ways of containing an oil spill. The exact methods employed will depend on local conditions and circumstances. All referenced standards or specifications are attached to this Plan.

Training programs and periodic briefings include review of this Plan and describe actual experiences, recent spill events or failures, and new preventive control and cleanup measures. The individual responsible for training shall maintain a copy of the training roster in Appendix C of this Plan. A sample training roster is included in Appendix B.

### 5.2 OIL LOADING AND HANDLING PROCEDURES (PART 112.7 (A)(3)(III), PART 112.7(H) AND PART 112.8(D))

It is stressed to all personnel that an essential part of oil spill prevention is being alert for signs of leaks and the prevention of spills during their daily activities. This is accomplished by being observant and by performing regular inspections at the Facility. These inspection procedures, as required by 40 CFR Part 112.8(d)(4) are described in detail in Section 4.3. Leaks or spills shall be immediately reported in accordance with Section 1.1 and the Section 6.1.2 of this document, and appropriate response activities shall be started immediately.

#### 5.2.1 Transferring Fuel or Oil

Tank truck offloading occurs adjacent to the USTs at the Fuel Island area and on the dam structure at the generating plant parking level using a remote fill ports for the oil tanks. No containment has been provided for offloading. Tank truck offloading procedures meet the minimum requirements and regulations of the Washington State Department of Transportation. Truck drivers observe the tank throughout offloading procedures, and drains and outlets on tank trucks are checked for leakage before offloading or departure.

### **5.2.2 Handling Oil-Filled Equipment**

Spill kits will be readily available when handling oil drums and oil-filled equipment. Drums or oil-filled equipment will be sealed, checked for leaks, and if necessary, re-sealed or tightened. Containers or equipment will be properly secured before they are loaded and moved.

## **5.3 SIGNS, PLANS AND OIL CONTAINMENT KITS**

### **5.3.1 Oil Spill Notification, Sign, and Plan Location**

Signs as described in PSE Specification 1275.8100, "In Case of Oil Spill" are be posted along the inside of perimeter fences and in any oil storage or distribution area, and emergency spill contact stickers have been placed on all vehicles at the Facility. Copies of relevant standards are attached to this Plan. The SPCC Plan shall be kept in the following locations:

- The Lower Baker office
- The generating plant
- The Plan originals are kept on file in the Environmental Services Department

### **5.3.2 Oil Spill Containment Kits**

Oil spill equipment and materials are stored in "Small Oil Spill Kits," which are stored at various locations throughout the Facility. Kits shall be readily accessible and shall not be hidden or covered with other materials or used for anything other than their intended purpose.

Additional kits and materials are available through General Stores.

## **6.0 SPILL EVENT: CONTAINMENT AND COUNTERMEASURE PROCEDURES (PART 112.7 (A)(3)(III) AND (IV))**

### **6.1 GENERAL PROCEDURES**

Containment and countermeasure actions must start immediately after a spill is discovered. The primary objective will be to contain spilled oil within the immediate area, and prevent its entry into the Facility drainage system, the public drainage system or the navigable waters of the United States. This objective shall be met while maintaining proper health and safety procedures. General procedures to be followed in any and all cases of an oil spill event are described below.

#### **6.1.1 Identification**

Upon discovery of a spill during normal operations or as a result of an alarm at the Facility, the discoverer shall immediately evaluate whether the spill can be approached safely. From a safe distance, the discoverer shall evaluate the nature and extent of the spill. If possible and safe, the discoverer shall identify the source and stop the leak. The discoverer then shall initiate immediate action to contain the spill, and shall make the notifications described in Section 1.1 or the following section.

#### **6.1.2 Notification and Emergency Contacts**

The following notifications shall be made upon discovery of a spill:

- Notify the 24-hour spill response coordinator number (206) 994-3186.
- Notify the Maintenance Supervisor, Upper Baker Operator or designee – phone numbers for the maintenance supervisor are (360) 853-8341, (internal) PSE extension at 86-3042 or cell (360) 853-8608. Phone numbers for the Upper Baker Operator are (360) 853-8608 or internal PSE extension at 86-2033.
- The local fire department shall be notified by the plant operator or designee if there is a potential fire hazard (Phone 911 [external] or 9-911 [internal]).
- The spill response coordinator will advise on procedures for handling the spill. Generally, the spill response coordinator or a spill contractor will respond if a spill meets the following criteria:
  - The spill is greater than 5 gallons;
  - The spill enters the Facility drainage system;
  - The spill is from PCB-containing equipment and affects underlying earth, asphalt or concrete; or
  - The spill flows off PSE property.
- The spill response coordinator shall contact the appropriate State and Federal agencies as required. The spill response coordinator or Environmental Services shall be the only contact with State and Federal agencies.

#### **6.1.3 Containment**

Personnel from the Facility and the cleanup contractor will use the following general actions and PSE guidelines for spill control and containment. Facility personnel will use available spill kits and equipment

stored at the Facility. The spill response coordinator will bring material and equipment as required to control and/or contain the spill. This equipment may be limited to hand tools and sorbent media for any spill that may be reasonably anticipated to occur at this Facility. The spill coordinator or contractors have other equipment available, up to and including heavy earthmoving equipment and watercraft capable of recovering spills from waterways in the event of a catastrophic failure at the Facility.

- Confine and prevent any further spread of the oil (see PSE Standard 0150.3100).
- Plug nearby storm drains. Block catch basins by putting plastic sheeting under the catch basin grates and/or by building diversion dikes of absorbent or other material around the catch basin.
- Reduce or eliminate the spread of oil by using drain system isolation valves, dikes, channels, dams and/or oil absorbent material (see PSE Standard 0150.3100).
- Stop the oil leak at its source, for example:
  - Plug the leak with available material;
  - If a transformer or other piece of equipment is leaking, it may be possible to turn it on its side or upside down to raise the point that is leaking; or
  - If rupture or leak cannot be plugged, use bins, pans, barrels, or containers to catch the oil if possible.

After the spill has been contained, the spill response coordinator will coordinate cleanup of the material.

## **6.2 CLEANUP AND PCB SPECIAL HANDLING PROCEDURES (PART 112.7 (A)(3)(V))**

A representative of the spill coordinator shall coordinate the collection of spilled oil and removal of contaminated soils and other materials. Spilled oil and contaminated media will be transported to PSE's South King County Waste Management Facility as generally described in Standard 0150.3100. Disposal of spilled oil and contaminated materials shall be arranged at the South King County Waste Management Facility, which is a licensed moderate-risk waste facility (King County Permit Number PR0064285, RCRA ID WAD000006569). Recovered oil, contaminated soil or contaminated water will be disposed of by recycling, thermal treatment and/or land filling at permitted facilities as appropriate.

Special handling is required for a spill event originating from containers or electrical items that are labeled as containing PCB or PCB-contaminated oil. The label used for identifying such containers and items is shown in Standard 0150.3125; cleanup is outlined in Standard 0150.3100 "Cleanup of Oil Spills." Any oil-filled device of unknown PCB content must be assumed to be PCB contaminated and handled as such. The spill contractor shall be notified when the earth, concrete or asphalt under a leaking PCB-containing device has been contaminated. The spill contractor will verify for adequacy of cleanup.

## **6.3 ASSESSING THE SPILL EVENT**

In accordance with Section 6.1.2, the spill response coordinator shall be notified of the spill event. A spill response contractor shall perform any environmental sampling necessary to evaluate areas affected by the spilled oil, assess and quantify the potential environmental damage, and collect necessary information that may include soil and water samples to confirm that the extent of spilled material has been identified and spilled material has been cleaned up.

Puget Sound Energy  
Upper Baker Generation Plant  
47256 Baker Dam Road  
Concrete, Washington 98237

## **6.4 REPORT REQUIREMENTS**

### **6.4.1 Form**

Report oil spills using the “Oil Spill Report” form (PSE Form 1184).

### **6.4.2 Notification**

A copy of the Oil Spill Report, including the test results and a map identifying the spill location if prepared, must be forwarded to the Environmental Services Department in a timely fashion. Environmental Services will manage the required State and Federal spill notification and follow-up requirements.

## **7.0 CONFORMANCE WITH STATE REQUIREMENTS (PART 112.7 (J))**

Oil spills in the State of Washington are regulated under the Revised Code of Washington (RCW), Chapters 90.48 and 90.56, which are enforced by the Washington State Department of Ecology (Ecology). RCW 90.48.080 prohibits the discharge of polluting materials into the waters of the State, and RCW 90.56 describes the spill prevention and cleanup process. There is no *de minimus* release amount defined in these regulations. Rather, any amount of oil that degrades the waters the State constitutes a release. Ecology typically considers the creation of a visible sheen on the water as a spill.

The goal of this Plan is consistent with the objective of RCW 90.48.080, and the items presented in this Plan, including prevention planning, Facility design and operation, spill response and spill notification requirements are in general conformance with the requirements of RCW 90.56. The conformance of the Facility with the requirements of 40 CFR Part 112 as discussed in Section 3.1 of this document addresses the requirements of RCW 90.56.



## 8.0 PLAN AMENDMENT BY THE REGIONAL ADMINISTRATOR (PART 112.4)

One spill event reportable under Washington State law occurred at the Facility in the past five years. Approximately 20 gallons of diesel fuel and motor oil were released from a diesel-powered water pump at the “Old Spawning Beach” on September 25, 2002. The Old Spawning Beach is located approximately 1,000 feet northwest of the “Beach 3” Spawning Area.

The fuel and oil impacted vegetation and stream banks near the Old Spawning Beach along Channel Creek. The spill was reported to Ecology on the same day the spill occurred (Ecology incident number 529267). Approximately 50 cubic yards of impacted soil and vegetation were removed from the site and disposed of at CSR Associated in Everett, Washington. Chemical analytical results of five confirmation soil samples taken from the limits of the excavation indicated diesel- and lube oil-range hydrocarbons were either not detected or detected at concentrations less than MTCA Method A cleanup levels. In the event of a spill resulting in discharges of more than 1,000 gallons of oil in a single discharge, or more than 42 gallons of oil in each of two discharges occurring in a single year, the following information must be submitted to the EPA Regional Administrator and Ecology for their review within 60 days from the time of such a release or releases(s):

1. Name of the facility;
2. Your name;
3. Location of the facility;
4. Maximum storage or handling capacity of the facility and normal daily throughput;
5. Corrective action and countermeasures you have taken, including a description of equipment repairs and replacements;
6. An adequate description of the facility, including maps, flow diagrams, and topographical maps, as necessary;
7. The cause of discharge, including a failure analysis of the system or subsystem in which the failure occurred;
8. Additional preventive measures you have taken or contemplated to minimize the possibility of recurrence; and
9. Such other information as the Regional Administrator and State Department of Ecology may reasonably require pertinent to the Plan or discharge.

The Plan will be amended, if required after review of the information submitted above by the EPA Regional Administrator or Ecology. The Regional Administrator may require that the Plan be amended if he finds that it does not meet the requirements of this part or that amendment is necessary to prevent and contain discharges from the facility.



Map Revised: June 06, 2005

Path: 0:\186634\00\GIS\018663400\_T6\_UB\_FIG-1.mxd

Office: TAC

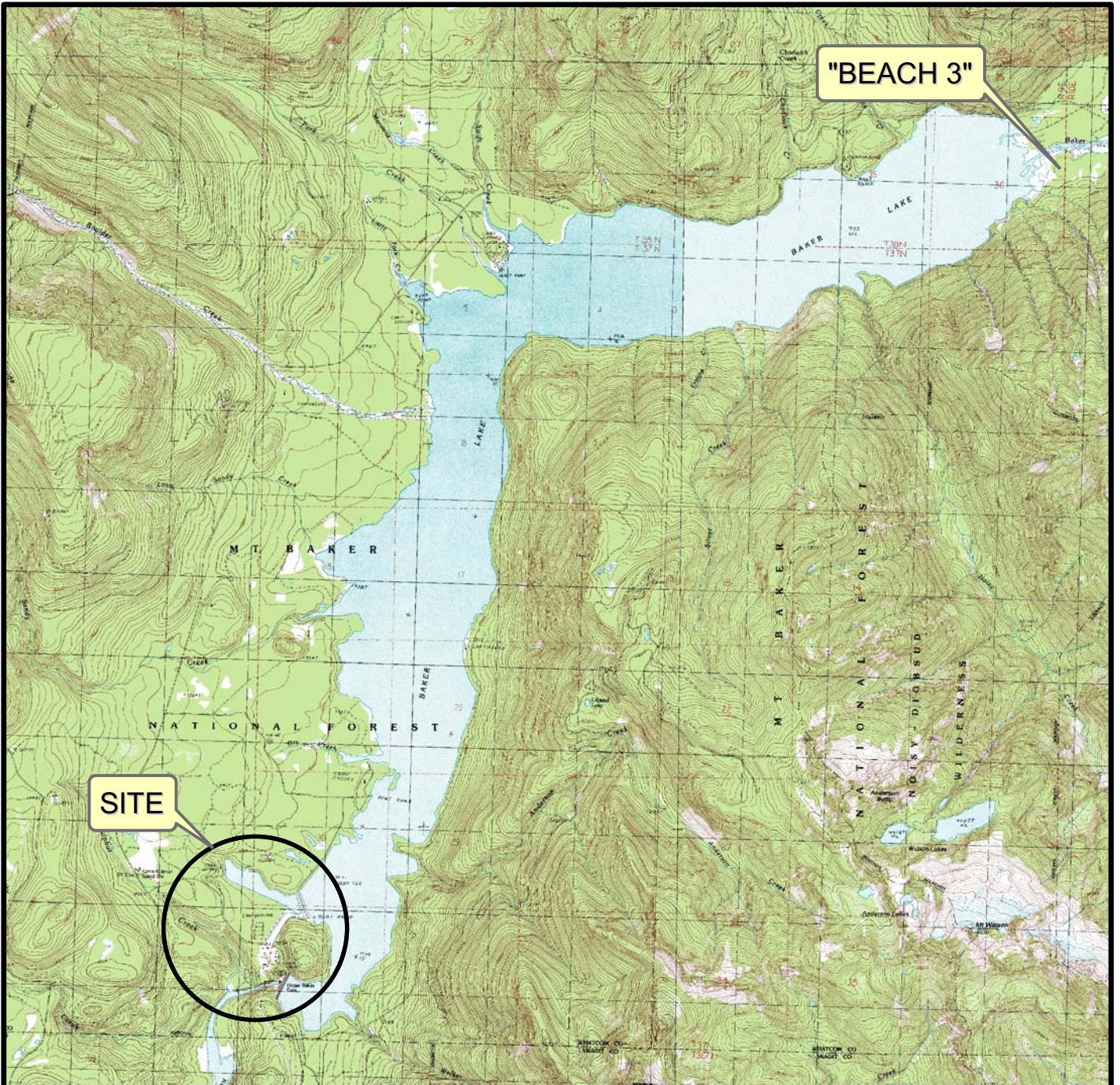

Data Sources: Interstates, state routes, and roads from TIGER 2000. County boundaries, cities, and waterbodies from Department of Ecology.

All locations are approximate.

Lambert Conformal Conic  
Washington State Plane North  
North American Datum 1983

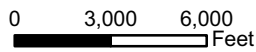

Note: This drawing is for informational purposes. It is intended to assist in showing features discussed in an attached document.

It is unlawful to copy or reproduce all or any part thereof, whether for personal use or resale, without permission.

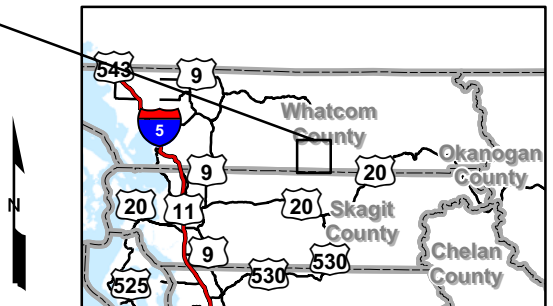

VICINITY MAP

FIGURE 1



06/06/05

TCM:GRL:SCY

TACO\0\0186634\00\CAD\T600\018663400\_T6\_UB\_FIG-2.dwg

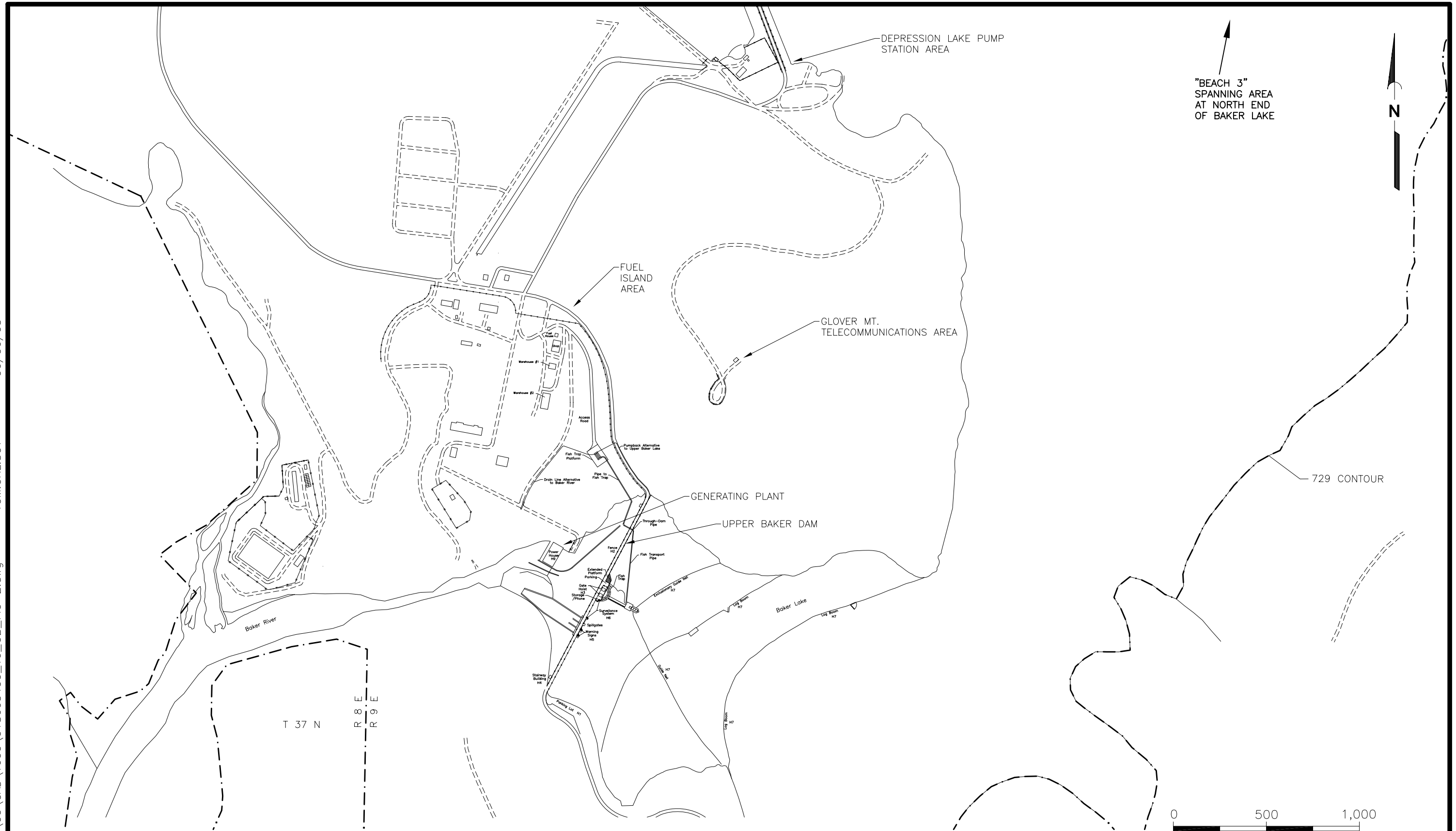

Notes: 1. The locations of all features shown are approximate.  
 2. This figure is for informational purposes only. It is intended to assist in the identification of features discussed in a related document. Data were compiled from sources as listed in this figure. The data sources do not guarantee these data are accurate or complete. There may have been updates to the data since the publication of this figure. This figure is a copy of a master document. The master hard copy is stored by GeoEngineers, Inc. and will serve as the official document of record.  
 Reference: Drawing provided by Puget Sound Energy.

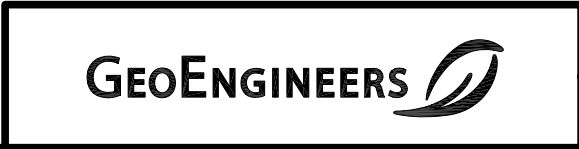

**SITE PLAN-UPPER BAKER GENERATION PLANT**  
**FIGURE 2**

BAK.20090325.0094.PSE.WDOE

07/22/05

TCM:GRL:SCY

TACO\0\0186634\00\CAD\T600\018663400\_T6\_UB\_FIG-3.dwg

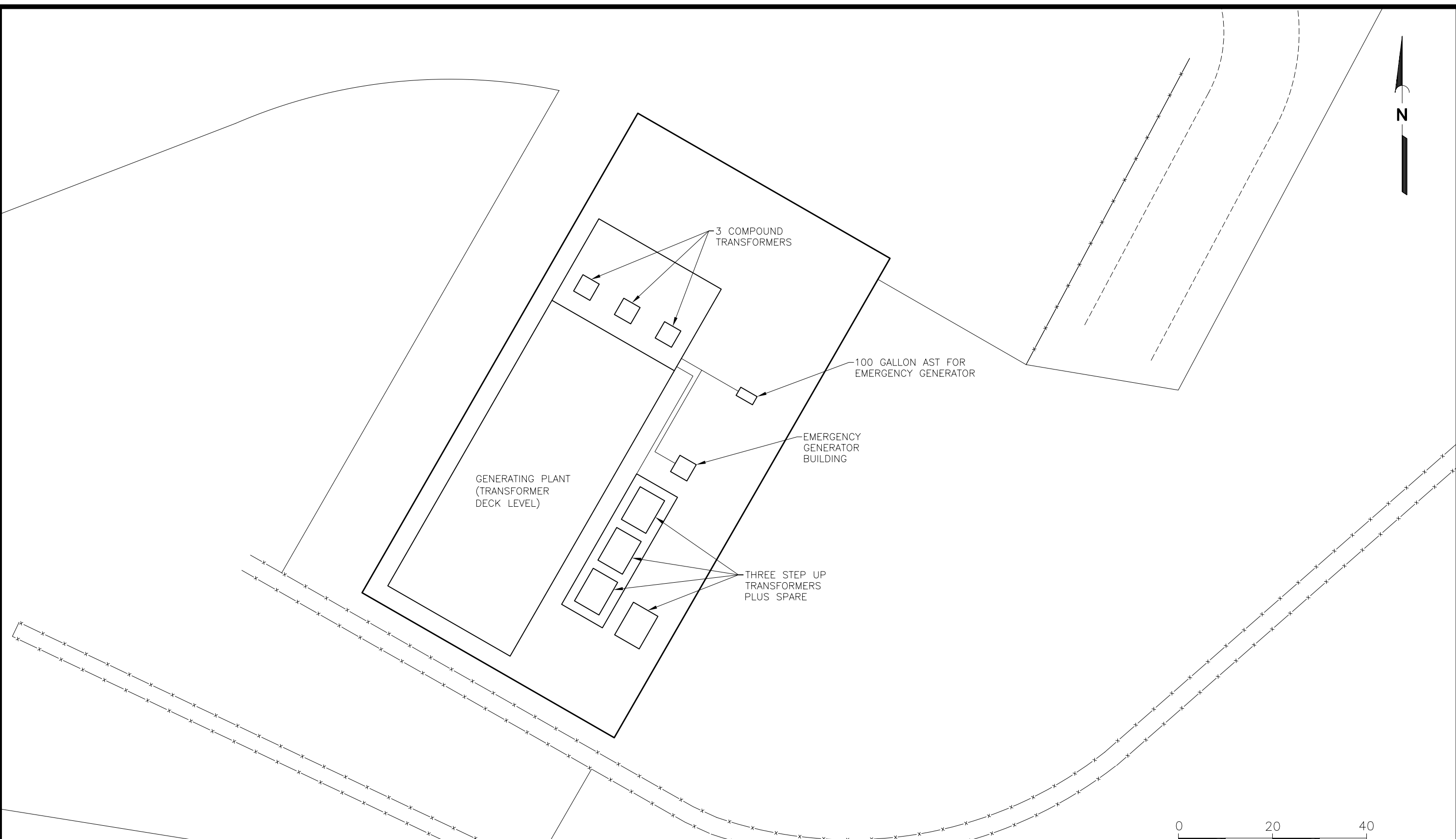

Notes: 1. The locations of all features shown are approximate.  
 2. This figure is for informational purposes only. It is intended to assist in the identification of features discussed in a related document. Data were compiled from sources as listed in this figure. The data sources do not guarantee these data are accurate or complete. There may have been updates to the data since the publication of this figure. This figure is a copy of a master document. The master hard copy is stored by GeoEngineers, Inc. and will serve as the official document of record.  
 Reference: Drawing provided by Puget Sound Energy.

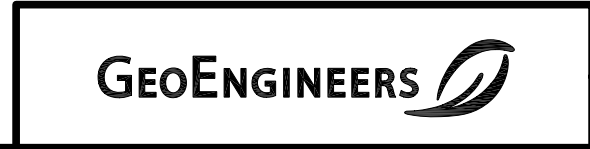
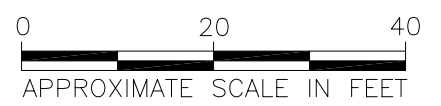

**SITE PLAN-UPPER BAKER GENERATION PLANT**  
**FIGURE 3**

06/29/05

TCM:GRL:SCY

TACO\0\0186634\00\CAD\T600\018663400\_T6\_UB\_FIG-4.dwg

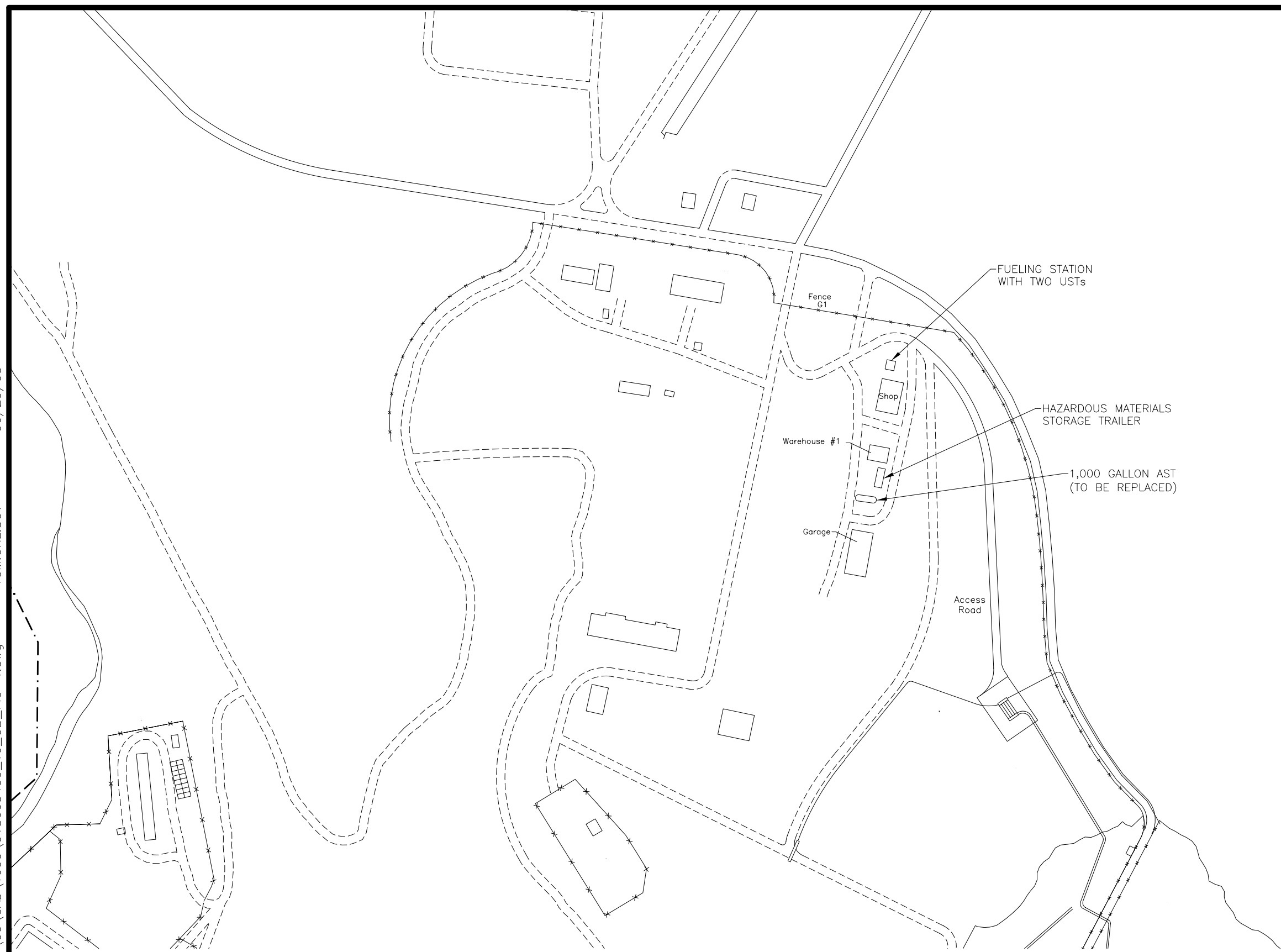
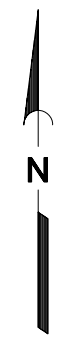

Notes: 1. The locations of all features shown are approximate.  
 2. This figure is for informational purposes only. It is intended to assist in the identification of features discussed in a related document. Data were compiled from sources as listed in this figure. The data sources do not guarantee these data are accurate or complete. There may have been updates to the data since the publication of this figure. This figure is a copy of a master document. The master hard copy is stored by GeoEngineers, Inc. and will serve as the official document of record.

Reference: Drawing provided by Puget Sound Energy.

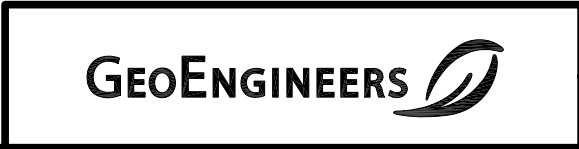
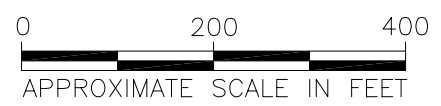

**SITE PLAN-FUEL ISLAND AREA**

**FIGURE 4**

08/14/08

TCM:GRL:SCY

TACO\0\0186634\00\CAD\T600\018663400\_T6\_UB\_FIG-5.dwg

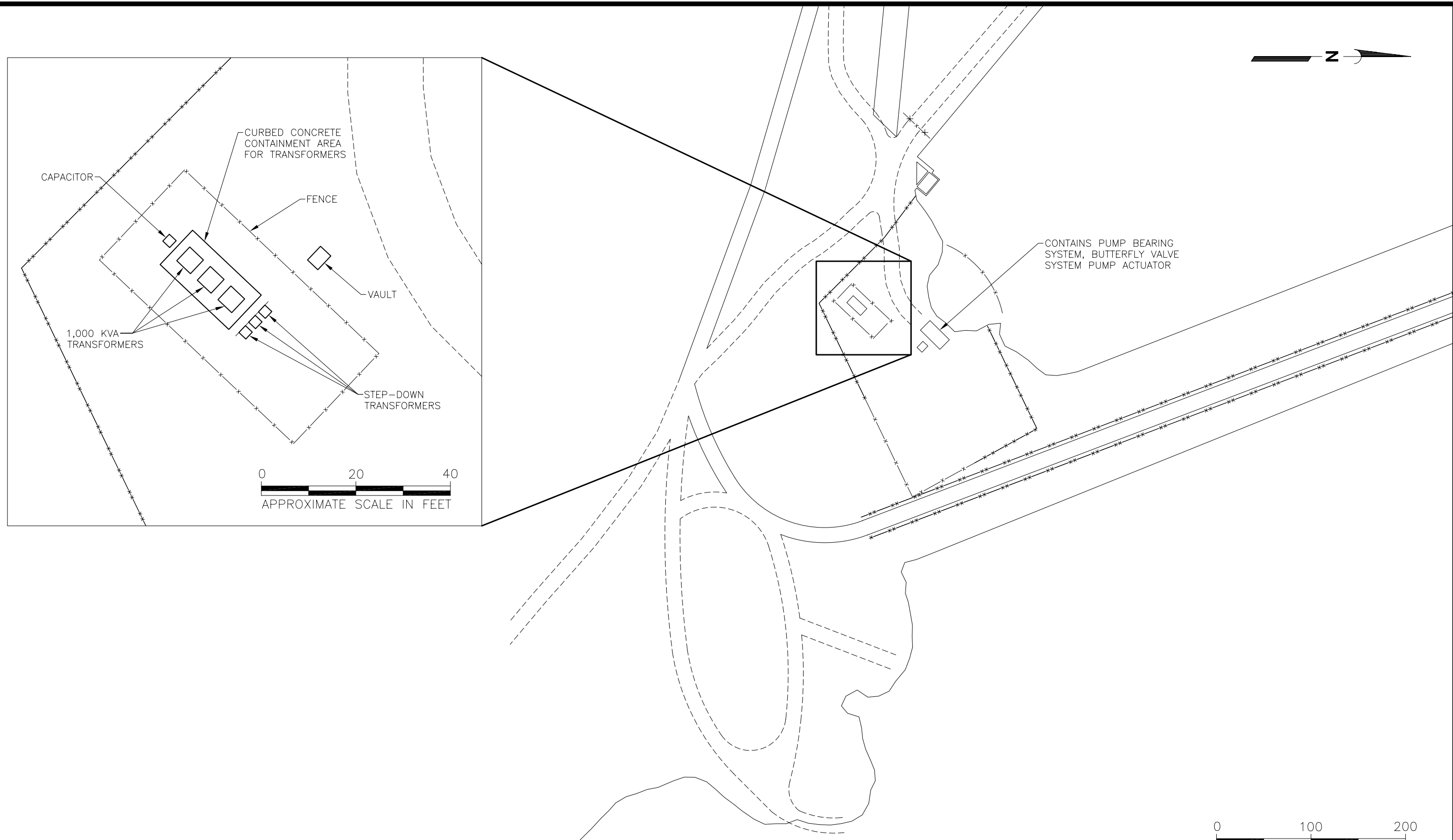

Notes: 1. The locations of all features shown are approximate.  
 2. This figure is for informational purposes only. It is intended to assist in the identification of features discussed in a related document. Data were compiled from sources as listed in this figure. The data sources do not guarantee these data are accurate or complete. There may have been updates to the data since the publication of this figure. This figure is a copy of a master document. The master hard copy is stored by GeoEngineers, Inc. and will serve as the official document of record.

Reference: Drawing provided by Puget Sound Energy.



DEPRESSION LAKE PUMP STATION AREA

FIGURE 5

**APPENDIX A**  
**CERTIFICATION OF THE APPLICABILITY OF THE**  
**SUBSTANTIAL HARM CRITERIA**

---



**APPENDIX A  
CERTIFICATION OF THE APPLICABILITY OF THE  
SUBSTANTIAL HARM CRITERIA  
(FROM 40 CFR, PART 112, APPENDIX C, ATTACHMENT C-II)**

Does the facility transfer oil over water to or from vessels and does the facility have a total oil storage capacity greater than or equal to 42,000 gallons?

Yes  No

Does the facility have a total oil storage capacity greater than or equal to 1 million gallons and does the facility lack secondary containment that is sufficiently large to contain the capacity of the largest aboveground oil storage tank plus sufficient freeboard to allow for precipitation within any aboveground oil storage tank area?

Yes  No

Does the facility have a total oil storage capacity greater than or equal to 1 million gallons and is the facility located at a distance such that a discharge from the facility could cause injury to fish and wildlife and sensitive environments?

Yes  No

Does the facility have a total oil storage capacity greater than or equal to 1 million gallons and is the facility located at a distance such that a discharge from the facility would shut down a public drinking water intake?

Yes  No

Does the facility have a total oil storage capacity greater than or equal to 1 million gallons and has the facility experienced a reportable oil spill in an amount greater than or equal to 10,000 gallons within the last 5 years.

Yes  No

**Certification**

I certify under penalty of law that I have personally examined and am familiar with the information submitted in this document, and based on my inquiry of those individuals responsible for obtaining this information, I believe that the submitted information is true, accurate and complete.

Signature: \_\_\_\_\_

Name: John Jensen

Title: Manager, Hydro Services



***APPENDIX B***  
***PSE STANDARDS AND FORMS***

---

# OIL SPILL/SPCC/HAZ Training Roster

Date: \_\_\_\_\_

Location: \_\_\_\_\_

	NAME	SIGNATURE	EMP. #	JOB TITLE	MAIL STOP
1					
2					
3					
4					
5					
6					
7					
8					
9					
10					
11					
12					
13					
14					
15					
16					
17					
18					
19					
20					
21					
22					
23					
24					
25					
26					
27					
28					



# SPILL REPORT FORM OR VACTOR WASTE DISPOSAL FORM

NO. 51007

BAK.20090325.0094.PSE.WDOE

*Use a separate form for each device.*

DEVICE TYPE	CO-ID NUMBER	NAMEPLATE OIL AMOUNT <span style="float: right;">GALS.</span>
SERIAL NUMBER	MFG	KVA
GRID NUMBER	INCIDENT / DAMAGE CLAIM NUMBER	

**PCB Content Information:** \_\_\_\_\_ ppm

- Verified by:  MFG Nameplate  PCB Field Test Kit (verify concentration)  
 PSE Database  Sample required for undocumented PCB information  
 Rush sample obtained by \_\_\_\_\_

### SPILL INFORMATION

DATE OF SPILL	TIME <span style="float: right;">am / pm</span>	DEVICE TAKEN TO
ADDRESS/LOCATION OF SPILL		
ESTIMATED QUANTITY <span style="float: right;">GALS.</span>	DATE SPILL CLEAN UP STARTED	DATE SPILL CLEAN UP COMPLETED

**Cause of Spill:**

- |  |  |  |                                      |   |
|--|--|--|--------------------------------------|---|
| <input type="checkbox"/> Equipment failure | <input type="checkbox"/> Car-pole accident | <input type="checkbox"/> Storm event   | <input type="checkbox"/> Bird/Animal | <input type="checkbox"/> Dug-up underground |
| ___ a. Corrosion                           | <input type="checkbox"/> Seepage from case | <input type="checkbox"/> Tree/Branches | <input type="checkbox"/> Vandalism   | <input type="checkbox"/> System Oil         |
| ___ b. Electrical Overload                 | <input type="checkbox"/> Other _____       |  |                                      |   |
| ___ c. Other                               |  |  |                                      |   |

### CLEAN-UP ACTIVITIES

- |   |  |  |
|---|--|--|
| <input type="checkbox"/> Contained oil on ground              | <input type="checkbox"/> Cleaned up spilled oil          | <input type="checkbox"/> Made final check of spill scene   |
| <input type="checkbox"/> Obtained oil sample in sample bottle | <input type="checkbox"/> Removed contaminated soil       | <input type="checkbox"/> Picked up oil contaminated debris |
| <input type="checkbox"/> Removed faulty transformer/device    | <input type="checkbox"/> Removed contaminated vegetation | <input type="checkbox"/> Wiped down surfaces twice         |
| <input type="checkbox"/> Replaced with CO - ID _____          | <input type="checkbox"/> Other _____                     | Solvent _____  |

VACTOR TRUCK REQUIRED? <input type="checkbox"/> YES <input type="checkbox"/> NO	CLEANUP CONTRACTOR
---	--------------------

**PCB content required before disposal at waste facility.**

NAME OF CLEAN-UP CREW	
UTILITY CONTRACTOR	
SITE FOREMAN	PHONE NO.

- |  |  |
|--|--|
| <b>Materials removed from site:</b><br>_____ # of 55-gal drums<br>_____ gals of liquid<br>_____ cubic yds of solids<br>_____ # of trash bags | <b>Taken to:</b><br><input type="checkbox"/> PSE SKC-WMF<br><input type="checkbox"/> TPS<br><input type="checkbox"/> CSR<br><input type="checkbox"/> Other _____ |
|--|--|

FOREMAN NAME (PRINT NAME)	SIGNATURE	DATE
CLEAN-UP SUPERVISOR (PRINT NAME)	SIGNATURE	DATE

WHITE: ENVIRONMENTAL SERVICES    CANARY: WITH SITE FOREMAN    PINK: VACTOR TRUCK DRIVER

**FACILITY INSPECTION FORM**

Facility Name: \_\_\_\_\_ Date of Inspection: \_\_\_\_\_

**WEEKLY**

If facility doesn't have a PCB storage area, inspection can be performed monthly.

<b>A. All Items In The PCB Temporary Storage Area</b>	<b>YES</b>	<b>NO*</b>
1 Is the temporary storage area roped off and marked with PCB signs?		
2 Are items and containers properly labeled, dated and logged?		
3 Have all items or containers been inspected for leaks?		
4 Have all leaks and spills been responded to?		
5 Are all damaged items or containers protected from the weather?		
6 Are secondary containment structures provided where necessary and in good condition?		
7 Are all items in temporary storage known or assumed $\geq$ 50 ppm PCB?		
8 Are all items and containers under the 30 day storage limit?		

Comments or Corrective Actions:  
 \_\_\_\_\_  
 \_\_\_\_\_

<b>B. All Items In The Hazardous Waste Accumulation Area (Hazardous Waste Manual)</b>	<b>YES</b>	<b>NO*</b>
1 Is the area neat and uncluttered with the drums easily accessible?		
2 Is the area clearly identified for waste accumulation?		
3 Is secondary containment present and in good condition for liquid wastes?		
4 Are all drums appropriately labeled and are the labels legible?		
5 Are the lids secured on all the drums?		
6 Have the dates on the drums been checked for disposal deadlines? (e.g. UW <1 year)?		

Comments or Corrective Actions:  
 \_\_\_\_\_  
 \_\_\_\_\_

<b>C. SPCC Plan and All Oil Filled Devices In Storage</b>	<b>YES</b>	<b>NO*</b>
1 Are all oil filled devices and containers properly labeled?		
2 Have all oil filled devices and containers been inspected for leaks?		
3 Have all leaks and spills been responded to?		
4 Is secondary containment present and in good condition?		
5 Are spill kits or Absorbant available/complete at fueling islands?		

Comments or Corrective Actions:  
 \_\_\_\_\_  
 \_\_\_\_\_

<b>D. House Keeping</b>	<b>YES</b>	<b>NO*</b>
1 Is the perimeter fence clear of all trash and debris?		
2 Are ditches and catch basins onsite clear of trash and debris?		
3 Is the site in good condition and well kept?		
4 Are all containers labeled with contents?		
5 Is the dumpster free of any hazardous waste items or treated wood?		

Comments or Corrective Actions:  
 \_\_\_\_\_  
 \_\_\_\_\_

<b>E. Asbestos Storage (Georgetown, Tacoma, Olympia)</b>	<b>YES</b>	<b>NO*</b>
1 Has the asbestos storage container for conversion burners been checked? -- If asbestos is present contact Nadine Loken @ 253-437-6783		

Comments or Corrective Actions:  
 \_\_\_\_\_  
 \_\_\_\_\_

FACILITY NAME:  
 ENVIRONMENTAL COORDINATORS NAME:  
 ENVIRONMENTAL COORDINATORS SIGNATURE: \_\_\_\_\_ DATE: \_\_\_\_\_

\*If any of the responses are "NO", please forward a copy of this inspection to Gordon Johnson. Fax: 360-475-7017.  
 Due to the record retention requirements of various environmental laws, inspections must be kept on file and available at each facility for 5 years.



# FACILITY INSPECTION

Monthly  
Quarterly

## MONTHLY

### A. Underground Storage Tanks (USTs) Without Automatic Leak Detection (SM-06)

YES	NO*
<input type="checkbox"/>	<input type="checkbox"/>
<input type="checkbox"/>	<input type="checkbox"/>
<input type="checkbox"/>	<input type="checkbox"/>

1. Daily variance < 100 gallons on each tank during the month?
2. Monthly fuel reconciliation sheet filled out, and sum of daily variances < 100 gallons for each tank?
3. Fuel Pumps calibrated within the last year?

Comments: \_\_\_\_\_

\_\_\_\_\_

\_\_\_\_\_

### B. All Items In The Hazardous Waste Accumulation Area (Hazardous Waste Manual)

YES	NO**
<input type="checkbox"/>	<input type="checkbox"/>

1. Monthly Waste Accumulation Log report completed?

Comments: \_\_\_\_\_

\_\_\_\_\_

\_\_\_\_\_

## QUARTERLY

### Oil Trap Vault (SPCC Plan)

YES	NO***
<input type="checkbox"/>	<input type="checkbox"/>
<input type="checkbox"/>	<input type="checkbox"/>
<input type="checkbox"/>	<input type="checkbox"/>

1. Oil Trap Vaults and Catch Basins clean with no oil film or scum on the water?
2. Are the Catch Basins & Ditches free of sand/silt accumulation & functioning properly?
3. Have the Vaults, Catch Basins & Ditches been cleared of sand/silt accumulations within the last year?
4. Has SPCC Plan training been completed within the last year?

Comments: \_\_\_\_\_

\_\_\_\_\_

\_\_\_\_\_

FACILITY NAME: \_\_\_\_\_

INSPECTOR'S NAME: \_\_\_\_\_

INSPECTOR'S SIGNATURE: \_\_\_\_\_ DATE: \_\_\_\_\_

\* If you suspect a leak consult the Stores Manual SM-06

\*\* If any of the responses are NO please forward a copy to Environmental Compliance OBC-11N

\*\*\* For corrective action consult the SPCC Plan

NOTE: Completed copies of this form must be kept on file for 5 years



## Scope

This standard covers Puget Sound Energy's procedures for responding to oil spills.

---

## In This Standard

These topics are covered in this standard:

Topic	See Page
Definitions	2
Responding to an Oil Spill	2
Responsibilities	3
Safety and Handling	4
Personal Protective Equipment	5
First Aid	5
Industrial Injury and Illness	6
Tools, Materials, and Equipment	6
Spill Response	9
Oil Spill Notification	11
Spill Characterization	13
Spill Cleanup	14
Cleanup Guidelines for Specific Circumstances	14
Decontamination of Equipment	20
Vactor Truck Waste Accumulation, Transport, and Disposal	20
Record Keeping	21

---

### **WARNING!**

These procedures are required by law and shall be followed by both Puget Sound Energy employees and contract labor crews. Failure to do so could result in citations or fines for noncompliance.

---



## Definitions

Table 1

Definitions for this standard

Term	Definition
Oil	Oil of any kind or any form including petroleum, fuel oil, sludge, and oil refuse. Oil contained in transformers, capacitors, and other equipment sometimes contains PCBs.
PCBs	Polychlorinated biphenyls are a group of synthetic organic chemicals that can be toxic and are found in some dielectric fluids.
Spill Report Form (Form 1184)	A carbon-copy form that properly documents a spill. The form is used by the person who discovers the spill to document and report the spill event and what was done in response.
Spill Waste	Waste generated as a result of an oil spill including collected liquids, soil, rags, used Personal Protective Equipment, and other debris generated as a result of a spill cleanup.

## Responding to an Oil Spill

Oil spills can occur during transfer of oil, (e.g., when draining or filling equipment or containers), or from equipment that has failed or been damaged recently or in the past. Most spills are discovered when a crew is dispatched by System Operations to respond to a power outage. In the event of an oil spill, Puget Sound Energy’s policy is to respond promptly and thoroughly. Spill containment and/or cleanup must be initiated immediately.

### Basic Steps for Responding to All Spills

The following basic steps apply for responding to all spills. Refer to the Spill Response section of this standard for the complete procedure.

Step	Action
1	If a spill or release occurs, <i>think safety</i> . Take actions to protect yourself and others from exposure to the spill or release.
2	Keep the public and unprotected personnel away from the spill area.
3	Locate and stop the source and flow of the spill or leak, if you are qualified and it is safe to do so.
4	Secure the area.
5	Decide who should respond and notify appropriate parties.

*Continued on next page*

**Spills Could Contain PCBs**

Tests have shown that oil from some transformers, capacitors, and other electrical equipment may contain Polychlorinated Biphenyls (PCBs). The Environmental Protection Agency (EPA) has many requirements for the management of PCBs under the Toxic Substances Control Act (TSCA), which addresses the manufacturing, processing, distribution in commerce, use, cleanup, storage, and disposal of PCBs.

**Table 2**

Who to call for help

Contact	Phone
Environmental Services 24-hr Spill Pager	(206) 994-3186
Environmental Services Waste Management Facility	(360) 340-3716 or (253) 437-6783
Safety Department	Contact Eastside System Operations

**Responsibilities**

**Employees**

Employees with vehicles that transport oil or oil-filled equipment must carry equipment for cleaning up minor spills.

The employee who discovers or is first notified of the spill is responsible for coordinating initial response.

**Supervisor, Crew Foreman, and System Operations**

Responsible for determining whether the cleanup is to be completed by the Line/Wire Crew or coordinated by Environmental Services, who will request assistance from one or more spill response consultants.

Internal spill reporting is to be handled in accordance with *Table 7*.

**If Cleanup is Handled by Line/Wire Crew**

The Crew Foreman is responsible for:

- Coordinating and monitoring the spill cleanup activities.
- Submitting a draft Spill Report Form (Form 1184) to their Supervisor and Environmental Services.

Either the Crew Foreman or spill response consultant, (under the direction of Environmental Services) is responsible for:

- Decontaminating equipment.
- Accumulating, labeling, and packaging spill waste and out-of-service equipment and transporting it to the nearest Service Center or other approved storage area in accordance with Standard 0150.3125.

The Supervisor is responsible for submitting the completed Spill Report Form (Form 1184) to Environmental Services.

Line/Wire Crew employees involved in spill sampling or cleanup are responsible for wearing the appropriate personal protective equipment (PPE).

*Continued on next page*

## Responsibilities, *Continued*

### Vector Trucks at Cleanup Site

If a vector truck is called to respond, the Vector Truck Operator must verify with the Crew Foreman the PCB content of the oil that was released prior to beginning work.

The Vector Truck Operator is also responsible for:

- Contacting the South King Waste Management Facility to coordinate disposal of vector truck wastes. The operator should ensure that the PCB concentration of the source oil is known prior to disposing any vector truck load.
- Completing the logbook and giving a copy of the Spill Report Form (Form 1184) to the Waste Management Facility (WMF) personnel. The WMF personnel are responsible for processing the discharged load.

### If Cleanup is Handled by Environmental Services

The Environmental Services spill response consultant is responsible for:

- Mobilizing spill response contractors (if necessary) to spill site.
- Coordinating and monitoring the spill cleanup activities.
- Documenting the spill and cleanup activities in Spill Report Form (Form 1184).

### Environmental Services and/or Consultant

Environmental Services, or when requested, their spill response consultant is responsible for:

- Any external reporting required, depending on the spill.
- Determining the probable PCB concentration of the oil spilled if it was from electrical equipment.
- Conducting and documenting any sampling of the equipment and/or site that may be necessary.

### Manager of Environmental Services

The Manager of Environmental Services is responsible for maintaining PSE's overall compliance with the applicable environmental regulations.

## Safety and Handling

Oil and oil-contaminated materials are potentially hazardous. Sometimes oil contains PCBs. This section describes the personal protective equipment that should be worn during oil spill response and first aid procedures that should be used to help anyone who has come into contact with PCB-containing oil.

Two very important safety tips to remember:

- If there is fire, keep away from the area and protect yourself from inhaling smoke or vapors. Vapors generated during the burning of PCBs can present a serious health risk.
- Avoid direct skin contact with electrical equipment fluids and soot.

### CAUTION!

Wear personal protective clothing and equipment during all phases of spill cleanup.

## Personal Protective Equipment

- Personal protective equipment (PPE) is to be worn during all phases of oil sampling and spill cleanup. This includes safety glasses, gloves, coveralls and shoe covers. See the Tools, Materials, and Equipment section of this standard for a list of appropriate PPE.
- When liquids are handled in an enclosed area, use a respirator. Wear a face shield to protect from liquid splatter.
- Consider sealing your coveralls to your boots with tape.

## First Aid

If eyes, skin or clothing come in contact with PCBs or if PCBs are ingested or inhaled, follow these first aid treatments. If medical assistance is necessary, call 911 or take employee to the hospital and have the Supervisor contact the Safety Department immediately.

## Clothing Contact

If clothing comes in contact with PCBs:

Step	Action
1	Remove contaminated clothing as soon as possible.
2	Place clothing in a plastic bag; seal and label it.
3	Place bags in a drum.
4	Notify the area Environmental Coordinator of the location of the drum for proper disposal.

## Eye Contact

If eyes come in contact with PCBs:

- Flush eyes with water or eye irrigation solution for at least 15 minutes and take employee to emergency care.

**NOTE:** If flushing does not relieve symptoms, continue flushing on the way to emergency care.

## Ingestion

If PCBs are ingested:

- The employee is to be taken to the hospital immediately.
- Contact the Safety Department immediately.

## Inhalation

If PCBs are inhaled:

- If nausea, breathing difficulty or dizziness occurs, the employee is to be taken to the hospital immediately.
- Contact the Safety Department immediately.

*Continued on next page*

## First Aid, *Continued*

### Skin Contact

If skin comes in contact with PCBs:

Step	Action
1	Remove as much of the oil as possible with paper towels.
2	Clean skin immediately with soap and water. If soap and water are not available, use waterless hand cleaner.
3	Wipe with clean paper towels or rags.
4	Repeat washing and wiping three times.
5	Rinse skin thoroughly with water.
6	Dry skin.
7	If irritation continues after washing, get medical attention.
8	Discard used towels or rags in plastic bags; seal and place bags in a drum.
9	Notify the area Environmental Coordinator of the location of the drum for proper disposal.

## Industrial Injury and Illness

Every injury and illness is to be reported. The employee's Supervisor shall complete an Industrial Injury & Illness Report (Form 3892) and submit it to the Safety Department.

## Tools, Materials, and Equipment

**Table 3**

Personal Protective Equipment

Category	Item	MID	Examples of Appropriate Use
Air Quality	Half-mask respirator	6876000 small 6876100 medium 6876200 large	In an enclosed area or when concerned about splash from spray or general air quality because of smoky or dusty conditions.
	Organic vapor/acid gas respirator cartridge	6806000 yellow 6806300 yellow/purple, with HEPA	

*Continued on next page*

Category	Item	MID	Examples of Appropriate Use
Eye Protection	Face shield	6829000 nonhard hat 6830000 hat-mounted 6888000	When transferring liquids from containment into a drum or between drums any time splash could occur or when air is dusty.
	Goggles	6827300	
	Safety glasses with side shields	6827000 6827101	
First Aid	Portable eye wash kit	6826400	If liquids contact the eye or eyelid.
	Waterless hand cleaner	4461001	To clean skin areas other than eyes.
Hand Protection	Gloves Nitrile	6857900 Size 9 (15 mil) 6858000 Size 10 (15 mil)	When hand contact with liquids is possible, (e.g., handling leaking or contaminated equipment, soil, or surfaces).
Skin and Clothing Protection	Disposable coveralls, rated for hazardous materials	6811000 small 6811100 medium 6811200 large 6811300 extra large	Strenuous cleanup, such as for a large oil spill from ruptured equipment.
	Disposable coveralls, Tyvek	6810600 small 6810700 large 6810800 extra large	Nonstrenuous cleanup, short-term exposure, dusty environment.
Skin and Shoe Protection	Disposable shoe covers	6811500 medium 6811600 extra large 6811700 giant	All cleanup operations.

**Table 4**

Labels and forms

Category	Item	MID	Examples of Appropriate Use
Injuries and Illnesses	Employee Injury Packet	Available from PSE Supervisor	When there is an injury or illness because of the spill.
Spill Reporting	Spill Report Form (Form 1184)		All spills.

**NOTE:** Other tools and materials are required for waste packaging and labeling, in accordance with Standard 0150.3125.

*Continued on next page*

## Tools, Materials, and Equipment, *Continued*

Figure 1 Example of Spill Report Form (Form 1184)



**PUGET  
SOUND  
ENERGY**

**SPILL REPORT FORM**  
OR  
**VACTOR WASTE DISPOSAL FORM**  
*Use a separate form for each device.*

NO. **42750**

Device Type \_\_\_\_\_ CO-ID Number \_\_\_\_\_ Nameplate Oil Amount \_\_\_\_\_ gals.  
 Serial Number: \_\_\_\_\_ MFG: \_\_\_\_\_ KVA: \_\_\_\_\_

**PCB Content Information:** \_\_\_\_\_ ppm  
 Verified by:  MFG Nameplate/SRS Screen 7  
 PCB Report  
 Sample required for undocumented PCB information

**PCB Analysis not required:**  
 Hydraulic/Motor oil  
 Diesel/Gasoline spill  
 Chemical spill

**ANALYSIS RESULTS**  
 Notify: \_\_\_\_\_ Phone: \_\_\_\_\_

**SPILL REPORT**  
 Date of spill \_\_\_\_\_ Time \_\_\_\_\_ am/pm SVC-CTR/OP Base \_\_\_\_\_  
 Address/Location of spill: \_\_\_\_\_  
 Estimated Quantity \_\_\_\_\_ gals. Date spill clean up started \_\_\_\_\_ Date spill clean up completed \_\_\_\_\_

**Cause of Spill:**  
 Equipment failure  
     \_\_\_ a. Corrosion  
     \_\_\_ b. Electrical Overload  
     \_\_\_ c. Other  
 Car-pole accident  
 Seepage from case  
 System Oil  
 Storm event  
 Tree/Branches  
 Bird/Animal  
 Vandalism  
 Dug-up underground  
 Other

**Comments:** \_\_\_\_\_  
 \_\_\_\_\_  
 \_\_\_\_\_

Was this spill preventable? yes / no Explain \_\_\_\_\_

**CLEAN-UP ACTIVITIES**  
 Contained oil on ground  
 Obtained oil sample in sample bottle  
 Removed faulty transformer/device  
 Replaced with CO - ID \_\_\_\_\_  
 Cleaned Device Case  
 Cleaned up spilled oil  
 Removed contaminated soil  
 Removed contaminated vegetation  
 Made final check of spill scene  
 Picked up oil contaminated debris  
 Wiped down surfaces twice  
     Solvent \_\_\_\_\_  
 Other \_\_\_\_\_

**Depth and amount of soil excavated/Comments:** \_\_\_\_\_  
 \_\_\_\_\_

**Vactor Truck Required?** yes/no  Puget Truck  Contract Truck/Company Name \_\_\_\_\_  
**PCB content required before disposal at waste facility.**

Draw diagram on the **back of white copy** of this form showing location of spill in relation to nearby streams, ponds, lakes, residences, commercial property, parks, etc. Include approximate distances. The diagram should show the extent of the visible traces of oil and extent of the area cleaned.  
 Puget Crew  Contract Crew Company Name \_\_\_\_\_  
 Names of clean-up crew: \_\_\_\_\_  
 Name, address and telephone number of witness: *(Use back of report for additional witnesses)*  
 \_\_\_\_\_  
 \_\_\_\_\_

FOREMAN \_\_\_\_\_ Date \_\_\_\_\_  
print name signature

OPS SUPV \_\_\_\_\_ Date \_\_\_\_\_  
print name signature

1184 1/98  
 1. Environmental Services - MER-04S : White  
 2. With Chain of Custody: Canary  
 3. File Copy: Pink  
 4. Vactor Truck Driver: Goldenrod



**Table 5**

Spill response equipment

Category	Item	MID	Examples of Appropriate Use
Cleaning	Absorbent granules	4460800	Capturing small amounts of free liquids.
	Brooms		Sweeping used absorbent into piles.
	Oil-absorbent sheets	7482500	Capturing small amounts of free liquids.
	Rags	7474500	Wiping down equipment.
	Shovels		Shoveling wastes into drums.
Sampling	Chain of Custody Report (Form 1257)		For all samples of the site or spill wastes.
	Oil sample collection kits	7408600	Sampling oil in damaged electric equipment.

**NOTE:** Other tools and materials are required for waste packaging and labeling, in accordance with Standard 0150.3125.

## Spill Response

This section covers the procedure for responding to and cleaning up oil spills.

### Discovery and First Steps

For spills, the sooner containment/cleanup is initiated, the more effective it will be.

Step	Action
1	<p>If a spill or release occurs, <b>THINK SAFETY</b>. Take actions to protect yourself and others from exposure to the spill or release.</p> <ul style="list-style-type: none"> <li>▪ Drive cautiously when approaching and leaving a spill site.</li> <li>▪ Avoid driving through the spill area. Oil spread by traffic expands the area of contamination.</li> <li>▪ If there is a fire, maintain a safe distance from it.</li> <li>▪ Ensure that all the equipment involved is de-energized.</li> <li>▪ Assume all oil contains PCBs until proven otherwise.</li> <li>▪ Use the proper PPE.                             <ul style="list-style-type: none"> <li>– Protect yourself from skin contact.</li> <li>– Prevent contamination of clothing.</li> </ul> </li> </ul>
2	Keep the public and unprotected personnel away from the spill area.

*Continued on next page*

## Spill Response, *Continued*

Step	Action
3	<p>Locate and stop the source and flow of the spill or leak, if you are qualified and it is safe to do so.</p> <ul style="list-style-type: none"> <li>▪ If leaking cannot be stopped, place a container (bucket, plastic bag, absorbent pads, kitty litter, or whatever is available) beneath the leak to prevent continued migration of oil away from the spill area.</li> <li>▪ Divert the oil flow to prevent the spill from entering nearby water bodies or floor drains. Give first priority to spills that could or have endanger(ed) water sources.</li> <li>▪ If safe to do so, plug holes, reposition the equipment and/or shut valves.</li> <li>▪ Use whatever materials and equipment are available to confine the spill and prevent further contamination of the area. Do not wait for a spill containment kit to arrive.</li> </ul>
4	<p>Secure the area.</p> <ul style="list-style-type: none"> <li>▪ Use barricades or warning tape to form an adequate buffer around and beyond any visible traces of oil. A spill in a vault does not require barricading or tape.</li> <li>▪ If cleanup is delayed, the area shall remain barricaded. Cover the spill with plastic sheeting.</li> <li>▪ Limit the number of people entering the spill area.</li> </ul>
5	Decide who should respond and notify appropriate parties.

### Deciding Who Should Respond

Line/Wire Crews may either clean up the spill themselves according to this standard or may request assistance by calling the Environmental Services 24-Hour Spill Pager (see *Table 2*). This decision is made by the Crew Foreman, Supervisor, or System Manager in accordance with the guidelines in *Table 6*.

**Table 6**

Decision guidelines

Spill characteristics	Who should respond
Large spill that exceeds the available resources of the crew	Environmental Services
Spill from equipment known to contain PCBs	Environmental Services
Spill towards or near surface water or drains	Environmental Services
Spill in a sensitive area	Environmental Services
Spill that has a wide area of contamination	Environmental Services
Release that involves fire	Environmental Services
Spill around energized equipment	Line/Wire Crews and/or Environmental Services
Small spill that can be cleaned up using the available resources of the crew	Line/Wire Crews and/or Environmental Services

## Oil Spill Notification

A spill or other unintentional release into the environment may give rise to a variety of reporting, response, and record-keeping requirements, generally depending upon what was spilled, the amount spilled, and the time, location, and effects of the spill. Every spill should be reported to Environmental Services to facilitate compliance with the applicable requirements.

---

### Information to Report

Be prepared to report the following information:

- Date and time of the spill.
- Spill location.
- Spill source.
- Cause and circumstances of the spill.
- Existing or potential hazards, if any.
- Information on equipment involved including serial number, manufacturer, Company ID number, and type of equipment.
- Identity of the material spilled and information on PCB content (if shown on the nameplate).
- Total volume of oil contained in the equipment (if shown on the nameplate).
- Approximate quantity (e.g., estimated volume) of spill.
- Contact name and phone or radio number.
- Personal injuries or casualties, if any.
- Names of people exposed to oil or smoke.
- Corrective actions being taken and an approximate timetable to control, contain, and clean up the spill.
- Is the Line/Wire Crew equipped and trained to contain the spill?
- Has the oil reached water?
- Other unique or unusual circumstances.

Record all discussions, including people involved, time of the call, phone numbers, and any other information that may be useful for completing the Spill Report Form (Form 1184).

---

*Continued on next page*

## Oil Spill Notification, *Continued*

### Internal Reporting of Oil Spills

Table 7 shows the plan for ensuring that all appropriate parties are promptly notified of spill events.

**Table 7** Notification of appropriate parties

Person Responsible	Whom to Notify	When
Crew Foreman who discovers the spill	Supervisor	Immediately
Crew Foreman who discovers the spill	Submit draft Spill Report Form (Form 1184) to Supervisor.	Within 48 hours
Crew Foreman who discovers the spill or fire	Environmental Services 24-Hour Spill Pager (see <i>Table 2</i> ) <ul style="list-style-type: none"> <li>▪ Fax a copy of the draft Spill Report Form (Form 1184) as soon as it is available.</li> </ul>	Immediately if spill response assistance is needed.
Crew Foreman who discovers the spill or fire	Dispatcher/System Operations <ul style="list-style-type: none"> <li>▪ Fax a copy of the draft Spill Report Form (Form 1184) as soon as it is available.</li> </ul>	Immediately
Dispatcher/System Operations	Environmental Services 24-Hour Spill Pager (see <i>Table 2</i> )	Immediately for fires and for any release to water.  As soon as possible for other releases.
Dispatcher/System Operations	If there is a fire: <ul style="list-style-type: none"> <li>▪ Local Fire Department</li> <li>▪ PSE Emergency Contacts</li> <li>▪ Risk Management</li> <li>▪ Corporate Relations</li> </ul>	Immediately
Environmental Services Department	Report spill event to external regulatory agencies if required or appropriate.	Immediately or within regulatory deadlines.
Supervisor	Submit completed Spill Report Form (Form 1184) to Environmental Services.	Within 48 hours

*Continued on next page*

## External Reporting of Oil Spills

Environmental Services will make all necessary notifications to appropriate regulatory agencies when appropriate. It is imperative that the Environmental Services 24-Hour Spill Pager (see *Table 2*) be called promptly to report every spill, so that Environmental Services can assess the situation, determine whether external spill reporting is required, and make the appropriate notifications within the time frames specified.

---

## Spill Characterization

This section describes the procedure for characterizing the spilled material and the extent of contamination. A diagram should be drawn on the back of the white page of the Spill Report Form (Form 1184) to show the center and extent of contamination for each visible area of contamination.

---

## Determining PCB Concentration

Environmental Services will coordinate the response and cleanup for spills containing PCBs. Each piece of electrical equipment can contain different amounts of PCBs. Spills of oil with 50 ppm or greater of PCBs are subject to specific cleanup requirements.

Often the manufacturer will state the concentration of PCBs contained in the dielectric fluid on the equipment nameplate. Additionally a search by serial number (from the manufacturer's nameplate) can be used to query PSE's SAP database to determine if sample data already exists for the equipment.

**NOTE:** Analyses for PCB concentrations that were conducted prior to 1986, yellow stickers (less than 50 ppm of PCBs), and blue stickers (non-PCB) are no longer honored. Analyses must be performed to properly document the concentrations of PCBs in the oil.

---

## If Spill Occurs During or After Business Hours

If a spill occurs during business hours, contact Environmental Services to determine the probable PCB concentration. If the spill occurs after normal business hours, the Dispatcher or System Operations should contact the Environmental Services 24-Hour Spill Pager (see *Table 2*).

---

## Sampling the Spill Area

The spilled oil and contaminated area may need to be sampled to characterize the extent of the contamination. Such sampling, as well as post-cleanup sampling, is specifically required for spills of oil with 50 ppm or greater of PCBs. Contact the Environmental Services 24-Hour Spill Pager (see *Table 2*) or Environmental Services to coordinate any sampling that may be necessary.

---

## Spill Cleanup

A spill should be cleaned up either by the Line/Wire Crew that discovered it or by Environmental Services. When called to respond, Environmental Services uses one or more approved spill response contractors.

If there is a fire, the fire department will respond under the direction of an Incident Commander who will act as PSE's point of contact. Any fire involving PCBs will typically require the fire department's Hazardous Materials Unit.

### When Line/Wire Crews Clean Up the Spill

Crews should only respond themselves if the spill is small, it is not suspected to contain PCBs, and the crew has the necessary resources to respond properly.

- Facilities with hazardous materials have spill kits with absorbent pads, booms, and other materials for containing and cleaning up spills. Spill response materials are available through Stores. Follow instructions from your Supervisor or Environmental Coordinator.
- Small spills of liquids (less than about 5 gallons) should be collected with absorbent booms or pads to prevent discharge to drains, waterways, or other receptors.
- Prevent storm-water pollution by preventing petroleum-contaminated soils from coming into contact with rainwater. Covering the spill area with plastic sheeting will help reduce contamination migrating off-site.
- If petroleum contaminated soil is to be excavated, it should be collected preferably in closed, appropriately sized, leak-tight, labeled containers.
- All spilled material and contamination must be cleaned up in accordance with appropriate cleanup standards. Specific cleanup standards apply for spills of oil with 50 ppm or greater of PCBs, which should be handled by Environmental Services. Consult Environmental Services for any questions you may have.

## Cleanup Guidelines for Specific Circumstances

### Distribution Transformer Spill

Line/Wire Crews should request assistance from Environmental Services for spills from equipment that is known to contain PCBs. Contact the Environmental Services 24-Hour Spill Pager (see *Table 2*). If a PCB transformer develops a leak that runs off or is about to run off the surface of the transformer, the leak must be contained, cleanup must be initiated no later than 48 hours from finding the leak, and the transformer must be repaired or replaced.

For spills from equipment that is not known to contain PCBs:

Step	Action
1	Clean up all visible signs of oil.
2	Free liquid should be placed in closed drums.
3	Place solid material (soils, plant materials, et cetera) in drums.
4	Clean or remove all oil-contaminated vegetation. Wash and rinse all hard surfaces with a suitable solvent or cleaner.

*Continued on next page*

**Oil-Contaminated Asphalt and Concrete**

Step	Action
1	Make sure the area is well ventilated before you start to clean.
2	Recover liquid with a granular absorbent. Sweep it into piles with a broom, and then pick up with a shovel and dispose of material in a closed drum.
3	Wash and rinse hard surface twice, picking up the liquid with absorbent after each step.

**Spills Within a Vault**

If the equipment is known to contain PCBs, contact the Environmental Services 24-Hour Spill Pager (see *Table 2*).

- Vault spills are usually contained within the vault and may not pose an immediate environmental risk. Contact Environmental Services for assistance and guidance.
- Assess the quantity of oil present. Is it just a sheen on the water or is there a significant amount of oil?

**To Clean Up an Oil Sheen**

Step	Action
1	Place absorbent pads on the surface.
2	Move the pads around and allow time for the oil to be absorbed.
3	Remove the pads and place in a plastic bag.

**To Clean Up a Large Amount of Oil**

Step	Action
1	Environmental Services should be called to respond to large spills that exceed the available resources of the crew.  Contact the Environmental Services 24-Hour Spill Pager (see <i>Table 2</i> ).
2	Typically, a vactor truck is requested to pump out the vault. See the Vactor Truck Waste Accumulation, Transport, and Disposal section of this standard.  Contact the Environmental Services 24-Hour Spill Pager (see <i>Table 2</i> ) for assistance in scheduling a vactor truck.

*Continued on next page*



## Cleanup Guidelines for Specific Circumstances, *Continued*

### Spills from Capacitors

Spills from capacitors at substations may contain PCBs. If the capacitor is not labeled as Non-PCB, assume it contains PCBs. Therefore, Environmental Services should be contacted to respond. Contact the Environmental Services 24-Hour Spill Pager (see *Table 2*).

For small spills from capacitors not at substations:

Step	Action
1	Disconnect the capacitor.
2	Allow five minutes to lapse before short circuiting from terminal to terminal with either aluminum or copper tie wire, #14 or larger. <i>NOTE:</i> Each capacitor must be shorted individually. Capacitors cannot be strung together when applying shorts.
3	Inspect for any leakage of fluid or oil.
4	Place capacitors that are cracked, ruptured, or leaking in heavy-duty plastic bags.
5	Place the bagged capacitor in a drum with one pail of absorbent granules per capacitor in the bottom and clamp the lid securely.
6	Remove contaminated gravel, sand, and soil and place it in a drum.

### Spills from System Oil

Spills from system oil from natural gas pipelines may contain PCBs. Contact Environmental Services immediately if there is a spill from system oil. See Standard 0150.3275 for more information on system oil.

### Spills Affecting Water

Contact the Environmental Services 24-Hour Spill Pager (see *Table 2*) immediately.

**Figure 2**

Oil retrieval from a catch basin

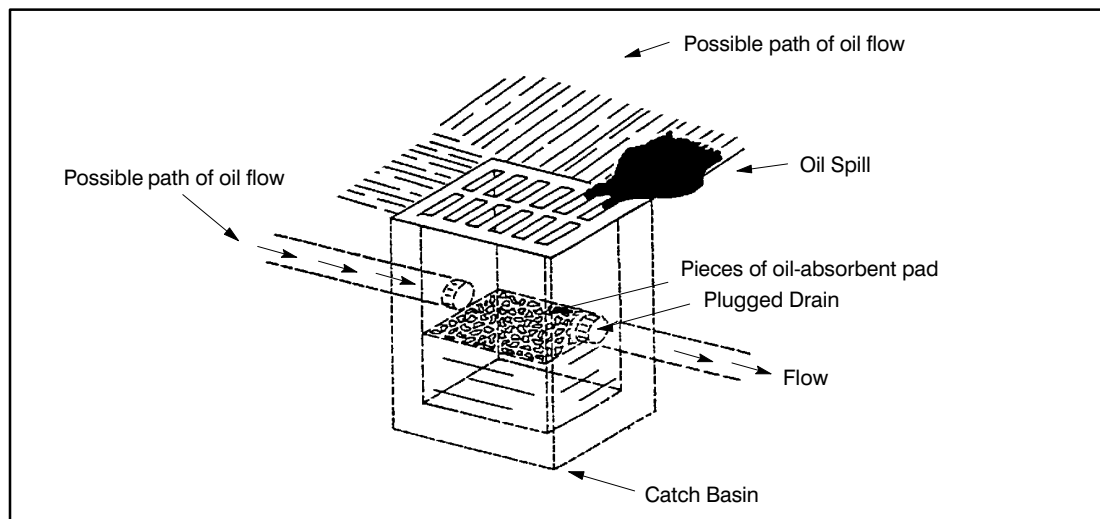

*Continued on next page*

## Large Spill

Figure 3 shows containment for a large spill into a stream. The boom is used to trap oil on the surface of the water and prevent it from flowing downstream. It is laid on the surface of the water and anchored at each end with a wood stake or rocks.

Figure 3

Large volume of oil in a stream

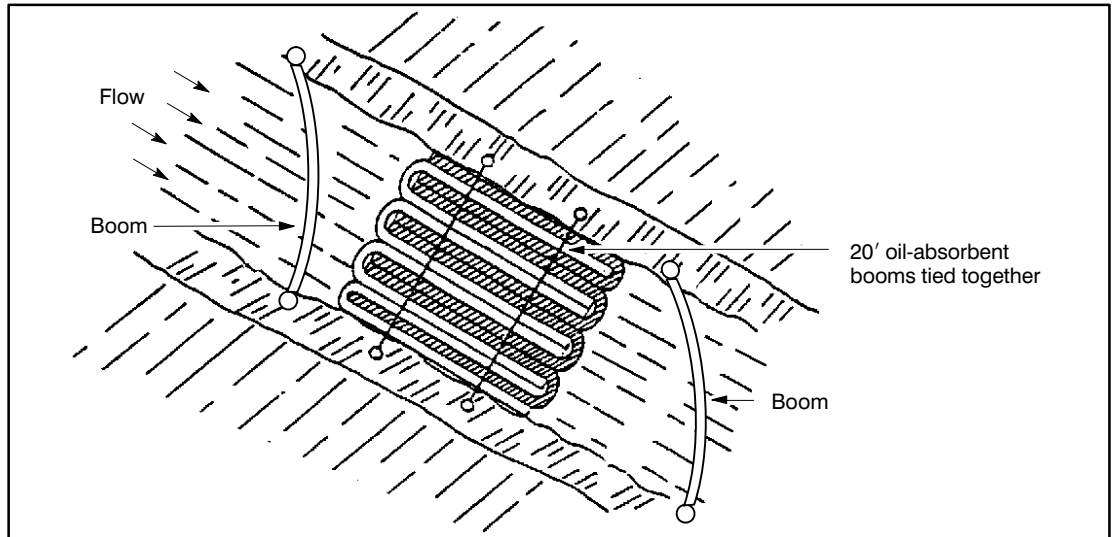

## Use Wire Mesh

If a boom is not available, wire mesh may be used to build a net across a drainage ditch. Wood stakes are used to anchor the mesh in place. The absorbent material is placed on the surface of the water on the upstream side of the mesh.

Figure 4

Using wire mesh as a boom

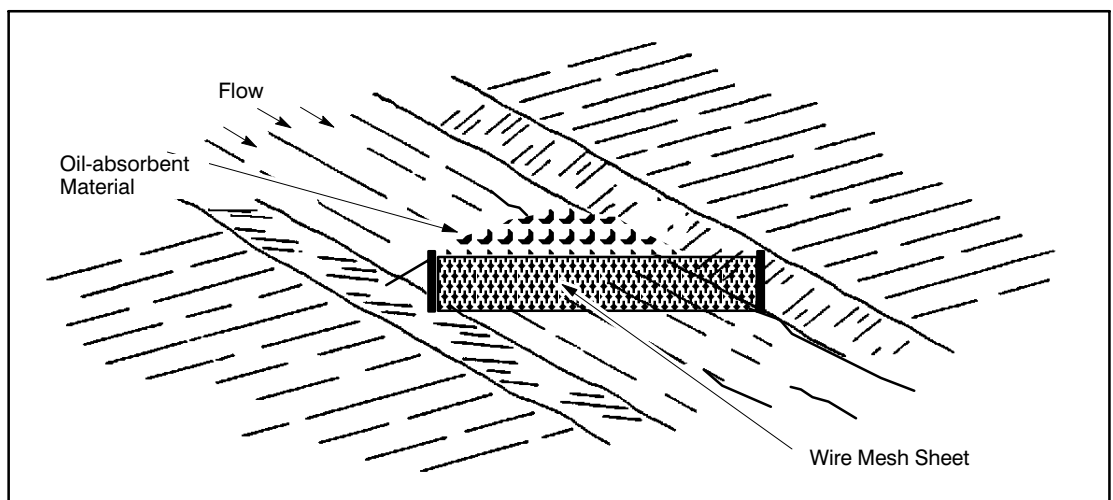

Continued on next page

Cleanup Guidelines for Specific Circumstances, *Continued*

**Small Spill**

One end of the boom should be anchored farther downstream than the other, forming a “V” close to the downstream end. The oil-absorbent materials or the contents of a boom are then used to collect and remove the oil from the surface of the water. Using three or more booms or dams is recommended.

**Figure 5** Small volume of oil spillage

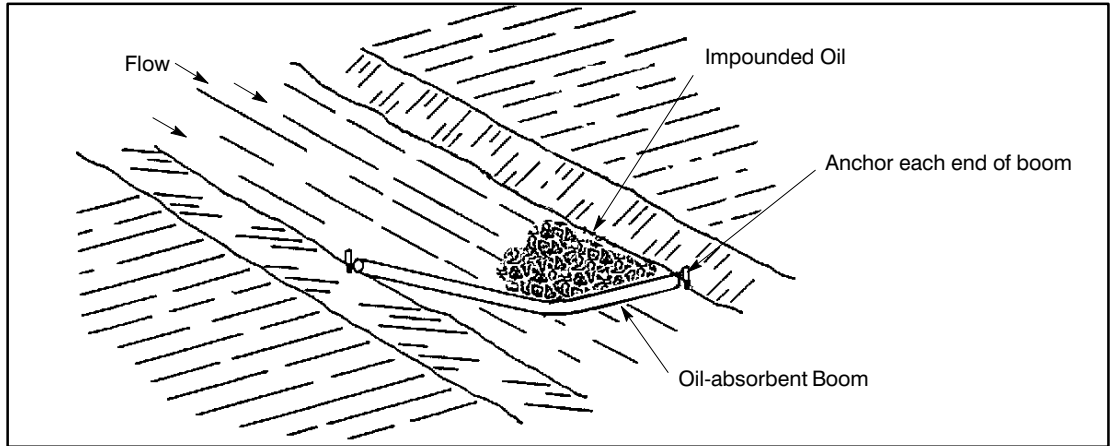

**Use Plastic Sheeting**

It is important to keep the oil from seeping into the ground. Polyethylene sheeting is used to line a trench or hole that has been dug for the purpose of collecting spilled oil.

**Figure 6** Dam containment system

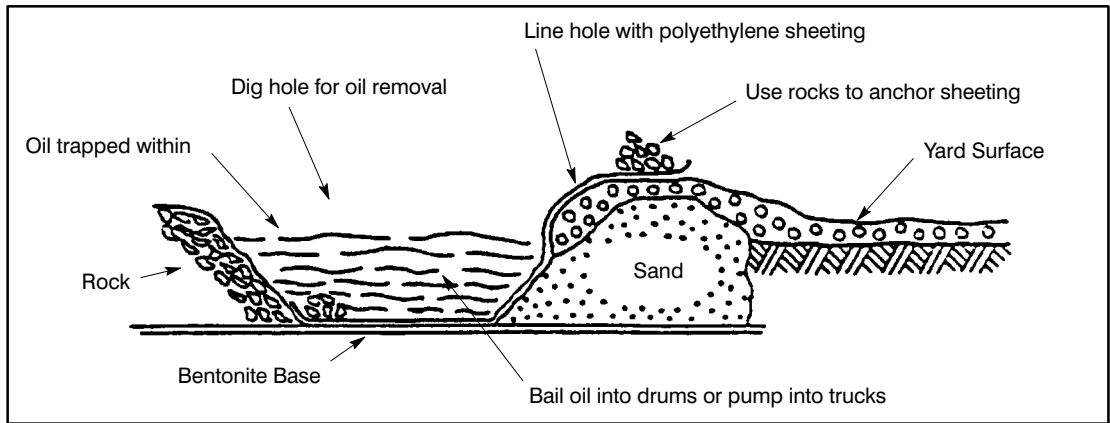

*Continued on next page*

**Dig a Hole**

Figure 7 shows how a hole can be dug and lined to hold spilled oil until it can be removed.

**Figure 7**

Hole lined for oil containment

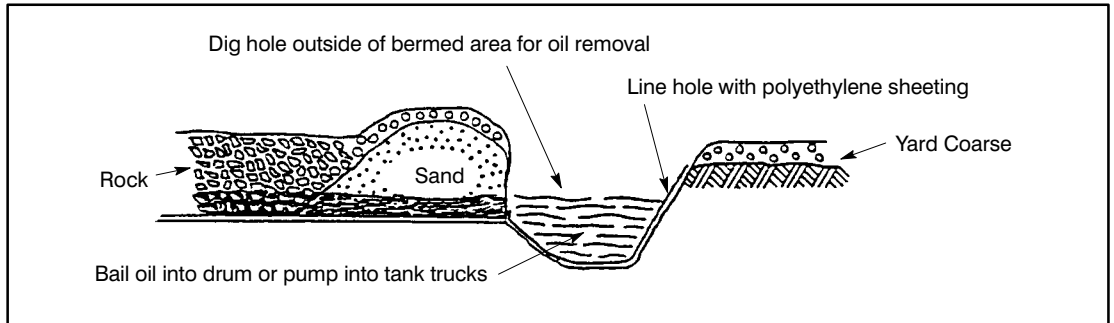

**Use a Rock**

Figure 8 shows how rock is used to secure the lining.

**Figure 8**

Lining secured with rocks

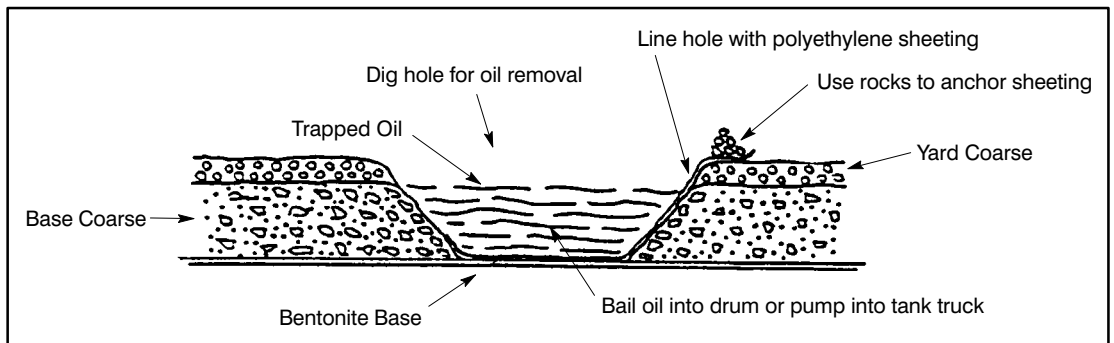

**Dam with Through-Pipe**

If oil has spilled into a drainage ditch, a dam with a through-pipe connection may be used to contain the oil spill, but permit water to pass.

**Figure 9**

Dam with a through-pipe

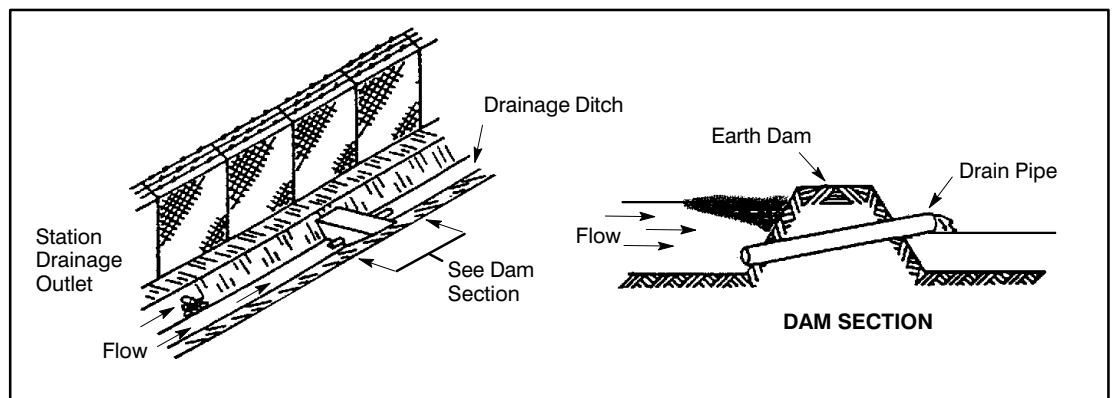

**Decontamination of Equipment**

All contaminated equipment, including hand tools, power tools, earthmoving equipment, vehicles, et cetera that become contaminated with oil containing PCBs in known or assumed concentrations of 1 ppm or greater must be decontaminated before leaving the spill site.

- Vehicles, electrical equipment, and tools can be cleaned by wiping the surface two times with clean rags and a detergent solution.
- Prevent or collect drips of used solvents and detergents.
- Do not dump used solvents and detergents on the ground. Collect the waste in drums.
- When finished, PPE should be removed before leaving the decontamination area and collected properly in containers. Remove boot covers first, then overalls, and then gloves last.
- Respirators should be cleaned using the manufacturer’s instructions.
- Hands and other exposed skin should be washed thoroughly before eating or drinking.
- For equipment that comes in contact with mineral oil with 50 ppm or more, PCBs must be decontaminated and then quarantined until chemical analysis can prove that same areas (on the equipment) are free of PCBs. Call Environmental Services for assistance.

**Vactor Truck Waste Accumulation, Transport, and Disposal**

Vactor trucks are available for removing accumulated liquids at spill sites and for cleaning storm drains, vaults, and catch basins. Wastes picked up by vactor trucks are typically taken to PSE’s South King Waste Management Facility (WMF), where the mixture of oil, water, and solids is discharged at the wastewater treatment facility. If the recovered spill material contains a large volume of solids, it may be transported to a PSE-approved commercial disposal facility instead of to the WMF. Contact Environmental Services for guidance.

**Vactor Truck Guidelines**

A vactor truck must not be used for any equipment that contains PCBs of 50 ppm or greater, unless under the direction of Environmental Services.

- For spills known to contain PCBs, contact the Environmental Services 24-Hour Spill Pager for assistance.
- For spills where the PCB content of the spill is initially unknown, the vactor truck operator must verify with the Foreman the PCB content of the oil that was released prior to beginning work. Contact the Environmental Services 24-Hour Spill Pager (see *Table 2*) for assistance.

**Vactor Truck Transport Procedure**

Step	Action
1	The vactor truck operator must obtain a copy of the draft Spill Report Form (Form 1184) from the Crew Foreman to document the load.
2	The vactor truck operator contacts the WMF by phone and receives approval to discharge loads. The vactor truck operator must ensure that the PCB concentration of the source oil is known prior to disposing of any vactor truck load.

*Continued on next page*

Step	Action
3	The vactor truck operator transports the load to the WMF where it is discharged in compliance with discharge requirements set forth in the WMF Operations and Maintenance Manual.
4	The vactor truck operator logs the required information in the vactor truck logbook.
5	The vactor truck operator provides a copy of the Spill Report Form (Form 1184) to WMF personnel.
6	The WMF personnel process the discharged load in accordance with the WMF Operations and Maintenance Manual.

**Spill Waste and Equipment Accumulation and Transport**

If the spill volume is small, materials collected from the spill should be placed in drums and transported to the nearest Service Center. Refer to Standard 0150.3125 for guidance.

**Record Keeping**

This section sets forth the records required when a cleanup of an oil spill has been performed.

**Industrial Injury & Illness Report (Form 3892)**

If there is an injury or illness, the Supervisor shall complete an Industrial Injury & Illness Report (Form 3892) and submit it to the Safety Department.

**Spill Report Form (Form 1184)**

The Crew Foreman should prepare a draft Spill Report Form (Form 1184) and submit it to the Supervisor, who finalizes the report and submits it to Environmental Services. If Environmental Services responds to the spill, they will complete their own Spill Report Form (Form 1184).

- The white copy of the spill report is submitted to Environmental Services at the South King Waste Management Facility.
- The canary copy is included with any samples sent to a laboratory.
- The pink copy is maintained at the satellite Service Center in the on-site files.
- The goldenrod copy should stay with the spill waste (taken by the vactor truck driver or kept with the containers of spill waste).

Spill reports need to include the information on the status of corrective actions and any plans for follow-up should be described in detail.

*Continued on next page*

## Record Keeping, *Continued*

### Decontamination Records Maintenance for Spills with Concentrations of 50 ppm or Greater of PCBs

For cleanups of spills of oil with 50 ppm or greater of PCBs, records of decontamination must be maintained for five years, including:

- Identification of the source of the spill (e.g., type of equipment).
- Estimated or actual date and time of the spill occurrence.
- The date and time cleanup was completed or terminated. If cleanup was delayed by emergency or adverse weather, include the nature and duration of the delay.
- A brief description of the spill location and the nature of the materials contaminated.
- Precleanup sampling data used to establish the spill boundaries, if required, because of insufficient visible traces and a brief description of the sampling methodology used to establish the spill boundaries.
- A brief description of the solid surfaces cleaned.
- Approximate depth of soil excavation and the amount of soil removed.
- A signed certification statement stating that the cleanup requirements have been met and that the information contained in the record is true.
- For spills in nonrestricted access areas, post cleanup verification sampling data, and if not otherwise apparent from the documentation, a brief description of the sampling methodology and analytical techniques used.

### Analytical Results

- Analytical results of samples obtained from oil-filled equipment are entered into the SAP database. A hard copy is maintained in the Environmental Services files at the Waste Management Facility.
- Analytical results of samples obtained to characterize soil conditions in the spill area are filed with the Spill Report Form (Form 1184).
- Analytical results of samples obtained to characterize waste are filed with other waste records (profiles, manifests, et cetera).

### Shipping Records

Record keeping to track the equipment includes:

- **For equipment that is less than 50 ppm of PCBs** – the analytical report from SAP showing the equipment’s PCB concentration and a shipping record.
- **For PCB capacitors and equipment that is 50 ppm or greater of PCBs** – the analytical report from SAP showing the equipment’s PCB concentration and a WMF Shipping Document (Form 1754), which acts as an internal shipping manifest.
- Record keeping to track spill waste shipments including bills of lading.
- Hazardous/TSCA waste manifests
- Certificates of disposal for shipments of PCB wastes



## References

The following Puget Sound Energy documents apply to this standard.

0150.3125	Temporary Storage of PCB Items
0150.3275	Collecting, Managing, and Disposing of Liquids from Natural Gas Equipment

---

## Forms

1184	Spill Report Form
1257	Chain of Custody Report
1754	WMF Shipping Document
3892	Industrial Injury & Illness Report

---

Employee Safety & Health Program

---

## Sources

### 40 CFR

112	Oil Pollution Prevention
761	Polychlorinated biphenyls (PCBs) Manufacturing, Processing, Distribution in Commerce, and Use Prohibitions

# Oil Sampling Procedures for Distribution Transformers and Oil-Filled Equipment

0150.3150

## Scope

This standard covers oil sampling procedures for distribution transformers and oil-filled equipment. For substation equipment, see Standard 8625.1070.

## Background

Sampling of equipment is sometimes required to determine the PCB concentration of oil to profile a waste or to satisfy a customer's request, for example, during an environmental site assessment or property transfer. All sampling should be done by Environmental Services personnel. When that is not possible, the Environmental Services Department should be called for guidance.

## In This Standard

These topics are covered in this standard:

Topic	See Page
Do Not Test for PCBs	2
Responsibilities	2
Safety	3
Personal Protective Equipment	3
First Aid	4
Tools, Materials, and Equipment	5
Ways to Take an Oil Sample	6
Sampling Methods	7
Impalement Method	8
Pressure Relief Valve Method	10
Bay-O-Net Method	11
Valve Method	12
Cleanup	14
Decontamination of Nondisposable Equipment	14
Shipping the Sample	15
Shipping DGA Analysis	15
Record Keeping	15

### WARNING!

These procedures comply with the Environmental Protection Agency and the OSHA and NIOSH guidelines that protect the environment and health of Puget Sound Energy workers. Federal regulations require a yearly review of this practice.

## Do Not Test for PCBs

Each piece of electrical equipment can contain a different amount of PCBs. Testing for PCB concentration is not necessary if:

- The nameplate states that the equipment has less than 1 ppm PCBs. Often the manufacturer will specify on the equipment nameplate whether or not the concentration of PCBs contained in the dielectric fluid is less than 1.0 ppm non-PCB.
- The equipment has already been tested and the analysis has been recorded with a date later than 1986. A search by serial number (from the manufacturer's nameplate), Company ID number or Grid Number can be used to query PSE's SAP database to determine if sample data already exists for the equipment.
- The specified regulatory assumptions (40 CFR 761.2) can be used to determine the approximate concentration of PCBs found in the equipment.
- The device is a capacitor or ballast. Capacitors and ballasts are either labeled by the manufacturer as non-PCB or they are assumed to be greater than 500 ppm PCB and are not sampled.

**NOTE:** Analyses for PCB concentrations that were conducted prior to 1986 are no longer honored, including pre-1986 results that are shown on metal tags attached to equipment, paper or database records, yellow stickers (less than 50 ppm PCBs) and blue stickers (non-PCB). New analyses must be performed to properly document the concentrations of PCBs in the oil.

---

### Contacting Environmental Services Before and After Business Hours

If the question occurs during business hours, contact the Environmental Services Department at (253) 437-6789 or 82-6789 (from the PSE phone system) to determine the probable PCB concentration. If the question occurs after normal business hours, the Dispatcher or System Operations should page individual Environmental Services personnel at (360) 340-3718 for assistance in looking up the PCB content in SAP.

---

## Responsibilities

### Environmental Services

Sampling should typically be done by Environmental Services personnel.

### Line Work Crews

Line/work crews are responsible for sampling only when Environmental Services personnel are unavailable. For these special occasions, they should contact Environmental Services for guidance.

### South King Waste Management Facility

All samples shall be sent to South King Waste Management Facility for processing by Environmental Services.

## Safety

Oil sampling performed on energized systems shall be done only with hotstick tools designed especially for the job.

Oil sampling procedure for energized systems shall *not* be performed on cast iron or fiberglass transformers.

**⚠ DANGER!**

If you choose to take an oil sample while the transformer is energized, use insulated tools.

## WAC Rule

Employees and conducting objects shall not come within the minimum distances of energized lines or conductors according to Table 1 in WAC 296-45-325.

## PCB Holding Area

Waste material and oil must be placed in the Service Center’s designated PCB holding area. Check with the Storekeeper to make sure you place the waste appropriately.

## Personal Protective Equipment

Personal protective equipment is to be worn during all phases of oil sampling.

Disposable plastic gloves and a face shield, and, when necessary, disposable coveralls and boots shall be worn whenever you take oil samples.

When solvents are used in a confined area, or when air quality is questionable, use a respirator.

## For Oil Sampling

This chart illustrates the kind of personal protective equipment you should wear during the oil sampling process.

Personal Protective Equipment	Type	MID	Examples of Appropriate Use
Eye Protection	Safety glasses with side shields	6827000 6827101	Collecting oil samples for gas chromatograph analyses.
	Goggles	6827300	
	Goggles	6827300	
Eye Protection	Face shield	6829000	Any time splash could occur.
		non-hard hat	
		6830000 hat-mounted	
		6888000	
Gloves	Nitrile – protect up to 1 hour	6858000	Gloves are required for hand contact with PCBs: Oils, leaking/contaminated equipment, soil, surfaces.

A complete list of personal protective clothing and equipment is in Standard 0150.3100.

## First Aid

If eyes, skin, or clothing come in contact with PCBs, or if they are ingested or inhaled, follow these abbreviated first aid treatments. More complete treatments are in Standard 0150.3100.

---

## Eye Contact

Flush eyes with water or eye irrigation solution for at least 15 minutes.

---

## Skin Contact

Clean skin immediately with soap and water. If soap and water aren't available, use waterless hand cleaner.

---

## Clothing Contact

Remove contaminated clothing as soon as possible.

---

## Ingesting

Employee is to be taken to a hospital immediately.

---

## Inhaling

If nausea, breathing difficulty or dizziness occur, employee is to be taken to a hospital immediately.

---

# Oil Sampling Procedures for Distribution Transformers and Oil-Filled Equipment

**0150.3150**

## Tools, Materials, and Equipment

These tools and materials are required for oil sampling operations.

Labels/Forms	MID	Used for
Transformer Inspection Form	None	All oil sampling methods
EPA yellow PCB Mark M <sub>L</sub> label	3849100	Containers greater than 50 ppm or transformers 500 or greater ppm
Chain of Custody Report Dissolved Gas Analysis	F483.65 (printing form)	Shipping the DGA sample
Chain of Custody Report PCB/TPH Analysis	F483.55 (printing form)	Shipping the sample
Chain of Custody Report Emergency Analysis	F483.50 (printing form)	Shipping the sample for a rush analysis
Tools	MID	Used for
Hammer	7355100	Impalement method
Battery Operated Drill Motor, 3/8" Drive, Slow Speed	None	Impalement method
Drill Bit, Split Fluted 9/32" w/ Magnetized Collet, 1/16" Depth, OH	7222002	Impalement method
5/16" Socket, 3/8" Drive	None – Available from JACO Construction Co.	Impalement method
Insulated Tools	MID	Used for
Hotstick equipped with disposable syringe and hose applicator	None – Available from JACO Construction Co.	Any energized oil sampling
Hotstick modified for drill and drill bit	None – Available from JACO Construction Co.	Any energized oil sampling
Shotgun	7351100	Any energized oil sampling

*Continued on next page*

## Tools, Materials, and Equipment, *Continued*

Miscellaneous	MID	Used for
Waterproof Marker, Printing and Stationery #383-1	None	All oil sampling methods
Plastic Bags	7220000	All oil sampling methods
Rags	7474500	All oil sampling methods
Galvanized Zinc Paint	4652700	All oil sampling methods
RTV Sealant	7808000	All oil sampling methods
Caulking Gun	7344700	All oil sampling methods
Oil Sampling Kit	7408600	All oil sampling methods

## Ways to Take an Oil Sample

There are three different ways to take an oil sample from a transformer. Which way you choose depends on the type of transformer.

Oil-filled switches and other equipment may be sampled using Bay-O-Net fuses, or pressure relief valves, or the valve method.

The valve method is used for dissolved gas analysis.

If the equipment is . . .	See section for . . .
Overhead transformer without pressure relief valve or filler plug	Impalement method
Overhead transformer with pressure relief valve or filler plug	Pressure Relief Valve method
Padmount and total underground transformer	Bay-O-Net method
Oil-filled switches and equipment	Bay-O-Net method, Pressure Relief Valve method, Valve method

## Before You Begin

These preparatory steps apply to all methods of taking oil samples.

- Visually inspect each work area and plan procedures for containing transformer oil if a spill occurs.
- Inspect the materials, equipment, and electrical connections on and around the transformer.
- Check the ground connections to the transformer case, pole ground, and neutral.
- If the oil level is low in a switch, do not test it.

Notify the proper supervisor of problems or potential problems which should be corrected before work begins.



## Sampling Methods

These are the procedures for the four methods to take oil samples from a distribution transformer:

- Impalement
- Pressure relief valve
- Bay-O-Net
- Valve

**⚠ DANGER!**

If you choose to take an oil sample while the transformer is energized, use insulated tools.

Figure 1

Oil sampling areas

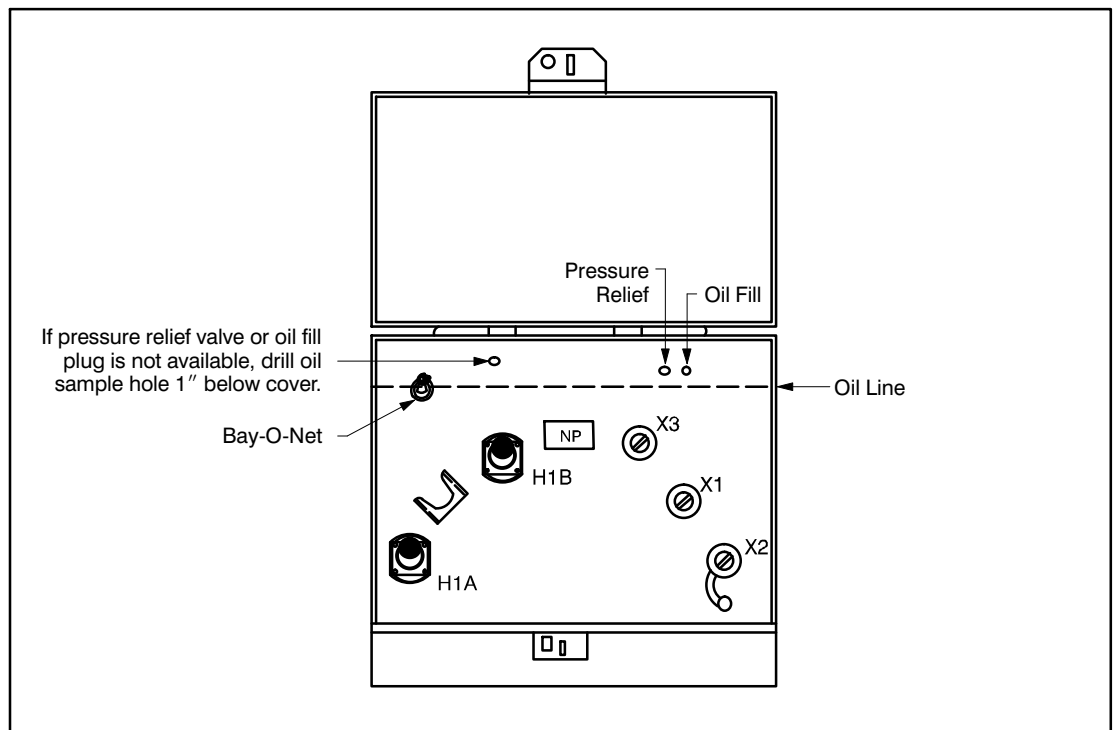

## Impalement Method

This section tells you how to use the impalement method to take oil samples from overhead transformers without pressure relief valves or filler plugs.

Figure 2

Impalement method

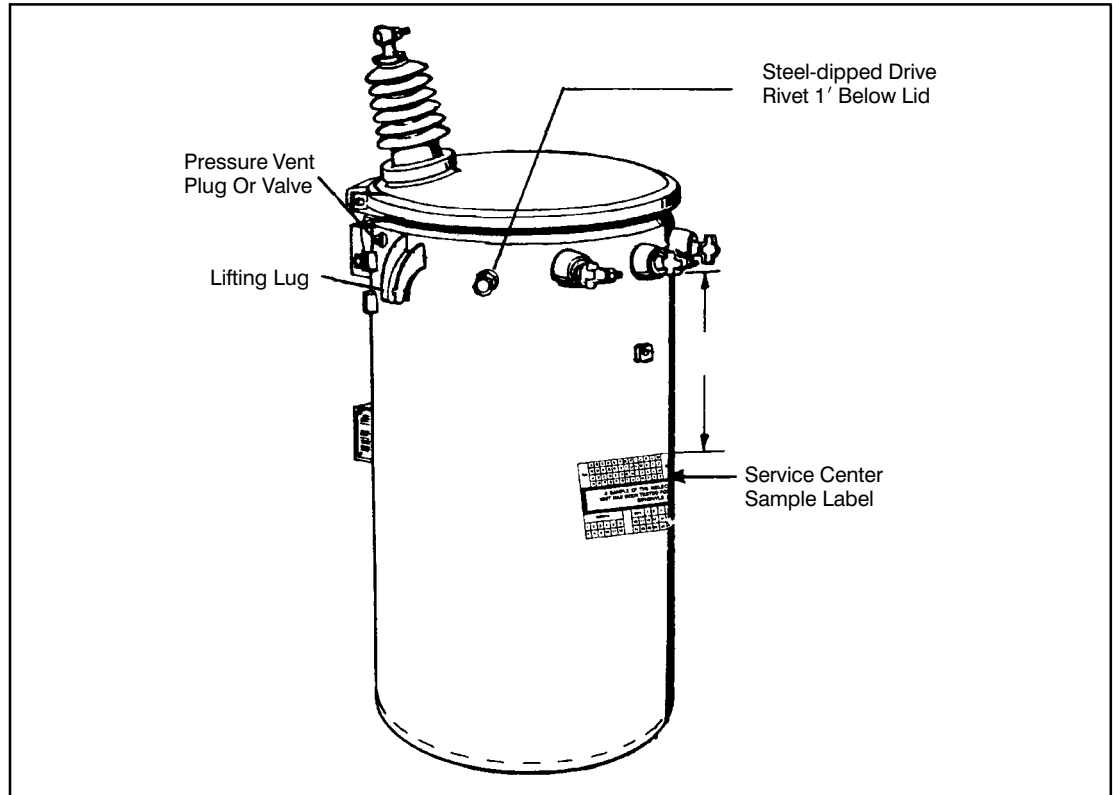

*Continued on next page*

# Oil Sampling Procedures for Distribution Transformers and Oil-Filled Equipment

**0150.3150**

## Select Oil Sampling Point

Select a location for the oil sample hole above the oil line.

Step	Action	Procedure
1	Select, mark, and clean oil sampling location.	Measure 1/2 inch to 1 inch below the cover or top, between the secondary neutral bushing and the lifting lug, and mark the location.  Use denatured alcohol to remove dirt and contamination from the location.
2	Drill the oil sampling hole.	Use a slow-speed drill with a split fluted bit to slowly drill the transformer case at the marked location until the collet touches the case.  The collet will act as a stop, keeping the drill from going all the way through.  <b>NOTE:</b> Drill shavings caught inside the magnetized collet should be cleaned out frequently with a small wire.
3	Drive the punch through the case.	Use an impalement tool and a hammer to drive the punch through the wall of the transformer case until the collar touches the case.

## Drawing the Oil Sample

These next steps tell you how to draw the sample, clear the tube, and clean the area. Select a location for the oil sample hole above the oil line.

Step	Action	Procedure
1	Draw oil sample.	Use a disposable syringe to insert the hose into the hole and draw out the oil sample.  <b>NOTE:</b> The syringe plunger should be completely in <i>before</i> drawing out the sample.
2	Clear tubing of air.	Tip the syringe plunger end down so the air is toward the tubing end of the syringe, then move the plunger forward until most of the air is out of the syringe.
3	Wipe the area.	Use denatured alcohol to wipe the drilling area clean of any oily residue.

*Continued on next page*

## Impalement Method, *Continued*

### Finishing the Operation

The next steps tell you how to plug and seal the hole.

Step	Action	Procedure
1	Plug the hole.	Place a dipped steel rivet into sampling hole and strike the drive pin with a hammer.
2	Seal the hole.	Apply RTV sealant around the drive rivet. Be careful to completely cover the rivet and any surrounding area where paint may have been chipped off.
3	Check for leaks.	Check for leaks around the newly installed rivet.

See the Cleanup and Applying Labels section in this standard to finish operation.

---

## Pressure Relief Valve Method

This section tells you how to use the pressure relief valves or filler plugs to take an oil sample.

Use this method for overhead transformers with pressure relief valves or filler plugs.

Step	Action	Procedure
1	Clean the area.	Use denatured alcohol to remove dirt and contamination from the location.
2	Remove valve.	Remove the valve or plug from the transformer case
3	Draw oil sample.	Use a disposable syringe to insert the hose into the hole and draw out the oil sample.  <i>NOTE:</i> The syringe plunger should be completely in <b><i>before</i></b> drawing out the sample.
4	Clean the area.	Use denatured alcohol to wipe the drilling area clean of any oily residue.
5	Replace valve.	Replace the valve or plug and check for leaks.

See the Cleanup and Applying Labels section of this standard to finish operation.

---

## Bay-O-Net Method

This method is to be used for taking oil samples from padmount and total underground transformers.

### If TUT is Energized

De-energize total underground transformer with an elbow before removing the Bay-O-Net fuse.

**⚠ WARNING!**

Do *not* use the drill method on these types of transformers, as screws installed in them tend to leak.

Step	Action	Procedure
1	Clean the area.	Use denatured alcohol to remove dirt and contamination around the Bay-O-Net fuse.
2	Lay plastic sheet.	Lay a piece of plastic sheeting at the bottom of the transformer below the Bay-O-Net fuse opening to catch oil drippings.
3	Take oil sample with Bay-O-Net fuse.  <i>OR see Step 4.</i>	Holding a sample bottle below the Bay-O-Net opening, pull the Bay-O-Net fuse out of the transformer and let the oil drip off the fuse into the sample bottle.  The Bay-O-Net may have to be reinstalled and pulled out several times to get an adequate sample.
4	Take oil sample with pipette and tube.	A disposable dropping pipette with an 18-inch propylene tube can also be used to draw an oil sample.  Remove the Bay-O-Net fuse and insert the tube into the Bay-O-Net tank opening.  Hold the tube with the bulb pointed downward and squeeze the bulb to draw oil into the pipette. Several draws may be required to get an adequate sample.
5	Fill bottle half full and clean drippings.	When the sample bottle is half full, wipe off all oil from the outside of the tank and any drippings caught on the plastic sheeting.  Use a rag dampened with denatured alcohol.

See the Cleanup and Applying Labels section of this standard to finish operation.

## Valve Method

This method is to be used for taking oil samples from padmount oil-filled switches and equipment.

### Prepare the Area

These first steps tell you how to prepare the area.

Step	Action	Procedure
1	Clean the area.	Use denatured alcohol to remove dirt and contamination around the valve.
2	Remove the switch valve plug.	Slightly open the valve to flush out any stagnant oil.
3	Attach bushing adapter.	If a sampling cock is already installed, use that instead.
4	Attach brass connector to adapter.	Check for tightness.
5	Allow one gallon of oil to flow into waste oil container.	This ensures the sample will be obtained from the main section switch.  If air bubbles, sludge, or sediment are in this oil, continue flushing until you see a steady flow of clear oil.
6	Close the drain valve.	---

**Figure 3**

Valve method – dissolved gas analysis

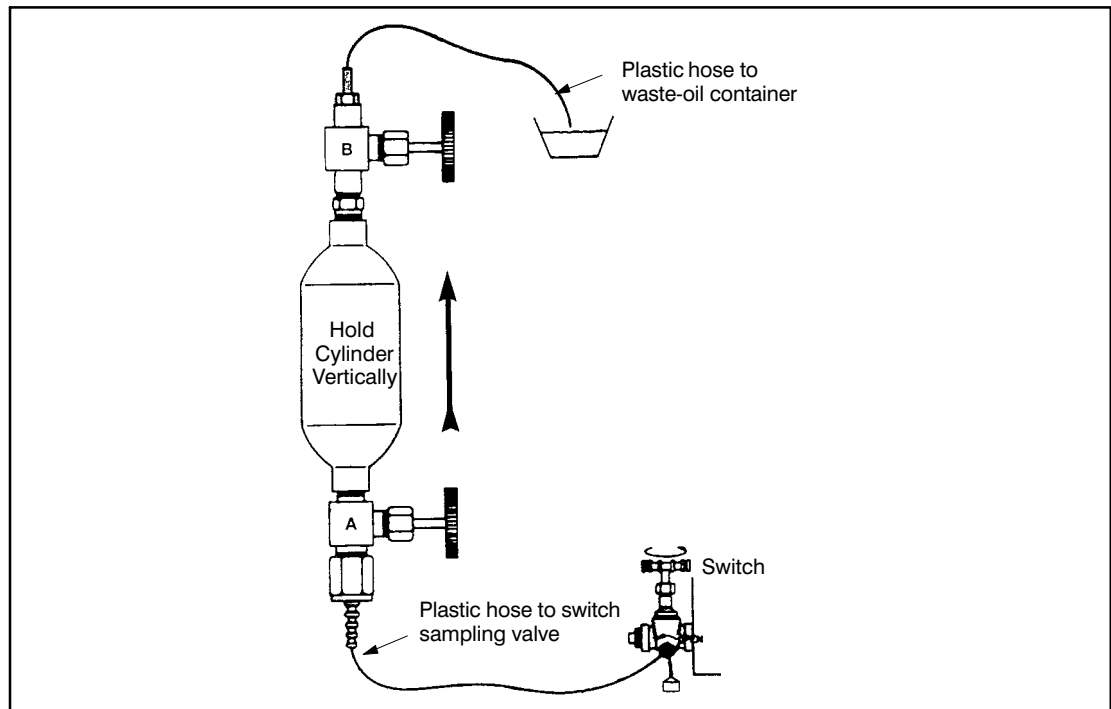

*Continued on next page*

# Oil Sampling Procedures for Distribution Transformers and Oil-Filled Equipment

0150.3150

## Attach Sample Fittings

These steps tell you how to attach the sample fittings.

Step	Action	Procedure
1	Connect sample cylinder to large plastic tube.	Use the serrated brass fitting.
2	Connect small plastic tube to the other end of the cylinder.	Use the Luer-Lok fitting.
3	Hold the cylinder vertically with the large plastic tube on the bottom.	A. Open the valve at the switch. B. Open the bottom cylinder valve. C. Open the upper cylinder valve.

## Take the Oil Sample

These steps tell you how to take the oil sample and replace the plug.

Step	Action	Procedure
1	Allow one quart to flow into the waste oil container.	If air bubbles are seen in the plastic tube, tap or shake the tube lightly. Flush with oil until the flow out of the cylinder is free of bubbles.
2	Close the cylinder.	A. Close the upper cylinder valve. B. Close the bottom cylinder valve. C. Close the switch valve.
3	Disconnect the plastic tubes.	Check the cylinder for air bubbles by shaking it and listening for oil movement. If there is there movement, reconnect the cylinder and flush more oil through until the cylinder is completely filled.
4	Remove bushing adapter and replace plug.	

See the Cleanup and Applying Labels section of this standard to finish operation.



## Cleanup

Cleanup after you take the oil sample is the same for all methods.

Step	Action
1	Clean up all visible signs of oil.
2	Place rags and other material used to clean up oil in a plastic bag. Dispose of it in the designated PCB holding area located at the Service Center.
3	Tools shall be cleaned with alcohol.

## Decontamination of Nondisposable Equipment

Nondisposable equipment means hand tools, power tools, earthmoving equipment, vehicles, et cetera that become contaminated with oil containing PCBs in known or assumed concentrations of 1 ppm or greater.

All contaminated equipment, including vehicles, should be decontaminated before leaving the spill site.

Equipment	Procedure
Vehicles	Wipe two times with clean rags and a detergent solution.
Electrical equipment and tools	Wipe two times with clean rags and a solvent.

## Solvents and Detergents

- Prevent or collect drips of used solvents and detergents.
- Do not dump used solvents and detergents on the ground.
- Place used solvents and detergents in properly labeled drums and send to General Stores for appropriate disposal.

## Personal Protective Equipment

Personal protective equipment should be removed before leaving the decontamination area and disposed of properly in containers.

- Respirators should be cleaned using the manufacturer's instructions.
- Hands and other exposed skin should be washed thoroughly before eating or drinking.

Remove personal protective equipment *in this order*:

- Boot covers
- Overalls
- Gloves

## Shipping the Sample

Ship samples for PCB analysis to the South King Waste Management Facility, SKC-WMF.

- Styrofoam mailers, each of which holds 20 samples, are available from Environmental Services for this purpose.
- If a Styrofoam mailer is not available, wrap the sample vials in absorbent pads to cushion them and place them in a cardboard box.

---

## Shipping DGA Analysis

All Dissolved Gas Analysis is sent directly to Doble in Massachusetts.

---

## Record Keeping

Analytical results of samples obtained from oil-filled equipment are entered into the SAP database. A hard copy is maintained in the Environmental Services Department files at the Waste Management Facility.

---

## References

The following Puget Sound Energy documents apply to this standard:

- |           |   |
|-----------|---|
| 0150.3100 | Cleanup of Oil Spills                                       |
| 8625.1070 | Oil-Sampling Procedures for Oil-Filled Substation Equipment |

---

## Sources

- |        |          |  |
|--------|----------|--|
| 40 CFR | Part 112 | Oil Pollution Prevention   |
|        | Part 761 | Polychlorinated Biphenyls (PCBs) Manufacturing, Processing, Distribution in Commerce, and Use Prohibitions |

- 
- |     |            |                                    |
|-----|------------|------------------------------------|
| WAC | 296-45-325 | Working on or Near Energized Parts |
|-----|------------|------------------------------------|

A placard with the following wording shall be attached to locked drainage valves for containment areas.

**NOTE**

**THIS CONTAINMENT DRAIN VALVE NORMALLY LOCKED IN THE CLOSED POSITION**

**DRAINING PROCEDURE:**

1. Check Diked Containment Area for presence of oil.
2. If no oil is detected, unlock and open valve.
3. Close valve and lock when draining is completed.
4. If oil is detected in the Diked Containment Area, refer to the Spill Prevention, Control, and Countermeasure Plan (SPCC Plan) for response procedures and notifications. **DO NOT** open valve.



***APPENDIX C***  
***MAINTENANCE AND INSPECTION RECORDS***

---