

---

June 2011

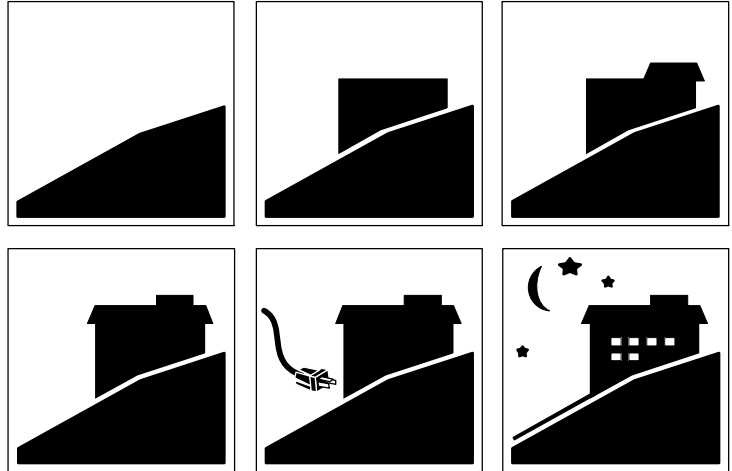

---

# Electric Service Handbook

Single-Family Residential Projects  
Permanent & Temporary Service

© 2011 by Puget Sound Energy

All rights reserved. No part of this book may be reproduced or transmitted in any form or by any means, electronic or mechanical, including photocopying, recording, or information storage and retrieval system, without permission from Puget Sound Energy (PSE).

**Puget Sound Energy**

Standards Department

P.O. Box 97034 EST-07W

Bellevue, WA 98009-9734

1-888-225-5773

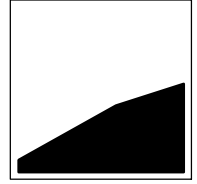

# Table of Contents

## Preface

What this handbook contains .....	vii
PSE's service availability .....	vii
Glossary of terms used in this handbook .....	vii
Codes, permits, and inspections .....	vii
Electrical service equipment inspection .....	viii
Reconnecting existing electric service after repair or replacement .....	viii
Scheduling .....	viii
Underground or overhead service? .....	viii
Underground service .....	viii
Overhead service .....	ix
Which type of electrical system is available in your area? .....	ix
Other electric service information .....	x
How to contact Puget Sound Energy .....	x
PSE's service providers .....	x
Overview: New Permanent and Temporary Electric Service Hookup to Existing PSE Power Facilities for Single-Family Residential Projects .....	xi

## Chapter 1: Steps to a Successful Permanent Electric Service Installation for Single-Family Residences

Definitions .....	1
Service installation responsibilities .....	1
Puget Sound Energy .....	1
Customer .....	1
Starting the installation process .....	2
Setting up an account or to order a new service .....	2
Will your project need engineering? .....	2
Choosing the right service size .....	3
Service voltages .....	3
Service sizes .....	3
Sizes less than 200 A .....	3
Determining an approved meter location .....	3
Customer-installed meter base/socket location .....	3
Locating other underground utilities .....	4
Locating existing underground utilities – <i>call before you dig!</i> .....	4
Coordinating utility trenching and construction .....	5

*Continued on next page*

Transformer locations ..... 5

Liquefied propane tanks: clearances from ignition source ..... 8

Outbuildings ..... 9

    Service line installation responsibilities for outbuildings ..... 9

Cost for service ..... 9

**Chapter 2: Permanent Underground Service**

Steps to a successful underground service installation ..... 11

Selecting a meter base/socket location ..... 12

    Multiple metered services ..... 12

Service line trenches ..... 12

    Trench and backfill requirements ..... 12

    Customer-installed service line conduit ..... 12

    Customer-installed service line conduit installation requirements ..... 13

Service entrance equipment ..... 13

    Installation requirements ..... 13

    Service entrance conduit size ..... 13

Permanent underground service for manufactured homes, 0–200 A ..... 16

    Service equipment installation ..... 16

    Meter base/socket requirements ..... 16

Remote metering (meter loop) for underground residential services ..... 17

    What is remote metering? ..... 17

    Requirements for single-family residential remote metering ..... 17

    400 A and larger panels ..... 18

    Meter post and pedestal locations ..... 18

**Chapter 3: Permanent Overhead Service**

Steps to a successful overhead service installation ..... 19

Selecting a meter base/socket location ..... 19

Clearance requirements ..... 20

    Service line ground clearance ..... 20

    Minimum clearances from structures, building openings, and gas meters ..... 21

Intermediate service pole ..... 22

Service mast ..... 22

    Service mast requirements ..... 22

    Height requirements ..... 22

    Additional mast supports (guy or brace) ..... 25

    Screw-in service knobs ..... 25

Service entrance equipment installation requirements ..... 25

Manufactured homes ..... 25

    Meter base/socket installation requirements for manufactured homes ..... 26

Customer-owned meter pole ..... 26

    Meter pole requirements ..... 26

    Installation requirements ..... 26

**Chapter 4: Primary Line Extensions**

Customer responsibility .....	29
Inspection/coordination .....	29
Site preparation .....	29
Customer-provided trench .....	30
Trench width .....	30
Trench excavating requirements .....	31
Trench and backfill requirements for electric .....	31
Trench and backfill requirements if a natural gas line is in the trench .....	32
Vaults .....	32
Vault excavation procedure .....	32
Vault location and access .....	34
Vault backfill material .....	34
Continuous conduit systems .....	35
Customer-supplied conduits .....	35
Terminating conduit at transformer .....	35

**Chapter 5: Meter Installation**

Service rating options .....	37
Responsibilities .....	37
Puget Sound Energy .....	37
Customer .....	37
Meter bases/sockets .....	37
General requirements .....	37
Meter base/socket location .....	38
Grounding requirements .....	38
Clearance requirements for meter installations .....	38
200 A services .....	40
Single-family residential .....	40
Underground .....	40
Overhead .....	40
Outbuildings (overhead or underground service) .....	40
400 A services .....	40
Underground .....	41
Overhead .....	41
Outbuildings (overhead or underground service) .....	41
400 A current transformer (CT) services .....	42
Services over 400 A .....	43

**Chapter 6: Temporary Services**

What this chapter contains .....	45
Definition .....	45
Obtaining your temporary service from existing power facilities .....	45
Temporary meter/base socket requirements .....	46
Scheduling .....	46
Customer charge for service .....	46
Temporary meter base/socket requirements .....	46
Temporary underground services .....	46
Meter location .....	46
Trenching and excavation requirements .....	47
Underground temporary service installation process .....	48
Temporary overhead services .....	50
Meter location .....	50
Service line path requirements .....	50
Clearance requirements .....	50
Overhead temporary service installation process .....	51

**Chapter 7: Disconnection and Modification of Service**

Disconnection of your meter .....	53
Modified services .....	53

<b>Glossary</b> .....	55
-----------------------	----

**List of Tables**

Table 1	Types of electric services .....	x
Table 2	Standard voltages for residential customers .....	3
Table 3	Service sizes available from PSE .....	3
Table 4	Color codes for locating utilities .....	4
Table 5	Clearances for padmount transformers .....	5
Table 6	Service line installation responsibilities .....	9
Table 7	CT enclosure dimensions (minimum) .....	43
Table 8	Example of overhead and underground modified service .....	54

## List of Figures

Figure 1	Underground facilities	ix
Figure 2	Overhead facilities	ix
Figure 3	Clearances for transformers	6
Figure 4	Clearances for transformers from structures	7
Figure 5	Minimum clearances from oil-filled equipment to LP, hazardous liquid, or fuel tanks	8
Figure 6	Minimum clearances from LP storage tanks to sources of ignition	9
Figure 7	Typical underground service from overhead power facilities	11
Figure 8	Two types of meter bases/sockets for permanent underground service	14
Figure 9	401–800 A service entrance equipment	15
Figure 10	Permanent underground service for manufactured homes, 0–200 A	17
Figure 11	Remote metering for underground residential services	18
Figure 12	Typical overhead service installation	20
Figure 13	Minimum overhead service line vertical clearances from ground level	21
Figure 14	Minimum clearances over other structures	21
Figure 15	Intermediate service pole location	22
Figure 16	Unguyed service masts	23
Figure 17	Guyed service masts	24
Figure 18	Permanent overhead meter pole installation	27
Figure 19	Typical joint utility trench with primary voltage cable on your private property	30
Figure 20	Padmount transformer vault excavation	33
Figure 21	Aboveground junction box vault excavation	33
Figure 22	Location of customer conduit in PSE vaults	34
Figure 23	Meter base/socket minimum clearances	39
Figure 24	Recessed meter installation clearances	39
Figure 25	Typical arrangement of service conductors for underground class 320 meter base/socket	41
Figure 26	Typical arrangement of service conductors for overhead class 320 meter base/socket	42
Figure 27	Instrument-rated (CT) meter bases/sockets	42
Figure 28	Single-phase CT mounting base	43
Figure 29	Trenching requirements for power stubout	47
Figure 30	Temporary underground service installation	49
Figure 31	Minimum clearance requirements upon installation	51
Figure 32	Temporary overhead service installation	52

## Back pocket

Excavation Requirements for Joint Utility Mainline Trench	Form 2809
Contractor Referral Request	Form 2811
Installation Requirements for Underground Services	Form 3061



---

# Preface

---



This handbook is your guide to Puget Sound Energy's (PSE) requirements for new, altered/modified, or temporary electric service for permanent single-family residential structures. We have also included additional requirements for electric service to outbuildings (barns, shops, pump houses, garages, etc.).

---

## What this handbook contains

In this handbook you will find answers to questions such as:

- What are the installation requirements for permanent and temporary underground and overhead service?
- How do I choose the right service size?
- What are the trenching requirements?
- How do I locate existing underground utilities before I dig?

## PSE's service availability

General boundaries for PSE's gas and electric service territory are available on **PSE.com**. A ***Customer Construction Services (CCS) Representative*** can help you to determine the closest available service line and can provide you with cost information for establishing new service.

## Glossary of terms used in this handbook

For your convenience, glossary words appear in bold italics throughout the text the first time they appear (e.g., ***meter pole***).

---

## Codes, permits, and inspections

This handbook should only be used as a guide. It does not cover all possible federal, state, or local code requirements. It is your responsibility to ensure that your project complies with the most recent issue of the National Electric Code (NEC) and any other federal, state, or local codes that may apply.

This handbook shall not be interpreted to conflict with the regulations of the State of Washington or other regulatory bodies having jurisdiction. PSE's metering requirements may be more stringent. Local codes and requirements related to the planned work should be addressed before any construction begins.

### Electrical service equipment inspection

Once your service equipment is installed, the State of Washington, or the city with jurisdiction over your area, requires that your installation pass an electrical inspection before PSE can energize your system.

**NOTE: It is your responsibility to request an electrical inspection.**

Electrical inspections for most areas in the PSE service territory are done by the State of Washington Department of Labor and Industries. However, electrical inspections are performed by city personnel in several jurisdictions. Please consult PSE.com, Permits and Inspections, for a list of the cities and current contact information.

---

### Reconnecting existing electric service after repair or replacement

All electrical equipment and wiring on the customer side of the meter (including meter base and service masts) are owned and maintained by the customer. Therefore, **you are responsible for any repair or replacement of storm-damaged or failed metering equipment.** If you must repair/replace equipment of this kind, your service may need to be de-energized or disconnected.

For more information, refer to *Chapter 7, Disconnection and Modification of Service* section of this handbook or contact your *CCS Representative* at **1-888-321-7779**.

---

### Scheduling

The time needed for engineering, scheduling, and construction of the work will vary depending upon the complexity of the job and the volume of work requested by PSE customers. Contact your *CCS Representative* at **1-888-321-7779** for current construction scheduling.

---

### Underground or overhead service?

The two types of permanent services are: underground and overhead. If none of the items in *Figures 1* or *2* exist in your area, or if you have questions, call **1-888-321-7779** and a *CCS Representative* will be glad to assist you.

### Underground service

If your area is served underground, one or more underground facilities should be visible (see *Figure 1*). Please request a permanent underground service (*Chapter 2*).

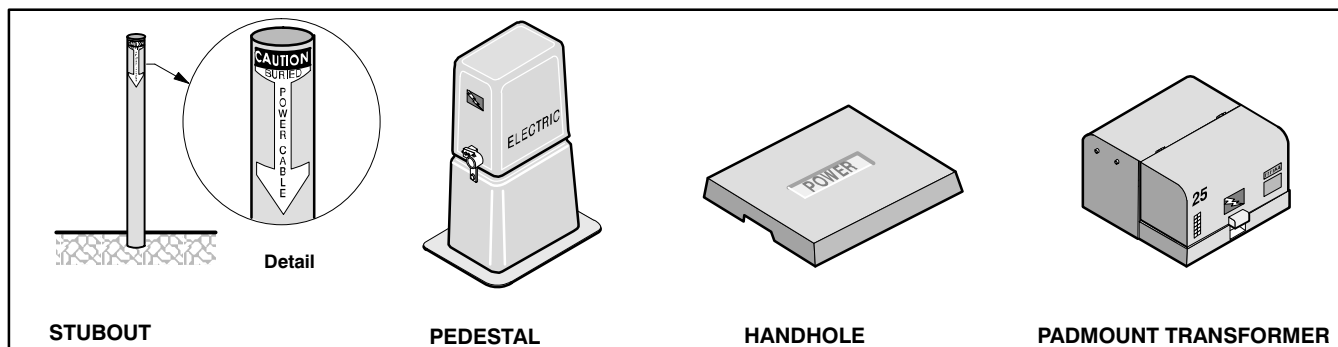

**Figure 1** Underground facilities

**Overhead service**

If the power system in your area is overhead, poles should be visible (see *Figure 2*). Please request a permanent overhead service (*Chapter 3*).

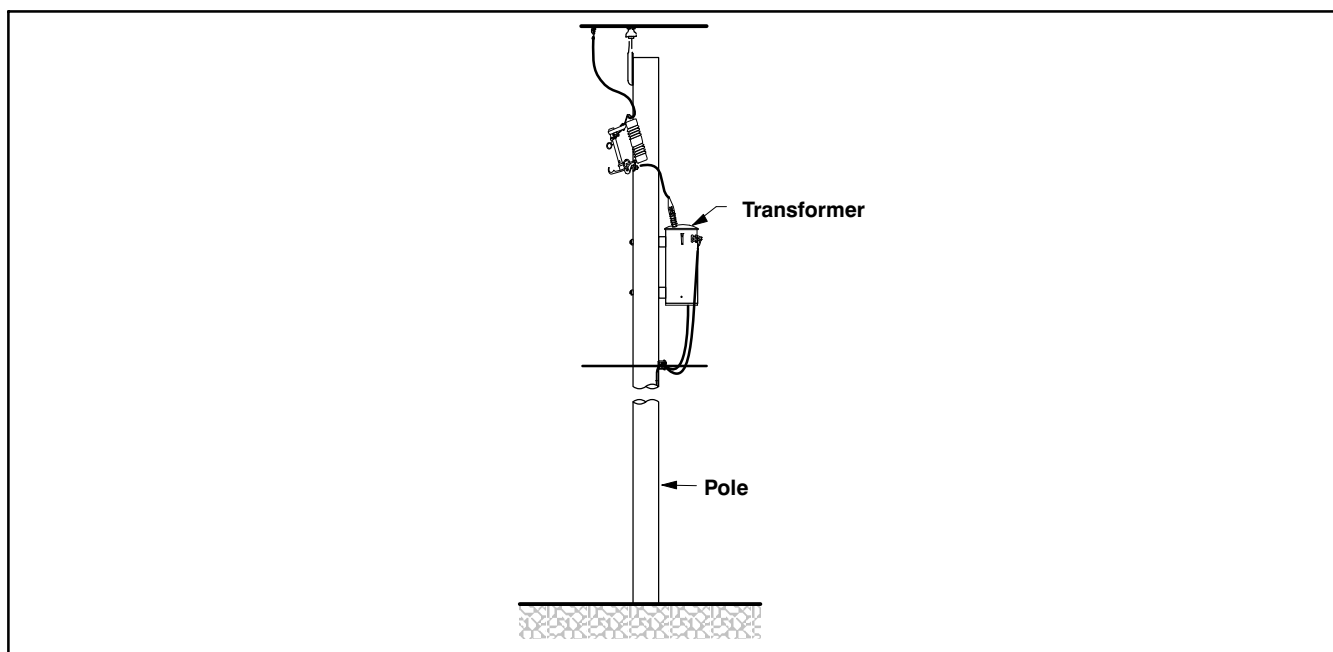

**Figure 2** Overhead facilities

**Which type of electrical system is available in your area?**

You can determine if PSE’s system is underground or overhead by checking for our facilities along your road. If the power system is underground, you’ll see facilities like those in *Figure 1*. If the power system is overhead, a series of poles similar to *Figure 2* will be visible.

Use *Table 1* to help you determine which type of electrical service can be provided. For help determining which type of system is in your area, call your *CCS Representative* at **1-888-321-7779**.

**Table 1** Types of electric services

If available electrical system is . . .	And if . . .	Then your service line will be . . .
Underground	<ul style="list-style-type: none"> <li>■ Your new meter location is less than 225 ft from our nearest underground transformer.</li> <li><b>NOTE:</b> If your new meter location is more than 225 ft from our nearest underground transformer, an additional transformer may be required.</li> </ul>	Underground
Overhead	<ul style="list-style-type: none"> <li>■ The new meter location is less than 200 ft from our nearest power pole.</li> <li>■ The service originates from the pole.</li> <li>■ The pole has a transformer on it (see <i>Figure 2</i>).</li> </ul>	Underground
Overhead	<ul style="list-style-type: none"> <li>■ The new meter location is less than 125 ft from our nearest power pole.</li> <li>■ The pole has a transformer on it (see <i>Figure 2</i>).</li> <li>■ Your service line does not cross anyone else's property.</li> </ul>	Overhead or Underground

*NOTE:* If your situation does not fit the criteria presented, please contact your *CCS Representative*.

---

### Other electric service information

If you need information on the installation of permanent or temporary multifamily and nonresidential services you will find it in the *PSE Electric Service Handbook for Commercial/Industrial and Multifamily Projects*.

All handbooks are available free of charge from PSE.

---

### How to contact Puget Sound Energy

Please direct any technical questions regarding the information in this booklet, to PSE's **Customer Construction Services Department** at **1-888-321-7779**.

You may also visit **PSE.com**, our web site for online applications, construction videos, energy efficiency programs, as well as other helpful information.

If you have any general billing questions regarding your account or questions about gas or electric service installation, please call **Customer Service** at **1-888-225-5773**.

---

### PSE's service providers

PSE contracts with two partner companies to provide construction and engineering services. Your *Project Manager* and the employees who install your service may work for these service providers on PSE's behalf.

## Overview:

### New Permanent and Temporary Electric Service Hookup to Existing PSE Power Facilities for Single-Family Residential Projects

This information applies only if PSE has existing power facilities in your area. If electric power is not readily available, please call:

#### **CUSTOMER CONSTRUCTION SERVICES**

**1-888-321-7779**

#### **Customer Responsibilities:**

- Determine if you need overhead or underground service.
- Call PSE to set up an account and submit an order.
- Obtain an electrical work permit.
- If temporary service, install temporary service facility and meter base.
- If permanent service, determine the service size amp rating you want (200, 320, or 400 A).
- Determine an approved permanent meter location.
- Call 811, at least two working days before you dig, or via the web (click ITIC at [callbeforeyoudig.org](http://callbeforeyoudig.org)).
- Prepare job site by providing a clear path/trench for your service line for proper vault entrance requirements per PSE standards.
- Obtain an approved electrical inspection.
- **After** the electrical inspection has been completed and approved, request PSE to install and energize your system.

#### **Puget Sound Energy's Responsibilities:**

- Connect temporary service.
- Determine if engineering is required.
- Install your overhead or underground permanent service line conductors.
- Install your meter and energize your system.

#### **Scheduling:**

- If engineering is not required, services are typically installed and energized 3 to 5 days after you have passed your inspection.

#### **Permanent and Temporary Service Charge:**

- Charges vary due to the type of service you request and the type of system we have in your area. Contact your *Customer Construction Services Representative* for current rate information.



## Chapter 1

# Steps to a Successful Permanent Electric Service Installation for Single-Family Residences

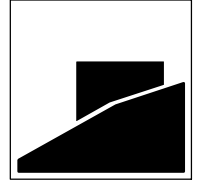

### Definitions

PSE defines a **single-family residence** as a structure that is:

- Located on a legal residential lot.
- **Approved** for occupancy as a permanent single-family residence by the local governing agency or agencies.
- A parcel where the lot line is extended to the public thoroughfare, even if the unit(s) shares a common wall(s) with other like living units, such as in zero-lot-line construction.

A **mobile or manufactured home** will be considered at single-family residence if it meets the above requirements, and:

- Is permanently located on a foundation.
- Has had the axles and wheels removed.
- Meets all other requirements for a mobile home permit as required by the local governing agency or agencies.

**NOTE:** A mobile or manufactured home located in a mobile home park does not qualify as a single-family residence.

### Service installation responsibilities

Installing new electrical service to your single-family residence is a joint project between you and PSE.

#### Puget Sound Energy

PSE is responsible for:

- Installing the service line conductors to a customer-installed and maintained **service mast** or underground meter service riser.
- Installing the meter in a customer-installed and maintained **meter base/socket**.
- Energizing your system.

#### Customer

You are responsible for:

- Determining if you need overhead or underground service.
- Setting up an account and submitting an Application for Service.
- Obtaining an electrical work permit.
- Determining the service size amp rating you want.
- Determining an approved meter location.
- Providing and maintaining a clear path/trench for your service line.

*Continued on next page*

- Calling for underground utility locates at least two working days before you dig, by calling 811, **1-800-424-5555**, or [callbeforeyoudig.org](http://callbeforeyoudig.org).
- Installing the meter base/socket on the outside wall in an *approved location*.
- Installing all the electrical wiring inside your residence.
- Obtaining a city or state inspection and approval of your installation.
- After your electrical inspection is complete, calling PSE to request that your service be installed and energized.
- Keeping your meter base/socket accessible to PSE.

---

## Starting the installation process

### Setting up an account or to order a new service

You may establish your billing account when you are ready to initiate your *temporary service* order, order your permanent service, or after the state electrical inspection is complete and your trench is ready (if applicable).

To establish an account with PSE, call CCS at **1-888-321-7779**. The *CCS Representative* will ask for your billing information and the address for new service. (New addresses are obtained from the U.S. Postal Service or the County Addressing Department.)

To order a new service, submit an *Electric Service Application Single-Family Residential 100E (Form 4414)* to your *CCS Representative*. All forms can be downloaded from **PSE.com**.

### Will your project need engineering?

A *CCS Representative* will ask you the following questions to help determine how your project is handled:

- What kind of residential building is this service for (home, barn, shop, etc.)?
- What is the building's square footage?
- What kind of electrical or gas appliances will you have (furnace, heat pump, air conditioning, water heater, etc.)?
- What size service panel will you be installing?
- When will you be ready for service?
- Do you need underground or overhead service?

**NOTE:** If a transformer or electrical service stubout is located on your property, your project probably will not require engineering. If no transformer or stubout is available, your project will require engineering, and our *CCS Representative* will ask you to complete and submit an *Electric Service Application Single-Family Residential 100E (Form 4414)*. All forms can be downloaded at **PSE.com**.

## Choosing the right service size

### Service voltages

PSE offers their customers the voltages shown in *Table 2*.

**Table 2** Standard voltages for residential customers

Service Type	Voltage
Single-phase	120/240 V, 3-wire *
Three-phase	120/208 V, 4-wire 277/480 V, 4-wire

\*Available for loads to a maximum *demand* of 100 kW. Larger loads may be served, if determined feasible by a PSE engineer. All motors must be rated 7-1/2 HP or less.

### Service sizes

PSE offers several service sizes for single-family residential structures and for outbuildings. The service size you need depends on both the size of your home and the power requirements of the equipment you will be installing in it. *Table 3* explains the sizes that are available.

**Table 3** Service sizes available from PSE

Voltage	Ampere Rating	Typical Use
120/240	200 A	Small and medium sized homes (most common size services)
	320 or 400 A	Large homes
	Over 400 A	Very large homes

### Sizes less than 200 A

You may install a service panel or meter base/socket that is sized less than 200 A, but the service line and meter that PSE installs will be sized as if you were installing a 200 A service.

If you are installing an underground service that is less than 200 A, your meter base/socket must meet the dimensional requirements for a 200 A underground meter base/socket, refer to *Chapter 5, Meter Installation*.

## Determining an approved meter location

**NOTE:** *Only* authorized and qualified PSE personnel shall install and remove meters.

### Customer-installed meter base/socket location

You are required to install your meter base/socket in a place that is accessible to PSE. All locations are subject to approval by a *PSE Representative*.

If you have questions regarding meter locations, call your *CCS Representative* at **1-888-321-7779**.

*Continued on next page*

Meter base/sockets, including CT *enclosures*, must be located:

- Outside.
- On the front 1/3 of your home closest to normal public access.
- In an area that is **not** subject to being fenced-in (patios, decks, porches, breezeways and backyards are bad locations).
- On a structure that is owned by you.

These approved locations allow us to:

- Read your meter in a cost-effective manner.
- Maintain your meter efficiently.
- Disconnect your service if there is a fire.

*NOTE:* Refer to *Installation Requirements for Underground Services (Form 3061)* for more information.

## Locating other underground utilities

### Locating existing underground utilities – *call before you dig!*

If you are trenching or excavating, underground locates are required by law. Call for underground utility locates **two full working days before you dig** by calling 811, **1-800-424-5555**, or [callbeforeyoudig.org](http://callbeforeyoudig.org) (refer to *RCW 19.122*).

The service will notify each member utility, or a locating service, who will locate the underground facilities in your area. **This service is free.** *Table 4* shows the color code for marking the location of each utility.

Once all utilities are located, hand dig within 24 inches of the locate marks to expose all utilities to be crossed.

**Table 4** Color codes for locating utilities

Color	Utility
White	Proposed excavation
Pink	Temporary survey markings
Red	Electric power lines, cables, conduit, and lighting cables
Yellow	Gas, oil, steam, petroleum, or gaseous materials
Orange	Communication, alarm or signal lines, cables, or conduit
Blue	Potable water
Purple	Reclaimed water, irrigation, and slurry lines
Green	Sewers and drain lines

*NOTE:* Use white paint to mark the area where you want utility locations.

## Coordinating utility trenching and construction

New construction typically involves the installation of telephone cables, cable television cables, and natural gas lines; as well as electric power cables.

**It is the responsibility of you and your builder** to notify each utility about your intended electric service installation as well as all other utilities providing service to your new structure.

## Transformer locations

PSE will install padmount transformers using the *clearances* listed in *Table 5* and shown in *Figures 3* through *6*.

Clearances between padmount transformers and structures must be measured from the metal portion of the transformer closest to the building or structure (including any overhangs).

**Table 5** Clearances for padmount transformers

Feature	Clearance distance
Combustible walls or roof (including stucco).	10 feet (3 ft from a combustible wall if using a reduced flammability transformer). See <i>Figure 4</i> .
Noncombustible walls (including brick, concrete, steel, and stone), provided the side of the transformer facing the wall does not have doors. Materials that pass UBC Standard 2-1 or ASTM E136-79 are considered to be noncombustible.	3 feet. See <i>Figure 4</i> .
Fire sprinkler valves, standpipes, and fire hydrants.	6 feet. See <i>Figure 3</i> .
Doors, windows, vents, fire escapes, and other building openings.	10 feet. See <i>Figure 3</i> .
The water's edge of a swimming pool or any body of water.	15 feet. See <i>Figure 3</i> .
Individual domestic and irrigation wells.	100 feet. See <i>Figure 3</i> .
Facilities used to dispense or store LP or hazardous liquids or fuels.	20 feet. See <i>Figure 5</i> . 10 feet. See <i>Figure 5</i> .
Gas service meter relief vents.	3 feet. See <i>Figure 3</i> .

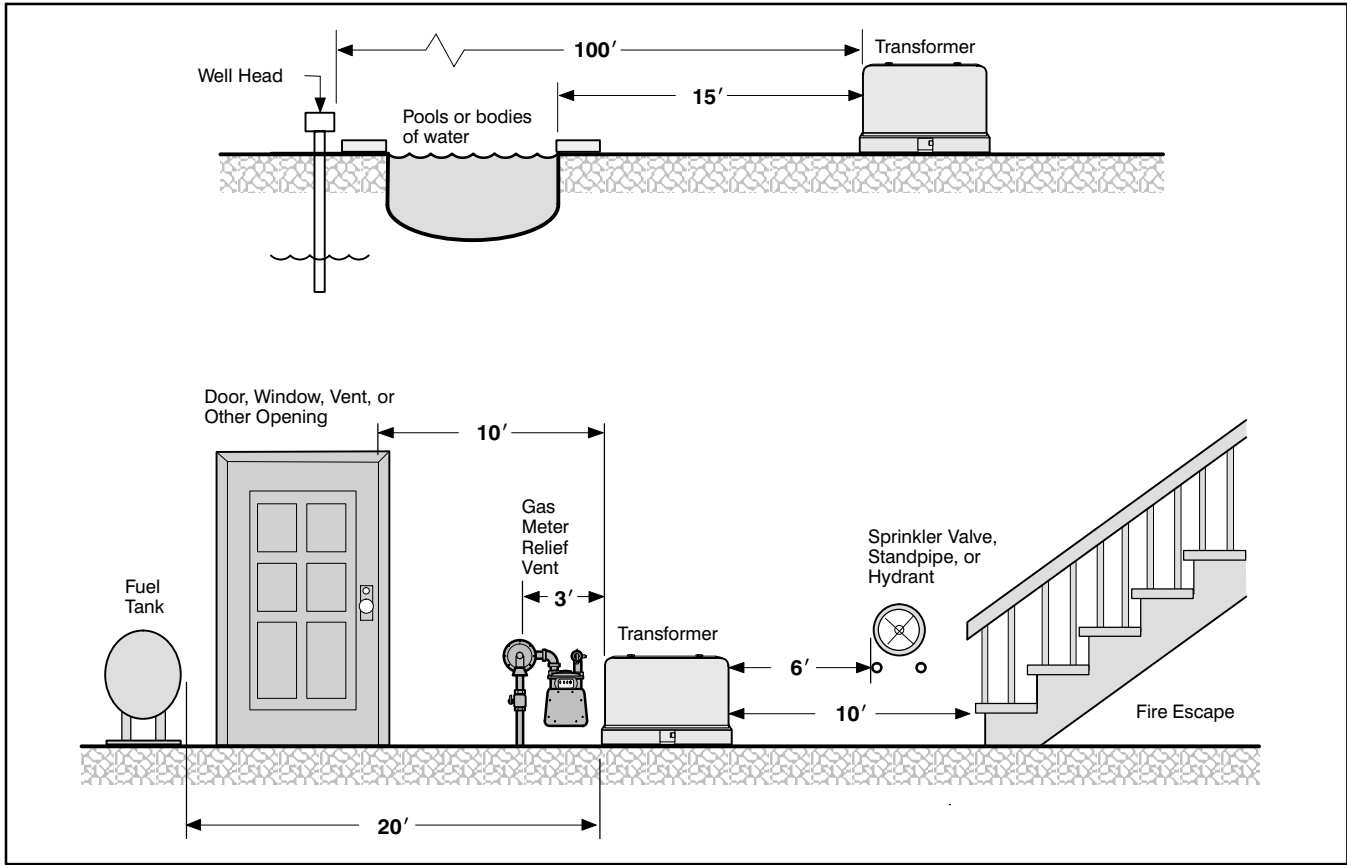

Figure 3 Clearances for transformers

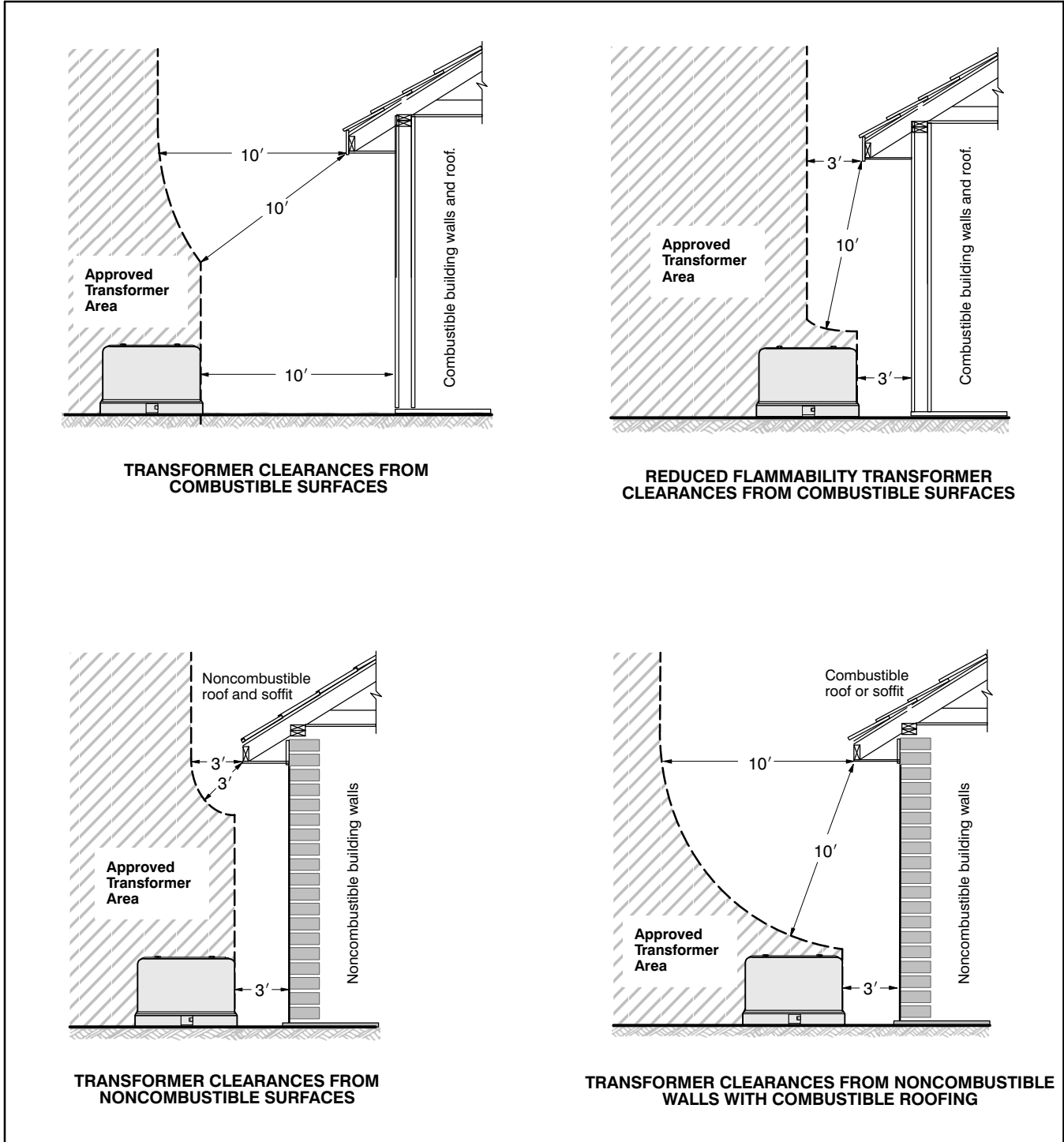
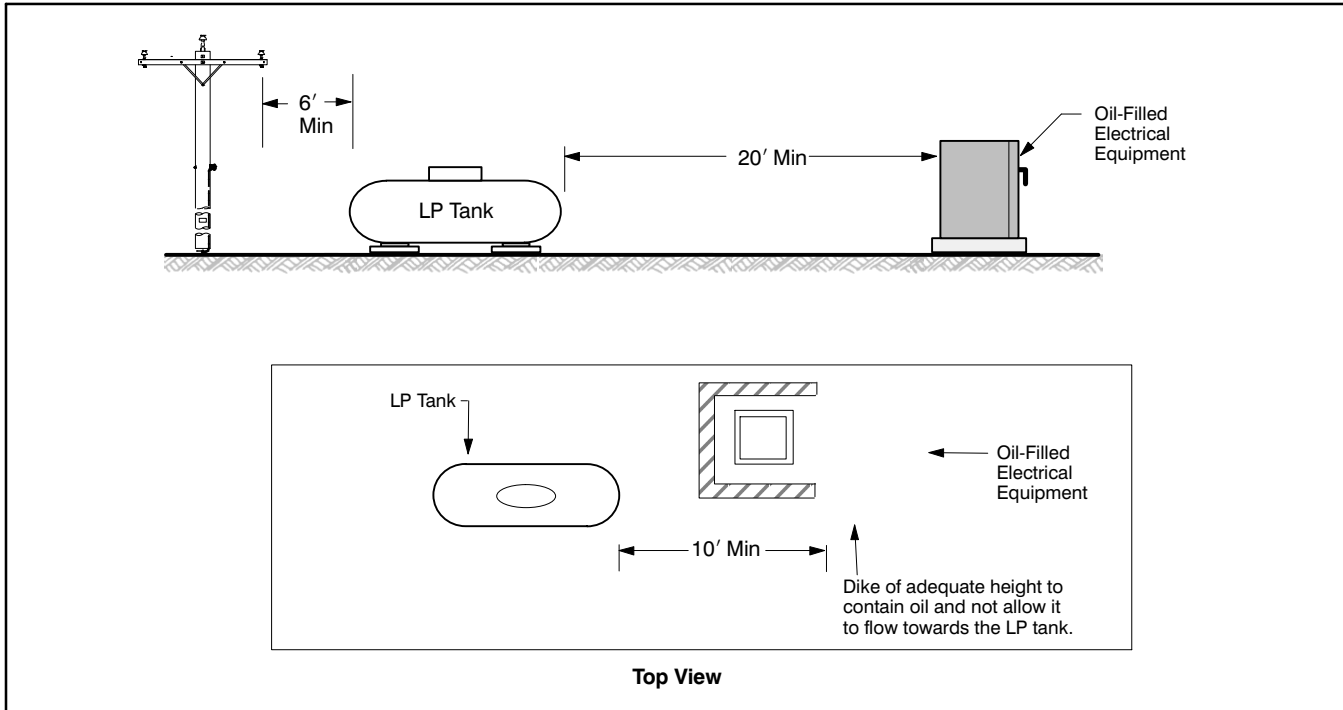

Figure 4 Clearances for transformers from structures

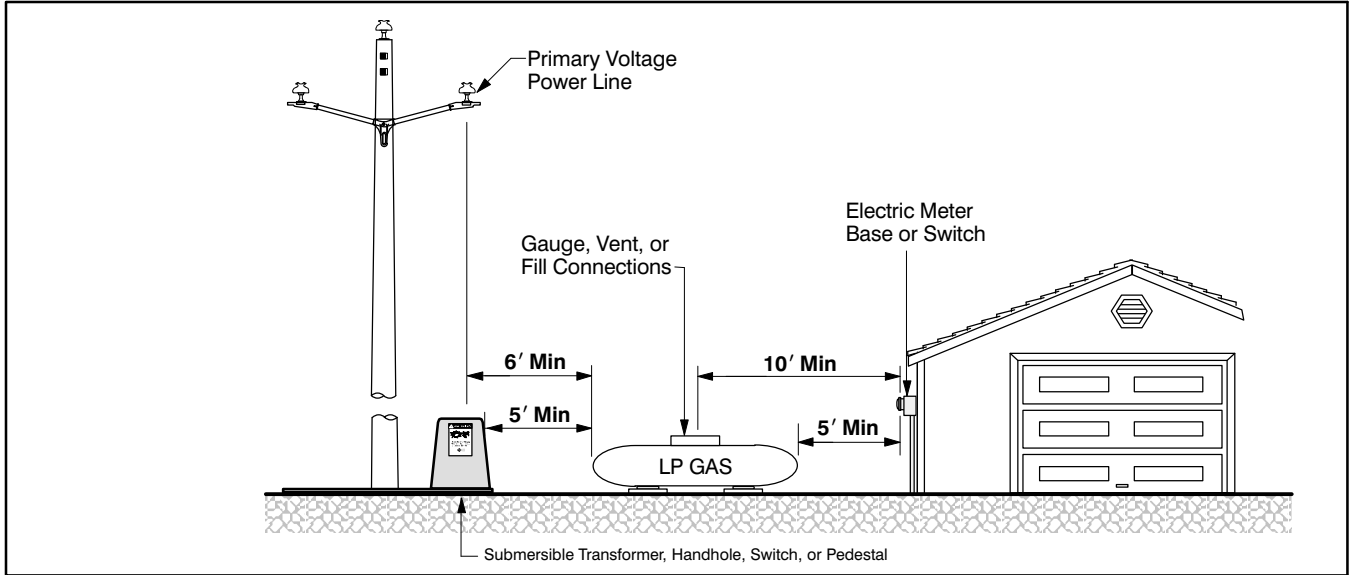

**Figure 5** Minimum clearances from oil-filled equipment to LP, hazardous liquid, or fuel tanks

### Liquefied propane tanks: clearances from ignition source

If there are liquefied propane (LP), hazardous liquid, or fuel tanks on your property, the following minimum clearances apply from PSE's padmounted transformer or the ignition source (see *Figures 5 and 6*).

- All LP tanks must be at least 6 feet from a vertical plane extending down from an overhead primary voltage line.
- Consumer storage LP tanks must be at least 5 feet from any source of ignition, such as electric meter bases, submersible transformers, secondary handholes or pedestals, or padmount switches.
- The fill connection, gauge connection, or vent on the LP tank must be at least 10 feet from any source of ignition.



**Figure 6** Minimum clearances from LP storage tanks to sources of ignition

## Outbuildings

An outbuilding is a stand-alone structure which is located on residential property and is **not a living space**. Typical outbuildings are barns, pump houses, garages, shops, and storage sheds.

### Service line installation responsibilities for outbuildings

An underground service line to an outbuilding is installed by the customer or PSE, depending upon the intended use of the outbuilding (see *Table 6*).

If you want PSE to install a separate service to your outbuilding, refer to the *Service Installation Responsibilities* section at the beginning of this chapter.

**Table 6** Service line installation responsibilities

If the primary use of Outbuilding is for . . .	Service line will be installed and maintained by . . .
Commercial purposes or a pump house for a multifamily/community well serving more than 2 households.	Customer
General residential (garages, shops, small barns and well pump houses serving up to 2 households).	Puget Sound Energy

**NOTE:** Installation costs and billing rates are different for the each type of primary use of outbuildings. Contact your *CCS Representative* at **1-888-321-7779** for more information.

## Cost for service

Charges vary depending on the location of existing electrical facilities, the type of service you are requesting, and the distance to run service from our facilities to your home. Contact CCS at **1-888-321-7779** to determine the cost for service.



## Chapter 2

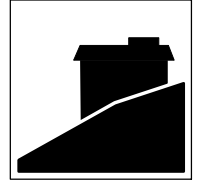

## Permanent Underground Service

### Steps to a successful underground service installation

The following list details the key steps in the installation of your underground service resulting in PSE's installation of your underground service line and meter (see *Figure 7*).

- Find out where your service line will originate by contacting Customer Construction Services (CCS) at **1-888-321-7779**.
- Obtain an electrical work permit.
- Determine an acceptable location for your meter base/socket.
- Call for underground utility locates at least two working days before you dig, by calling 811, **1-800-424-5555**, or [callbeforeyoudig.org](http://callbeforeyoudig.org).
- Dig a trench from your meter location to the location where your service line will originate (transformer, handhole, pole, or stubout).
- Provide 4-foot-square work pits at poles, stubouts, handholes, and meter service entrance.
- Provide conduit for electrical service lines that are less than 100 feet and a pull rope if over 60 feet.
- Install your meter base/socket *service entrance equipment*.
- Obtain a city or state electrical inspection and approval of your installation.
- Call CCS at **1-888-321-7779** to have your service installed and energized.

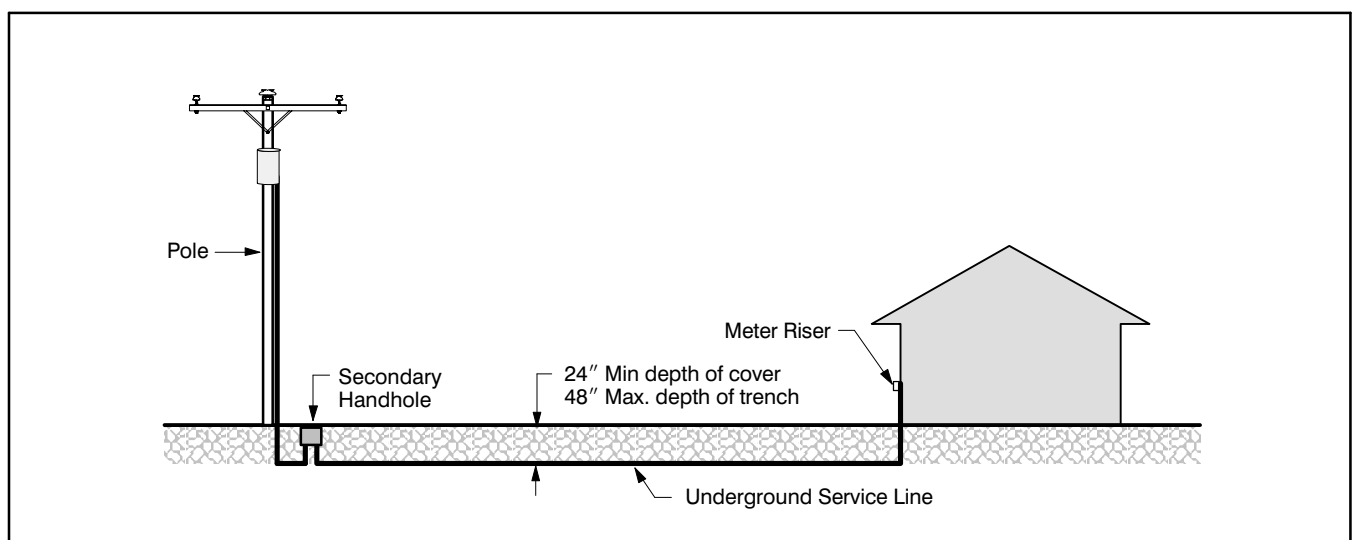

**Figure 7** Typical underground service from overhead power facilities

## Selecting a meter base/socket location

When choosing your meter base/socket location, be sure to consider the types of terrain where your service line will be buried. Since PSE is responsible for repairing your service line if it fails, the path you select is subject to being dug up. Therefore, we recommend that the service line route be accessible for repairs and excavation.

*NOTE:* Refer to *Chapter 1, Determining an approved meter location* section, *Customer-installed meter base/socket location* subsection.

## Multiple metered services

If a residential class customer installs a bus gutter or meter-pack enclosure to set **two meters** (one meter for the house, the other for the shop, barn, garage, etc.) **on a single piece of property being billed to the same individual**, PSE will run a single service line at the customer's request. However, the single line must accommodate the kW load and limit the voltage drop and voltage flicker to within PSE's standards.

*NOTE:* PSE will **not** run a single service line to a bus gutter or meter-pack that serves multiple residential class customers residing on differing properties with separate legal ownership.

---

## Service line trenches

This section refers to the illustrations found in *Installation Requirements for Underground Services (Form 3061)*, located in the back pocket of this handbook.

## Trench and backfill requirements

PSE will allow customer-owned facilities within the service line trench, if the following minimum horizontal clearances from PSE facilities are maintained:

- 18 inches minimum for customer-owned tight-line sewer (not tile), storm drain lines, roof drain lines, natural gas line, propane gas line, fuel oil line, and water mains up to 6 inches.
- 12 inches minimum for water services, irrigation pipes, lighting, security and electric supply circuits, closed-system roof drains/storm drains (not French drains), and culverts.

*NOTE:* *Installation Requirements for Underground Services (Form 3061)* illustrates the service trench requirements in detail.

## Customer-installed service line conduit

If your service line will be crossing under any permanent structure (driveways, sidewalks, decks, patios, rockeries, retaining walls, or through your backyard), you are required to provide and install conduit under those obstructions.

You are required to provide an electrical service line conduit for services 100 feet long or less. However, PSE recommends the use of conduit for all services.

### Customer-installed service line conduit installation requirements

- The service line conduit shall be gray, electrical grade schedule 40 PVC conduit with a minimum 2-1/2 inches in diameter for runs of less than 100 feet, and 3 inches for runs greater than 100 feet.
- **White water pipe or green sewer pipe is not acceptable.**
- The service line conduit shall contain no more than a total of 180 degrees of bends of which no individual bend is less than a 24-inch radius.
- Install a 3/8-inch pull rope in the conduit (if conduit runs are 60 feet or more).
- Stop the conduit 4 feet from the pole in the work pit with the pole butt exposed.
- **Do not** provide a conduit elbow at the base of PSE's pole, and **do not install conduit on a PSE pole.**
- When installing conduit at a transformer, stop 2 feet from the entrance at the bottom of the transformer mini pad (see *Chapter 4, Figure 20*).

*NOTE:* Details of a service line trench with customer-installed conduit is shown in *Installation Requirements for Underground Services (Form 3061)*, found in the back pocket of this handbook.

---

### Service entrance equipment

Determine the meter base/socket location, the service line route, and the size of the service you want (for example, 200 A), before you begin installing your service entrance equipment.

#### Installation requirements

- Service entrance equipment can be installed either flush-mounted or surface-mounted (see *Figure 8*).
- Install the meter base/socket so that the center of the meter will be between 4 and 6 feet above finished grade with a 5-foot height being preferred.
- The service entrance conduit has a maximum of one 45-degree or 90-degree bend with a minimum 24-inch radius.
- You may not use “LB” joints, conduits, or devices that allow access to the service conductor in the riser ahead of the meter.
- A CT enclosure, if required, must be mounted on the outside of the structure it serves.

*NOTE:* Service entrance equipment for a 401–800 A installation is shown in *Figure 9*.

#### Service entrance conduit size

*Installation Requirements for Underground Services (Form 3061)* illustrates the service entrance conduit size requirements in detail.

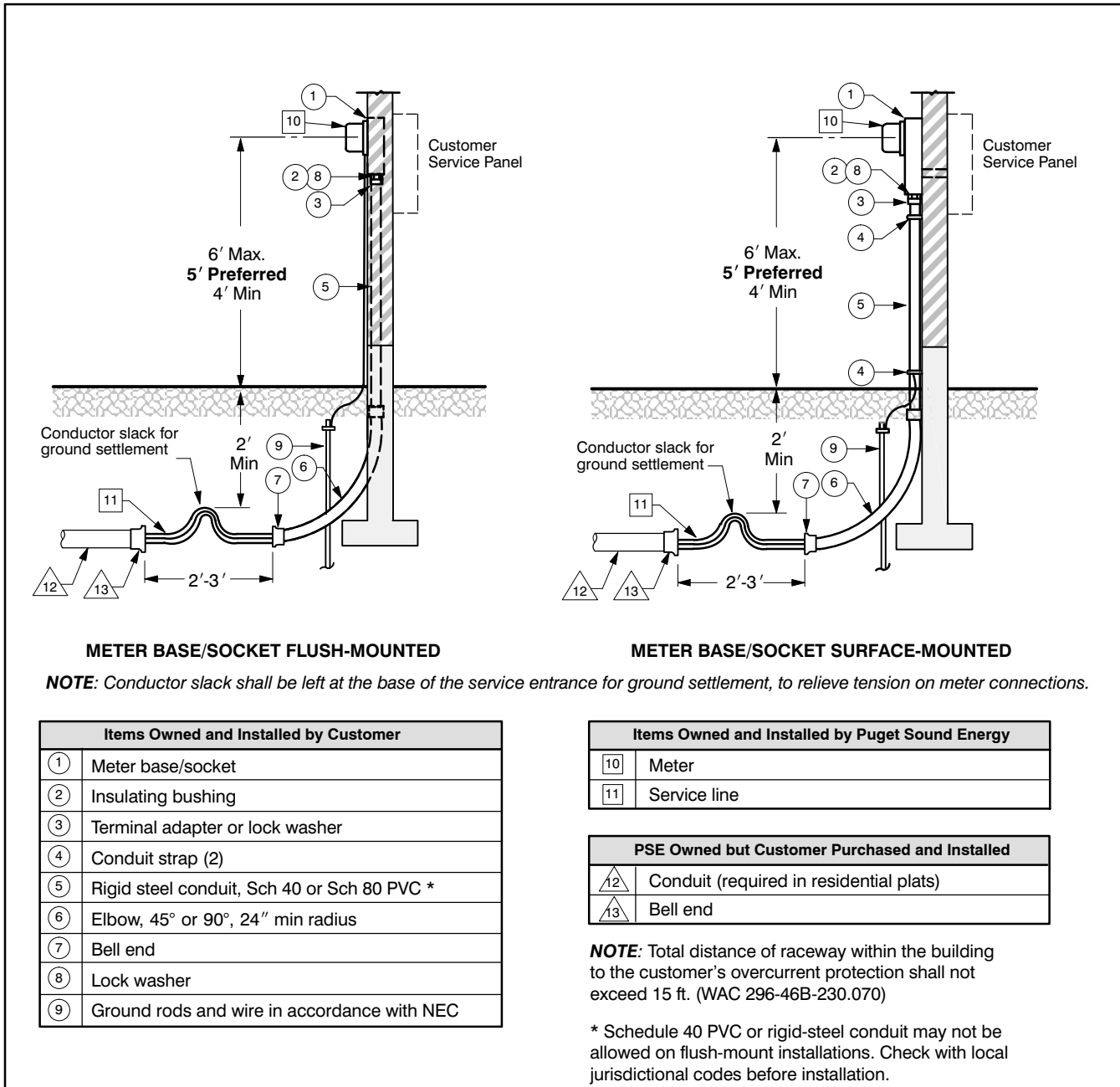

**Figure 8** Two types of meter bases/sockets for permanent underground service

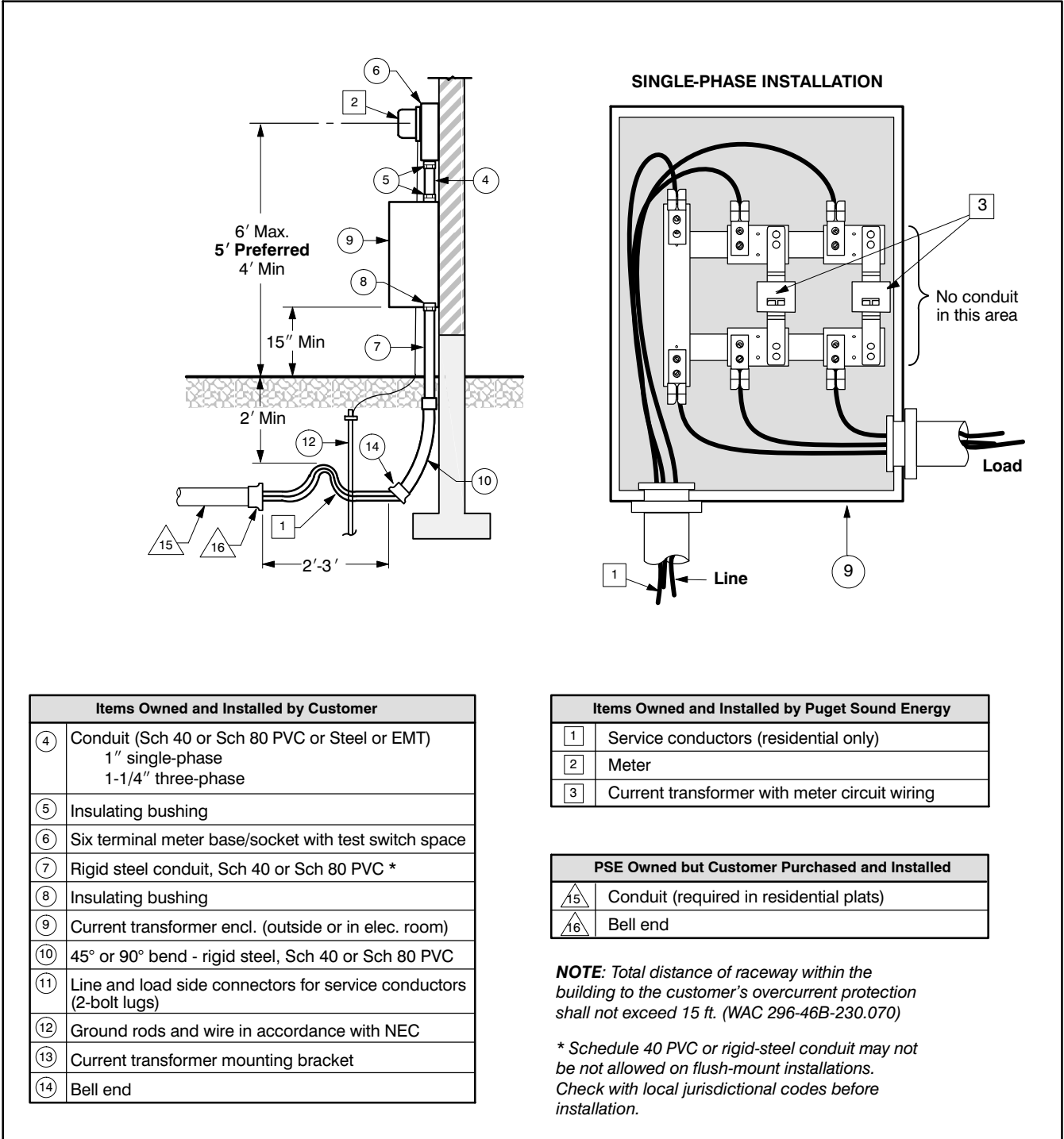

Figure 9 401-800 A service entrance equipment

## Permanent underground service for manufactured homes, 0–200 A

### Service equipment installation

If you are installing an underground service to your manufactured home, your service equipment can be installed one of two ways:

1. On a customer-owned pedestal or meter post (see *Figure 10*).
2. On the manufactured home, if both of the following conditions are met:
  - The manufacturer installed the service equipment at the time your home was built.
  - The service equipment meets the meter base/socket requirements listed below.

### Meter base/socket requirements

Meter base/sockets installed on manufactured homes must:

- Be located on an outside wall of your home.
- Be located on the front one-third of your home closest to normal public access. Refer to *Meter Locations and Clearances* on Page 1 of *Installation Requirements for Underground Services (Form 3061)* for more information.
- Be between 4 and 6 feet above finished grade.
- Meet PSE's service entrance conduit size requirements.
- Not be in a walkway or breezeway.
- Not be in an area that is subject to being fenced.

**NOTE:** Meter bases/sockets not installed on the manufactured home must meet the requirements of NEC 550.32(B).

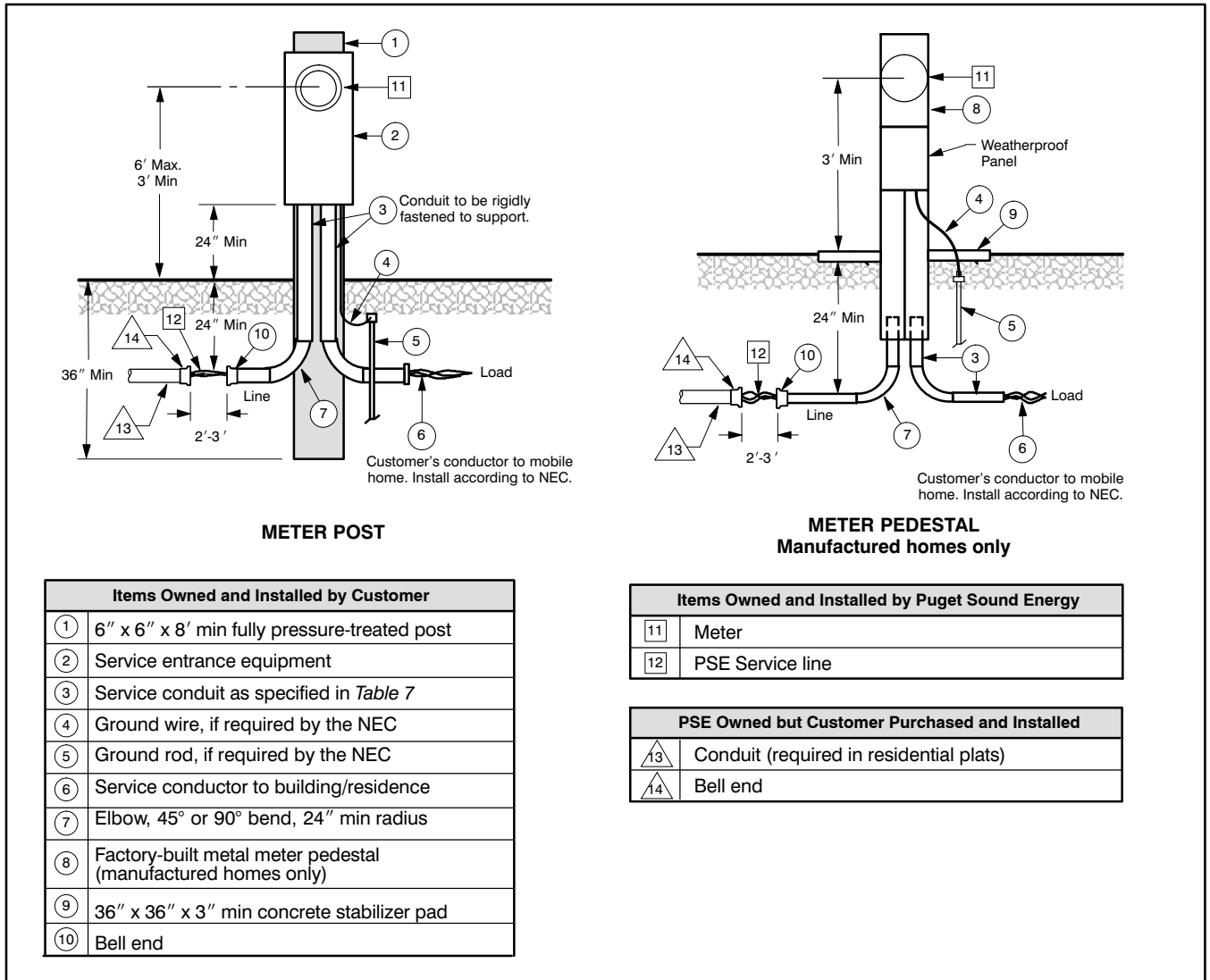

Figure 10 Permanent underground service for manufactured homes, 0–200 A

## Remote metering (meter loop) for underground residential services

### What is remote metering?

Normally, a meter base/socket and associated devices (current transformers, etc.) are attached to a permanent fixed structure that contains the load being served (such as a house). If the *metering equipment* is not attached to the permanent structure, it is called “remote metering.” In this case, the conductors that run from the meter to your house are installed, owned, and maintained by you.

### Requirements for single-family residential remote metering

Remote metering shall be mounted on a structure or meter post. It is your responsibility to purchase, install, and maintain this equipment. The required metering cabinet and supporting structure are shown in *Figure 11*.

**400 A and larger panels**

Meter installations that require current transformers may be installed on meter posts.

**Meter post and pedestal locations**

Remote metering must be:

- Accessible for reading and maintenance during normal business hours.
- Not be in a walkway or breezeway.
- Not be in an area that is subject to being fenced or enclosed.
- Safe parking must be located within 50 feet of the meter.

**NOTE:** When installed close to PSE’s transformer, all metering equipment must be a minimum of 3 feet from the transformer and not installed in front of the transformer.

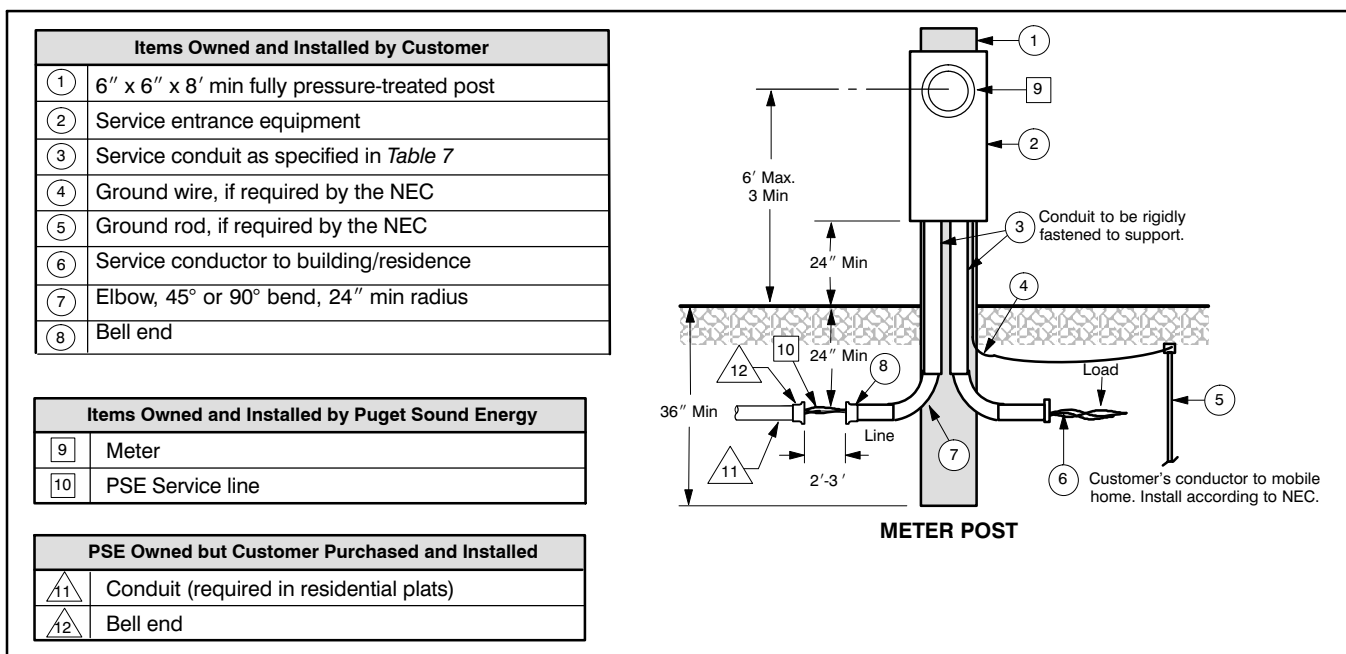

**Figure 11** Remote metering for underground residential services

## Chapter 3

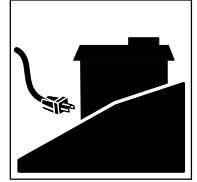

# Permanent Overhead Service

## Steps to a successful overhead service installation

The following checklist will assist you in preparing for the installation of an overhead service (see *Figure 12*). After you have completed these items, PSE can install the overhead service line and meter.

- Check for any local ordinances/covenants that prevent you from obtaining an overhead service.
- Obtain an electrical work permit.
- Complete *Electric Service Application Single-Family Residential 100E (Form 4414)*. All forms can be downloaded at **PSE.com**.
- Supply site drawings and load information to your PSE *Customer Construction Services (CCS) Representative*.
- Call CCS to find out where your service line will originate.
- Determine an acceptable location for your meter base/socket.
- Provide a path clear of obstructions between PSE's service pole and your *service mast*.
- Provide the location of any domestic or community water well on your property.
- Install the required *service entrance equipment*.
- Install the *service entrance conductors* (leave a minimum of 18 inches exposed at the weatherhead).
- Verify that the service mast height requirements have been met (see *Figure 13*).
- Provide payment for any preconstruction costs determined by CCS.
- Have the city or state inspect and approve your installation.
- Call CCS at **1-888-321-7779** to have your service installed and energized.

## Selecting a meter base/socket location

After CCS determines which pole the service line will come from, you can determine the location of your meter base/socket.

Your meter base/socket should be located outside and on the front one-third of your structure closest to normal public access. Refer to *Installation Requirements for Underground Services (Form 3061)*.

Consider the type of terrain the line will cross, when choosing a meter base/socket location. PSE strongly suggests avoiding service line routes that cross a driveway. Service lines that cross driveways can be hit by vehicles, which can cause damage to the service equipment and even to your home.

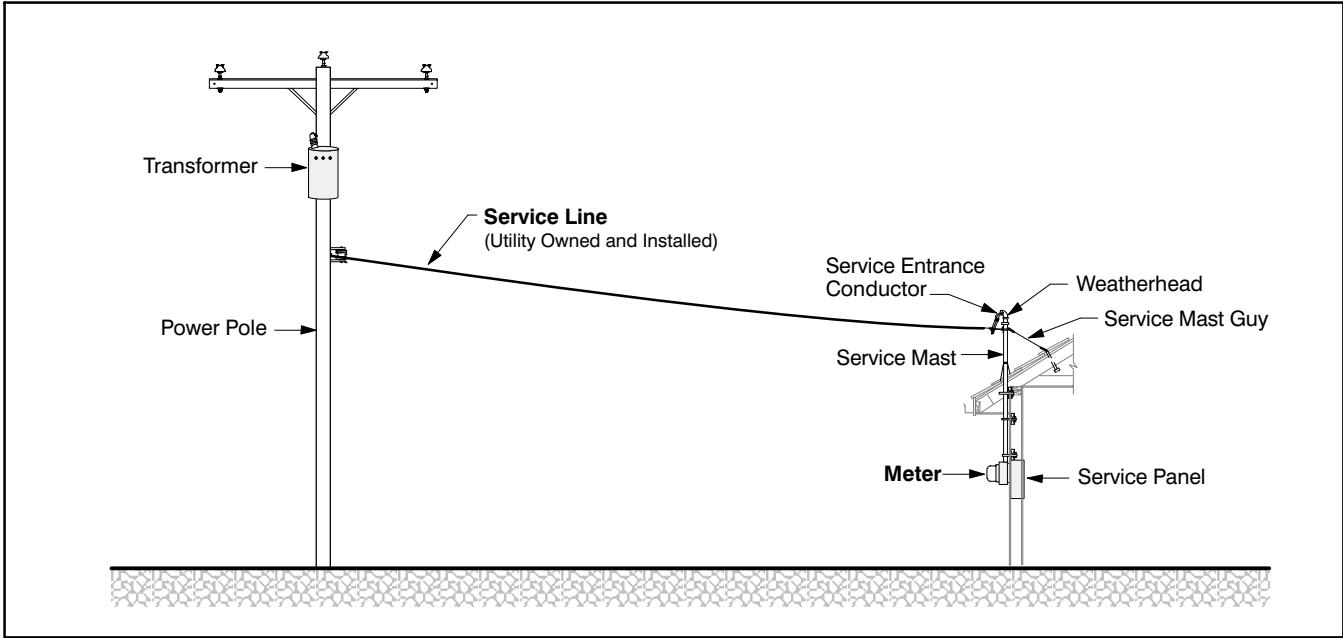

Figure 12 Typical overhead service installation

## Clearance requirements

### Service line ground clearance

The National Electric Safety Code (*NESC*) establishes minimum clearance requirements to maintain safe height requirements for electrical conductors over various terrain (see *Figure 13*).

The NESC requires the lowest point of a service conductor to be at least 12 feet above the ground. The bottom of the *drip loop* must be a minimum of 10 feet above the ground.

If the service line will pass through any trees, **you are required** to prune those trees to provide a clear path for the service line. **You are also responsible** for regular tree pruning, and if necessary, tree removal to keep the path clear.

It is **not** your responsibility to string the conductor, but you are required to provide a **point of attachment** at your service mast that will allow PSE to install the conductor and maintain the required clearances.

If you need further details, please contact the state or local electrical inspector for your area.

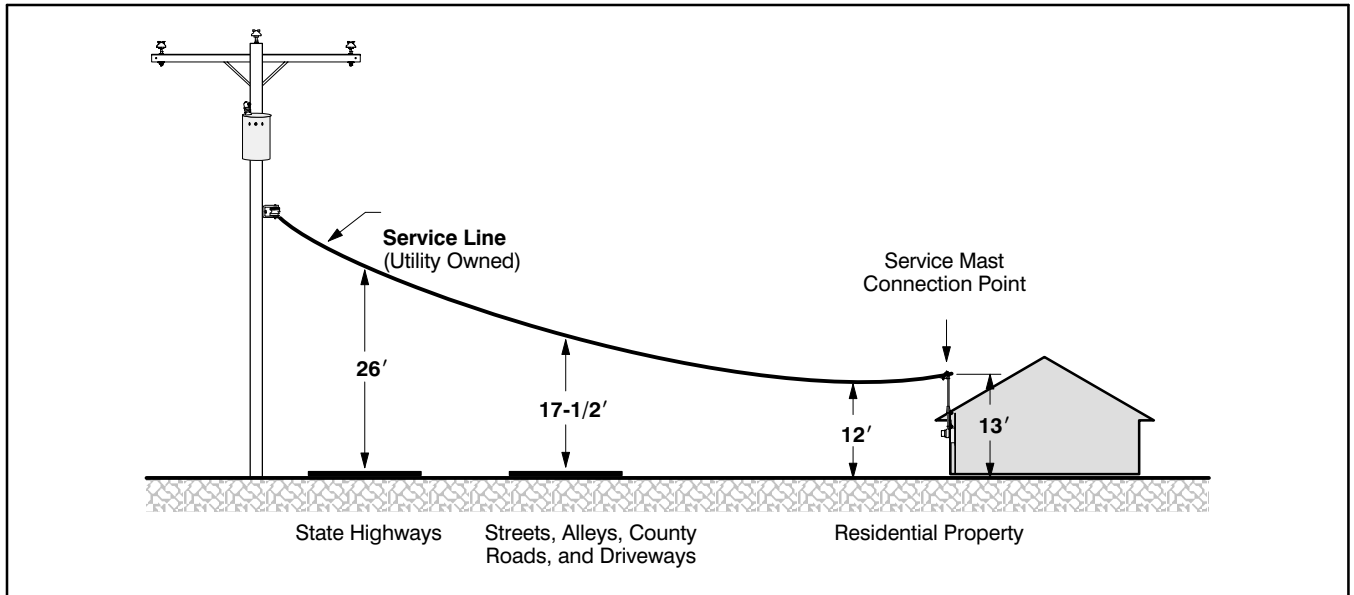

**Figure 13** Minimum overhead service line vertical clearances from ground level

**Minimum clearances from structures, building openings, and gas meters**

- A minimum clearance of 3 feet is required between electric service lines and windows, doors, porches, fire escapes, or similar openings.
- A minimum horizontal clearance of 3 feet is required between electric service equipment and natural gas meter pressure relief vent (see *Figure 14*).
- Service lines passing over the roof of another structure (but not attached to that structure) must maintain the minimum clearances (see *Figure 14*).
- Service lines passing over a deck must maintain a minimum clearance of 11 feet (see *Figure 14*).

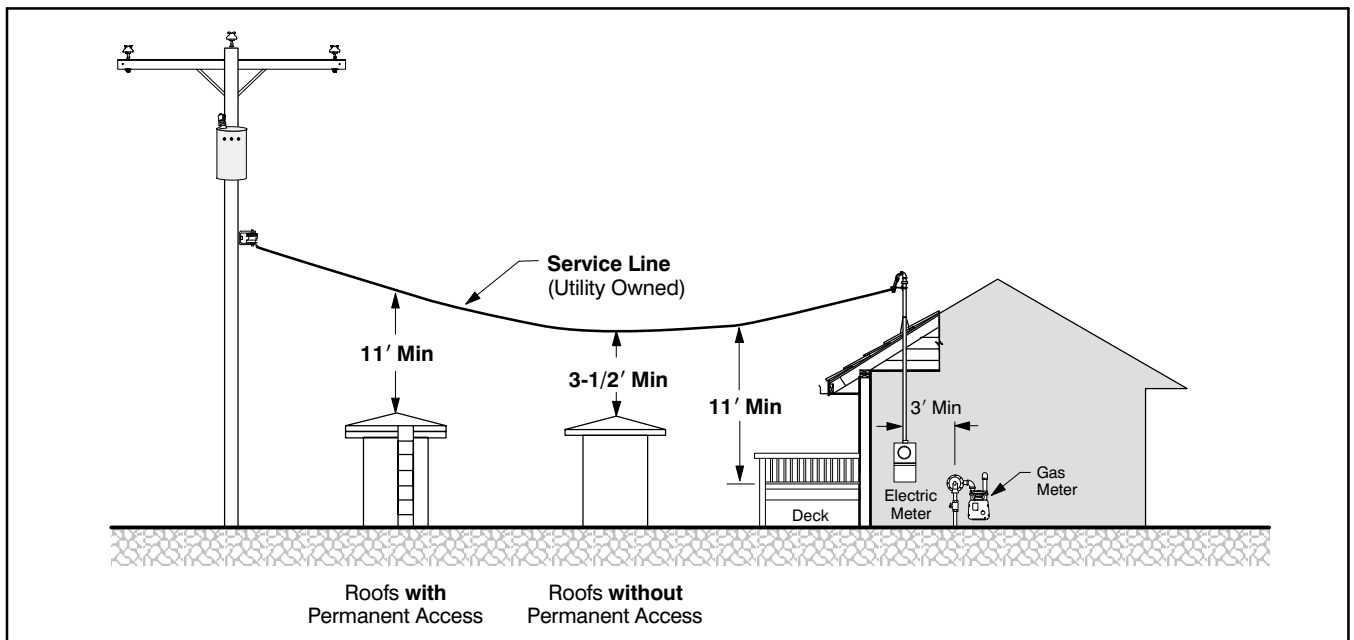
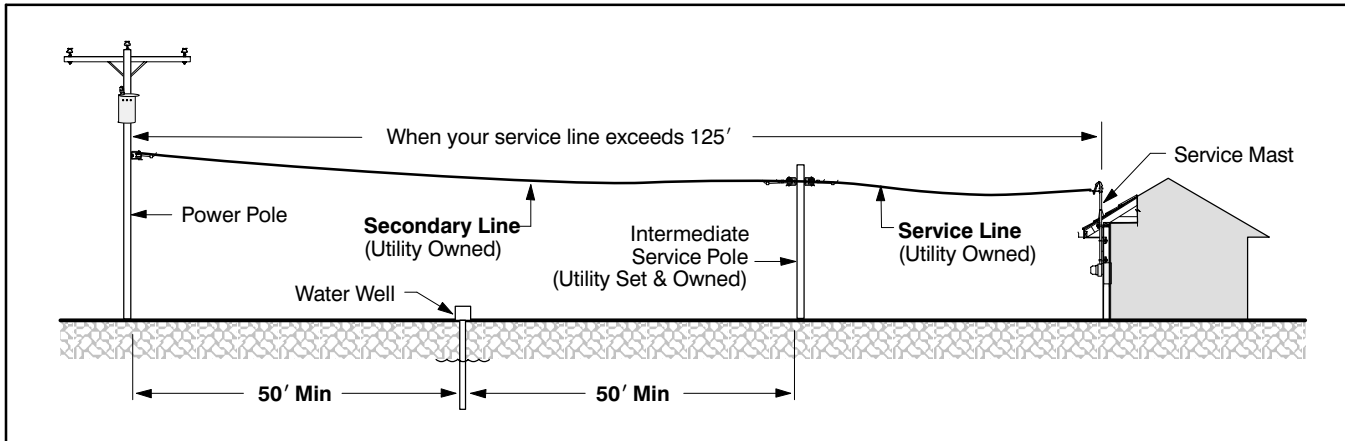

**Figure 14** Minimum clearances over other structures

### Intermediate service pole

When the length of an overhead service line exceeds 125 feet or the clearances shown in *Figure 14* cannot be achieved, an intermediate service pole may be required to maintain safe ground clearance (see *Figure 15*) for the wire and to relieve excessive tension at the *service mast*

This intermediate service pole is set and owned by PSE and the cost is in addition to the service line costs. Please contact CCS for installations that may require an intermediate service pole.



**Figure 15** Intermediate service pole location

### Service mast

A service mast is a rigid steel conduit that runs vertically from the top of your meter base/socket up through your roof. It contains your service entrance conductors and typically supports one end of your service line. Service masts are necessary when installing an overhead service and are installed by you or your electrical contractor.

### Service mast requirements

The service requirements for the installation of the service mast are located in the National Electric Code (NEC). Some of the more common methods are included in this section (see *Figures 16* and *17*).

### Height requirements

The service bracket (the point of connection with PSE's service wire at the top of your service mast) must be at least 13 feet above final grade or terrain so that the minimum clearances over your property can be maintained. Additional height may be required depending on the location and type of structure or terrain which your service line passes over.

The NEC also requires that your service mast maintain minimum clearances above your roof (see *Figure 16*). The clearance required depends on the slope of your roof, and whether or not your service line is attached to the structure.

For other options and details refer to the NEC. Your *CCS Representative* can assist you with determining the proper mast height.

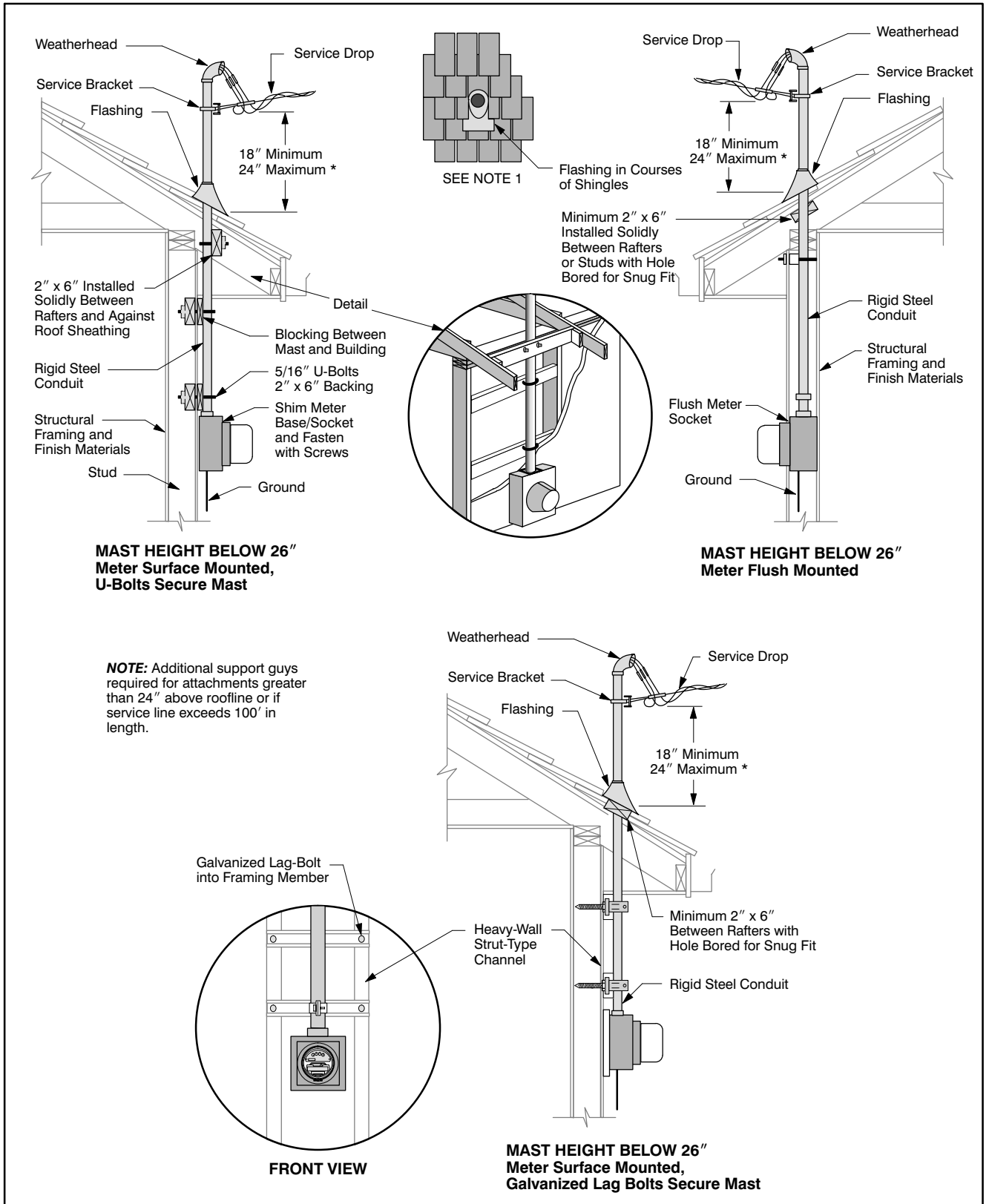

Figure 16 Unguyed service masts

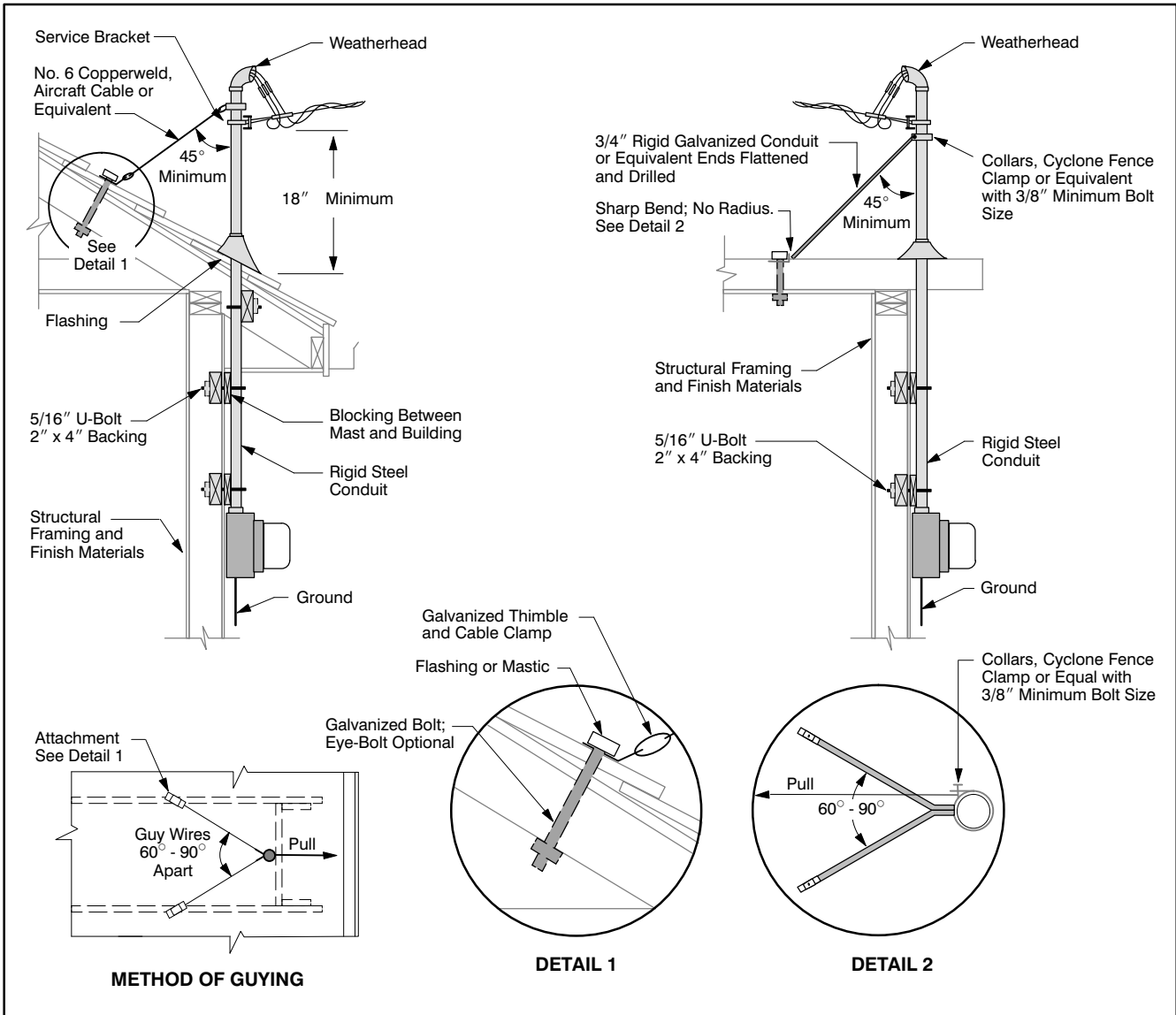

Figure 17 Guyed service masts

### Additional mast supports (guy or brace)

Additional mast supports, typically a *guy* or a brace, are required for any service line if:

- The service line is over 100 feet long; or,
- The point of attachment is more than 24 inches above your roof (see *Figure 17*).

Guys and braces are installed to prevent the weight of the service line from pulling your service mast away from your home or damaging your roof.

Further information regarding guying and bracing service masts is available in the NEC.

### Screw-in service knobs

For new or altered overhead service lines, you must provide a substantial *point of attachment* that meets NEC requirements. Older type screw-in service knobs attached to the home's wall are often inadequate to support modern triplexed service lines. PSE may prohibit use of service knobs if deemed inadequate.

---

## Service entrance equipment installation requirements

After you have determined the meter base/socket location, the service route, the height of your service mast, and the size of your service (200 A, 400 A, etc.); you are ready to begin installing your service entrance equipment.

Once you have installed your meter base/socket and mast you are ready to provide and install your *service entrance conductor*. The service entrance conductor is the wire that is connected to the top lugs in your meter base/socket and runs up through the service mast.

The service entrance conductors must be sized according to the NEC and to the rating of your meter base/socket. When installing the wire, leave at least 18 inches of it exposed at the end of the weatherhead to allow PSE to connect your service line to it. When you install your meter base/socket, make sure the center of the meter will be between 4 and 6 feet (5 feet preferred) above finished ground level.

If you have any questions regarding the installation of your service equipment, we suggest that you refer to the NEC, call the inspecting agency for your area, or contact an electrical contractor.

---

## Manufactured homes

If you are installing an overhead service to a manufactured home, our service equipment can be installed one of two ways:

1. On a customer-owned *meter pole*, or
2. On the manufactured home, if both of these conditions are met:
  - a. The manufacturer installed the service equipment at the time the home was built, and
  - b. The service equipment meets the meter base/socket requirements listed below.

### Meter base/socket installation requirements for manufactured homes

Meter base/sockets installed on manufactured homes must be:

- Located on an outside wall of your home and accessible for reading and testing.
- Located on the front one-third of your home closest to normal public access.
- Between 4 and 6 feet above finished grade.

*NOTE:* Do **not** locate the meter base/socket in an area that is subject to being fenced.

---

### Customer-owned meter pole

#### Meter pole requirements

If a meter pole is required for the project, it is your responsibility to purchase and install it. The meter pole must meet the following requirements:

- Be sound, round, reasonably straight, and made of wood.
- Fully pressure treated.
- Class 6 or better with a minimum diameter of 5-1/2 inches at the top.
- 30 feet long minimum (25 feet with prior approval).
- Butt gain cut 12 feet from the bottom of the pole (2-inch by 1/2-inch cut into the face of the pole), or a manufacturer's tag attached at 12 feet from the bottom of the pole.

#### Installation requirements

The installation requirements for a meter pole are:

- Must be buried a minimum of 10% of the pole's length plus 2 feet. If soil conditions are poor, crushed rock should be used as a substitute for backfill to stabilize the pole.
- Must be guyed if the service line crosses a public road or if the distance between the meter pole and PSE's pole is greater than 70 feet. A push brace or pole key brace may be used if guy space is not available.

A meter pole installation is shown in *Figure 18*.

If you have any questions, contact your *CCS Representative* for further assistance.

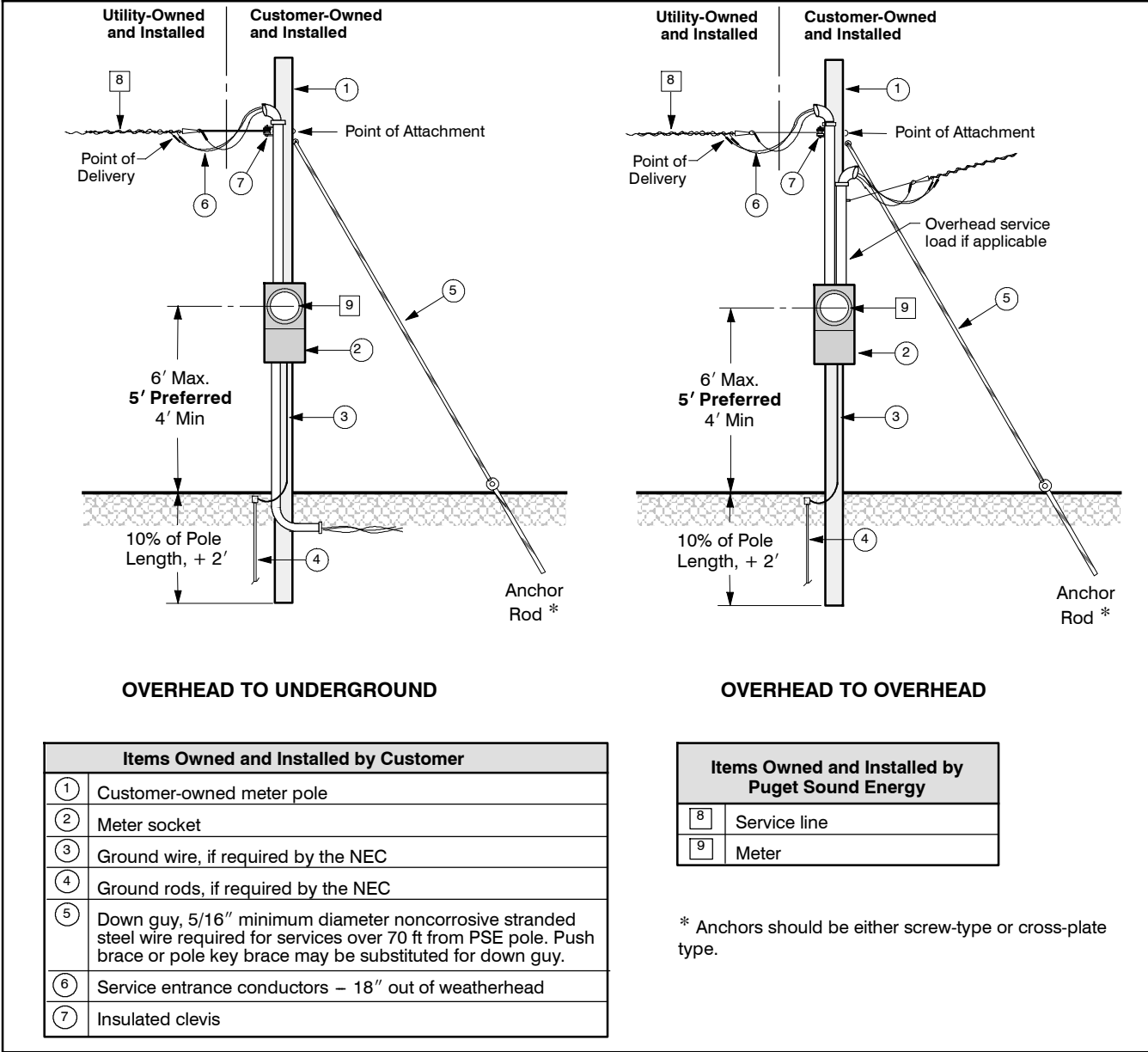
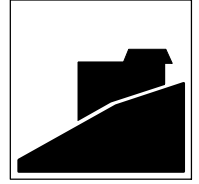

Figure 18 Permanent overhead meter pole installation



## Chapter 4



# Primary Line Extensions

---

If your new residence is not located close to existing primary electrical facilities, a primary line extension is required to place a transformer close to your structure. Primary line extensions are typically underground facilities.

---

### Customer responsibility

PSE's *Electric Tariff G, Schedule 85* requires customers to provide the trenching, excavation for vaults and **backfill** in accordance with PSE standards and work sketch, or contract with PSE to provide this work at its estimated cost.

If you require a primary line extension, submit *Electric Service Application Single-Family Residential 100E (Form 4414)*. All forms can be downloaded at **PSE.com**.

---

### Inspection/coordination

PSE shall assign a *Project Manager* to oversee the trenching, equipment placement/installation, and backfilling.

- Work shall be subject to the inspection and satisfaction of PSE.
- No work shall be backfilled, covered, or concealed until it has been inspected and approved by the inspector.

---

### Site preparation

The following site requirements must be met before the installation can begin.

- The trench route shall be clear of spoils, construction materials, and any other obstacles.
- The site shall be at final grade or acceptable subgrade in the area of construction.
- The front property line shall be surveyed and staked.

## Customer-provided trench

### Trench width

The minimum trench width is 18 inches. The excavator may need to increase the trench width depending on the other *conduits*/lines being installed in the trench.

When **increasing the trench width**, remember to allow adequate horizontal separation between PSE’s electrical conduits/cables, gas lines, and other utility-owned conduits and lines in the trench (see *Figure 19*).

Customer-owned facilities may not be in the same trench with PSE-owned gas lines.

PSE will allow customer-owned facilities within an electric power trench if the following minimum horizontal clearances from PSE electric facilities are maintained:

- 18 inches minimum for customer-owned tight-line sewer (not tile), storm drain lines, roof drain lines, natural gas line, propane gas line, fuel oil line, and water mains up to 6 inches.
- 12 inches minimum for **water services**, irrigation pipes, lighting, security and electric supply circuits, communication lines, closed-system roof drains/storm drains (not French drains), and culverts.

*Figure 19* illustrates PSE’s width and depth requirements for primary voltage cable residential line extension trenches on private property with and without a gas line present.

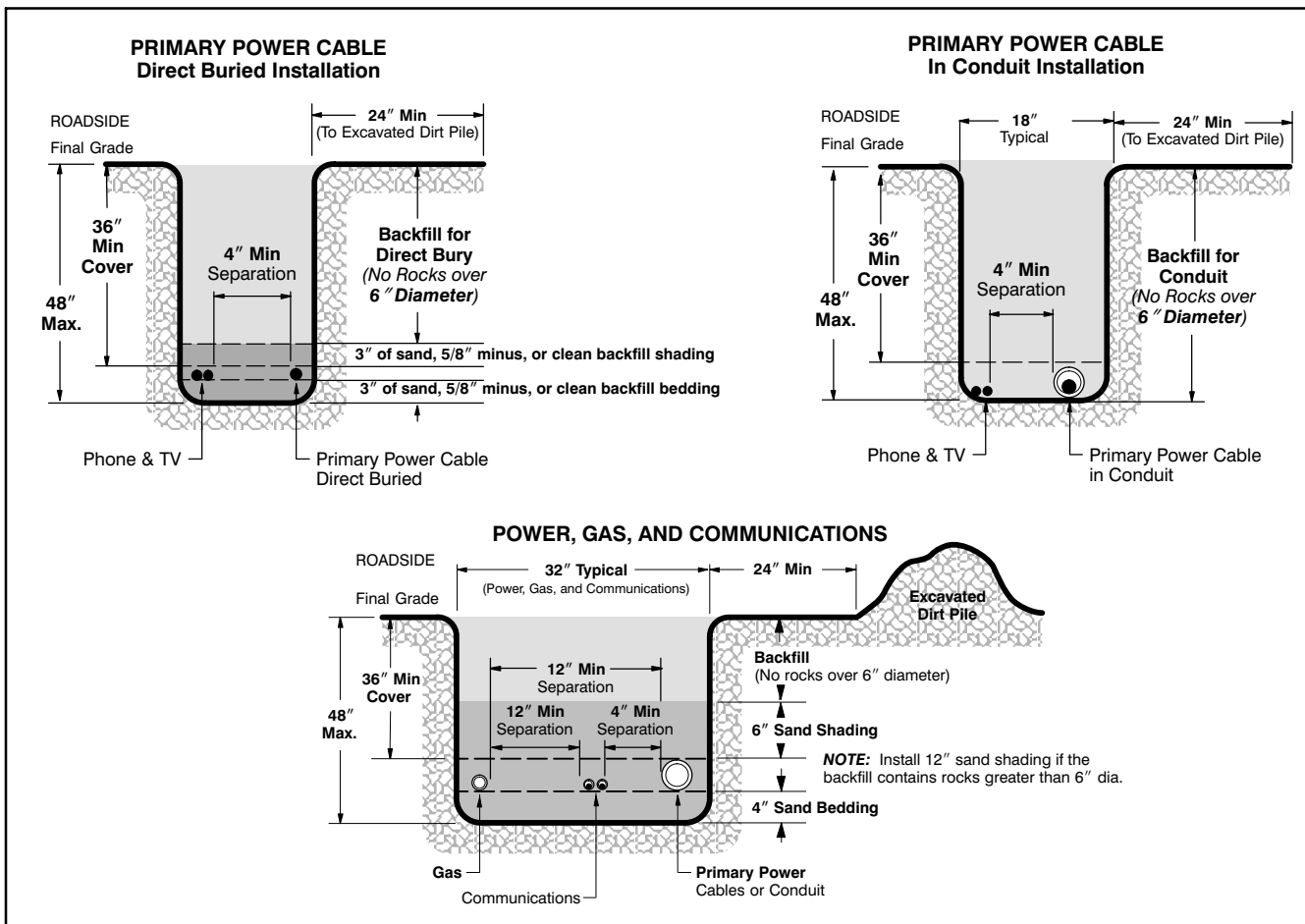

**Figure 19** Typical joint utility trench with primary voltage cable on your private property (cross-section view)

### Trench excavating requirements

The following requirements for the trench must be met before power conduits/cables will be installed.

- When you trench in right-of-way on PSE's behalf, the governing jurisdictions issue public roadway use permits to PSE.
- For trench work provided by you within a public right-of-way or a PSE easement, PSE requires that you use a Washington State licensed and bonded contractor and complete and sign a PSE trenching agreement form.
- Trench work within a public right-of-way must meet the erosion and sediment control requirements of the local jurisdiction.
- Provide a signed *Excavation Requirements & Final Grade Certification* document supplied by your *Project Manager* or *PSE Representative*.
- The trench shall be excavated according to the trench detail and PSE's work sketch.
- The trench shall be straight and the trench bottom shall be smooth, level, and free from obstructions, sharp objects, or rocks larger than 1/2 inches.
- Excavated or loose material shall be placed at least 2 feet from the field edge of the trench.
- Water shall be removed by pumping or draining following the erosion and sediment control requirements of the local jurisdiction.

**NOTE:** Trenches or vault excavations that are 4 feet deep or greater require special sloping. Contact your PSE *Project Manager* for these requirements.

### Trench and backfill requirements for electric

PSE **will not** energize its facilities until backfill is completed.

**You are responsible** for the following:

- Providing a minimum 3-inch layer of sand, 5/8-inch minus, or clean backfill (with rocks no larger than 5/8-inches and no sharp objects) placed below and above direct buried cables. The remaining trench shall be backfilled with soil that is free of rocks larger than 6 inches and foreign objects.
- If the cable is in conduit, backfill the trench with soil that is free of foreign objects and rocks larger than 6 inches. Bedding and shading with a 3-inch layer of sand, 5/8-inch minus, or clean backfill is not required.

**Trench and backfill requirements if a natural gas line is in the trench**

You must provide a 6-inch or 12-inch layer of sand above (depending on the backfill soil conditions), and a 4-inch layer of sand bedding below the utilities before backfilling (see *Figure 19*).

**You are responsible** for the following:

- Completing backfill as soon as practical after facilities are placed and inspected.
- Carefully placing backfill to prevent damage or movement of the cables or conduit.
- Cost of damages to PSE facilities caused by improper backfill or compaction.
- Relocation costs due to change in grade or alignment.

*CAUTION: Do not use a compactor directly over the power conduit(s) until at least 30 inches of backfill is in place, so that the compactor will not damage the cables or conduit. Do not penetrate the soil deeper than 3 inches during compaction with a backhoe compactor.*

---

**Vaults**

PSE is responsible for furnishing and installing all primary vaults required for your electric service.

**Vault excavation procedure**

1. Locate the vault according to PSE's work sketch drawing.
2. Determine a suitable place to put the spoils (at least 2 feet from the edge of the excavation).
3. Excavate so the vault is in correct alignment with the trench and so that conduits for primary voltage cables (if required) can be brought straight into the front half of the vault.
4. Dig a hole large enough to accommodate the transformer or junction box vault and allow for easy installation and compaction (see *Figures 20* through *22*).
5. Remove debris and level the bottom of the excavation.
6. Prepare the bottom of the excavation so that the vault will rest on solid undisturbed earth with a 6-inch base of crushed rock. This prevents vault settling.

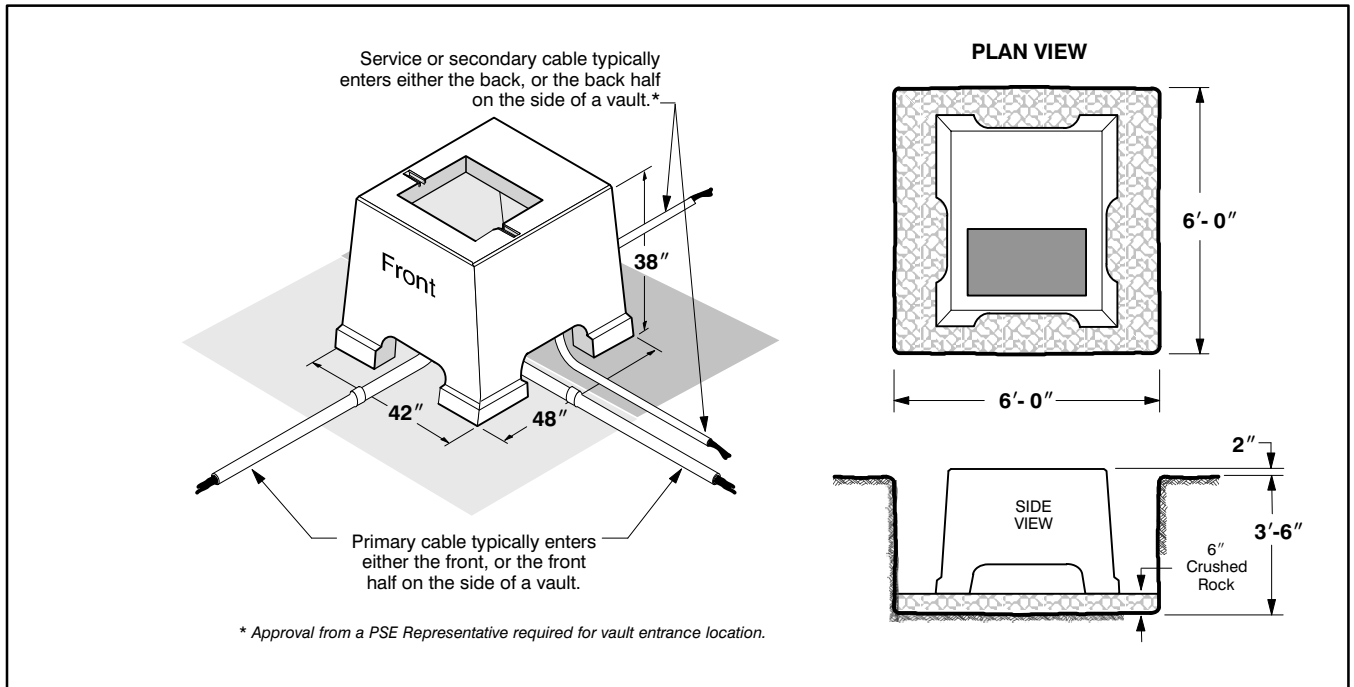

Figure 20 Padmount transformer vault excavation

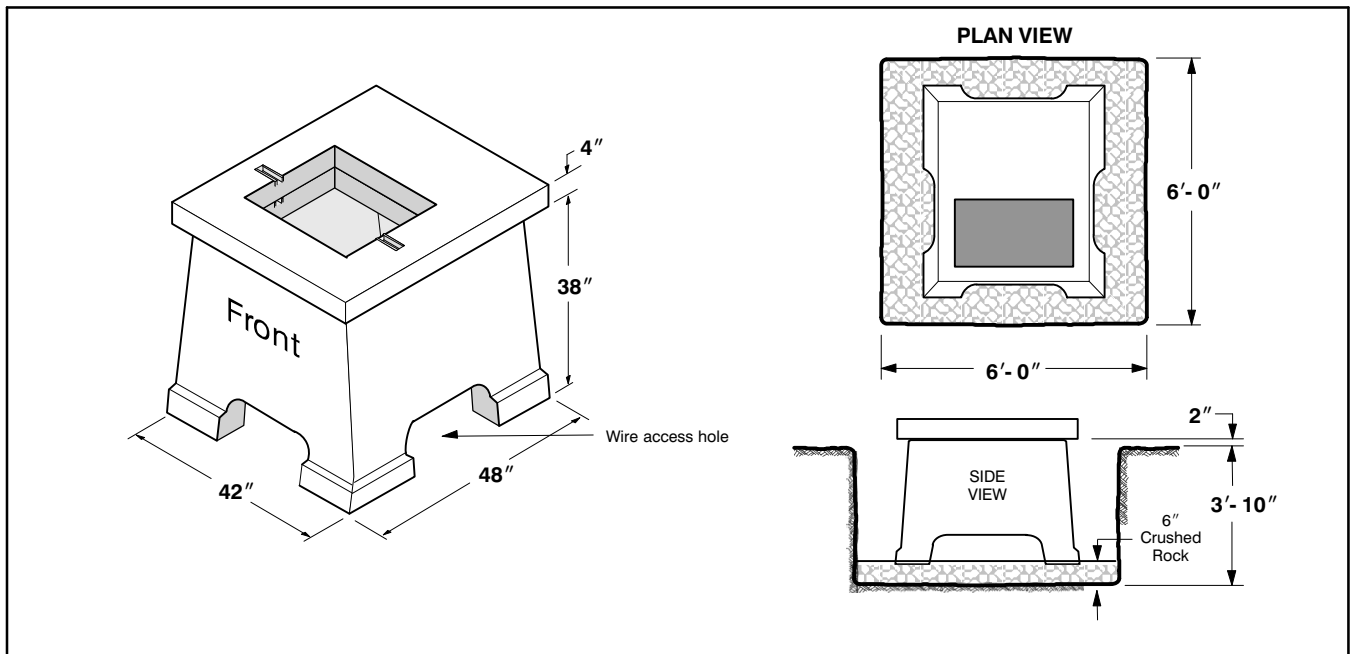
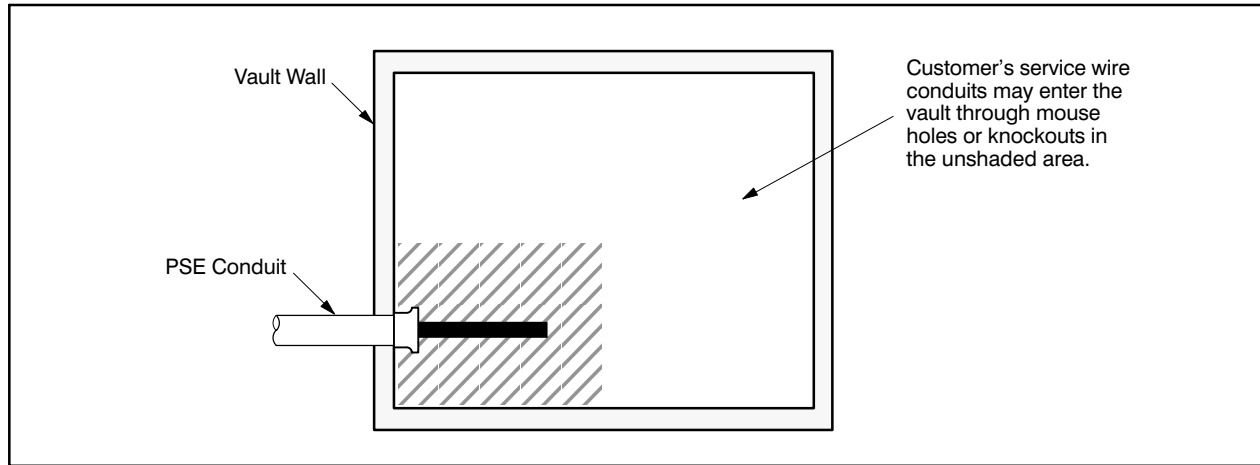

Figure 21 Aboveground junction box vault excavation



**Figure 22** Location of customer conduit in PSE vaults

### Vault location and access

Underground equipment must be readily accessible by workers and equipment during construction and for future operation and maintenance. Workers should not have to climb over or remove obstacles to gain access. Heavy construction equipment must be able to get close enough to the excavation to place the vault in the hole. Consider the underground equipment's weight and the lifting angle and swinging radius of the boom truck when choosing the underground equipment's location. Remember that dump trucks may need access if select fill is used for fill or if excavated material will be hauled away.

A clear and level working space is necessary for the operation and maintenance of Underground Equipment. The location must allow room to operate a switch handle, completely open a hinged steel door, or use a hotstick to install and operate equipment. In no case shall clearances be less than those required by code from combustible and noncombustible walls, bodies of water, fire escapes, etc.

The working space should be free from obstructions such as trees, shrubbery, poles, buildings, retaining walls, structures, fences, fire hydrants, decorative screens, ditches, streams, roadways, etc. Consider possible future structures and equipment which could interfere with clearances and accessibility.

### Vault backfill material

Backfill around vaults should consist of good compactable material such as clean earth fill, crushed rock, or sand. No voids should remain between the vault walls and the sides of the excavation.

Backfill beneath the vault shall be crushed rock, six inches deep to stabilize the vault.

If the vault is located in a concrete drive or sidewalk, a felt joint is to be installed around its perimeter.

## Continuous conduit systems

When PSE's design includes a continuous conduit system, PSE will supply conduit for primary voltage cables.

---

## Customer-supplied conduits

You may supply and install discontinuous primary conduit for construction convenience.

If you supply the conduit for primary voltage cable, it will be owned and maintained by PSE and shall meet the following specifications:

- PVC electrical grade, Schedule 40 (or Schedule 80 if required in poor soil conditions).
  - Gray in color.
  - 2-, 3-, 4-, or 6-inch diameters as specified on the work sketch.
  - Conduit bends shall be long radius bends, 36-inch minimum radius.
  - Meet requirements in ASTM F 512 and NEMA TC 2.
- 

## Terminating conduit at transformer

- When installing the conduit, stop 2 feet short of the entrance into the wire access hole located at the bottom of the mini pad transformer handhole.



## Chapter 5

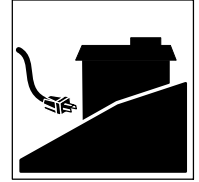

# Meter Installation

This chapter provides you with PSE's requirements for the metering equipment that you must provide to hook up your new service. Please follow these requirements to avoid a delay in your service hookup. If you have any questions about this information, call your *Customer Construction Services (CCS) Representative*.

## Service rating options

PSE's metering equipment requirements for single-family residential structures (not apartments or condominiums) are based upon the following single-phase service ratings:

Voltage	Ampere Rating
120/240	200 A
120/240	400 A
120/240	over 400 A *

\* If you need a three-phase service, please contact your *CCS Representative*. Such services require the approval of PSE's Meter Department, and are not covered in this handbook.

## Responsibilities

### Puget Sound Energy

PSE is responsible for installing the meter, service line, and current transformer (CT).

### Customer

**You are responsible** for providing and installing all service entrance equipment (including the meter base/socket and CT enclosure).

## Meter bases/sockets

### General requirements

The meter base/socket you purchase and install shall meet the following general requirements:

- Be a ring-type socket that includes a screw-type, stainless steel, or aluminum meter ring (snap-type rings must be stainless steel).
- Be Underwriters Laboratories (*UL*) approved.
- Be rated for exterior use and be rain-tight according to NEMA-3R.
- Have all unused openings tightly sealed from the inside of the socket.
- Be plumb and securely fastened to the supporting structure.
- Have a cover that is securely attached to the meter base/socket case.

**NOTE:** Meter base/socket and current transformer enclosures shall not be used as a junction box.

### Meter base/socket location

For single-family residences and manufactured and mobile homes, you are required to install your meter base/socket in a place that is accessible to PSE. All locations are subject to approval by a *PSE Representative*. If you have questions regarding meter locations, call your *CCS Representative*.

Meter bases/sockets and CT enclosures must be located:

- Outside.
- On the front one-third of your home closest to normal public access.
- In an area that is **not** subject to being fenced or walled in (such as patios, decks, porches, breezeways, backyards, and carports).
- On a structure that is owned by you.

These locations allow PSE to:

- Read your meter in a cost-effective manner.
- Maintain your meter efficiently.
- Disconnect your service in case of fire.

### Grounding requirements

All meter bases/sockets, enclosures, and conduit shall be bonded and grounded in accordance with the NEC.

---

### Clearance requirements for meter installations

The following clearances are required around all meter installations. It is your responsibility to provide and maintain these clearances.

- The center of the meter shall be between 4 and 6 feet above finished grade (except meter pedestals)—**5 feet is preferred**.
- A working space of 36-inches wide by 36-inches deep (see *Figure 23*) is required around the meter. This working space is to be kept clear of any obstructions including landscaping.
- There shall be a minimum horizontal and vertical clearance of 10 inches between the center of the electric meter and any obstruction (see *Figure 23*).
- If a recessed meter bases/socket is installed, a 10-inch clearance is required from the meter to the closest portion of the wall (see *Figure 24*).
- If a flush or recessed meter base/socket is installed, the siding or finished surface of the structure shall not overlap the cover of the meter base/socket.
- If a flush or recessed meter base/socket is installed, space must be left around the locking tab for PSE to install a meter seal.

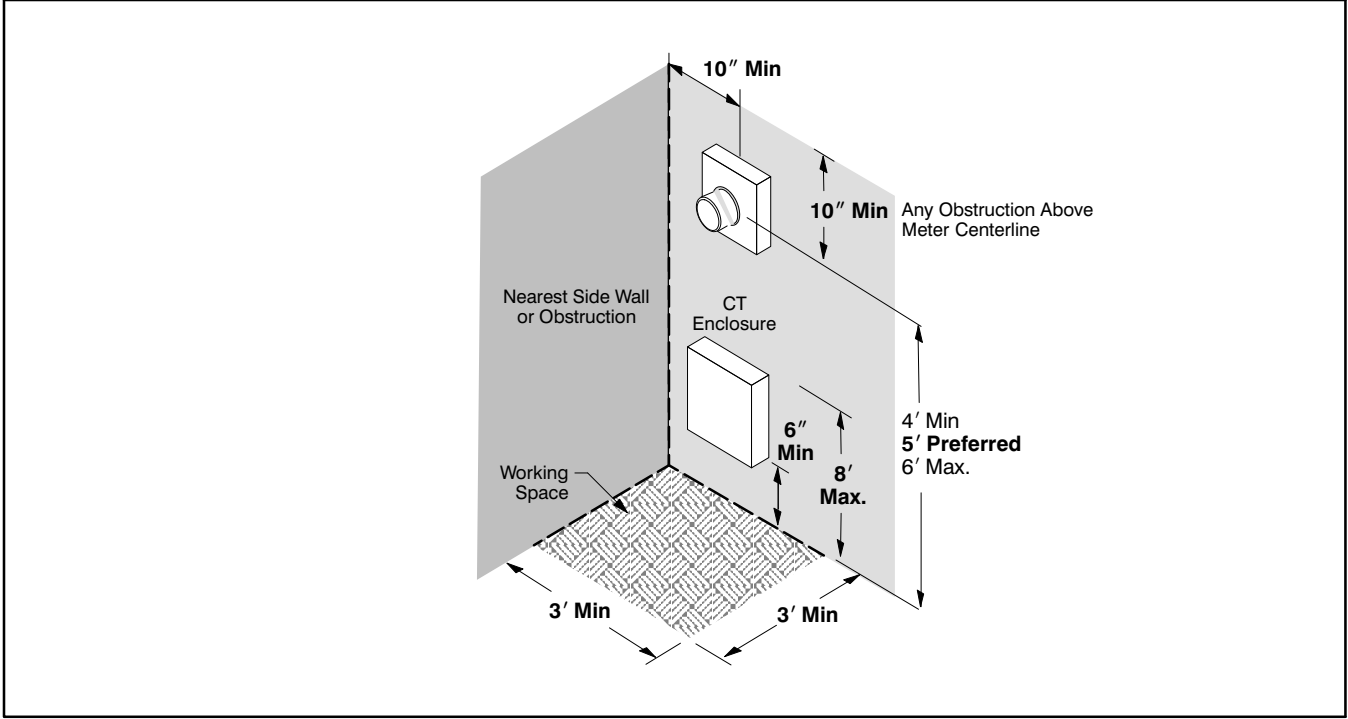

Figure 23 Meter base/socket minimum clearances

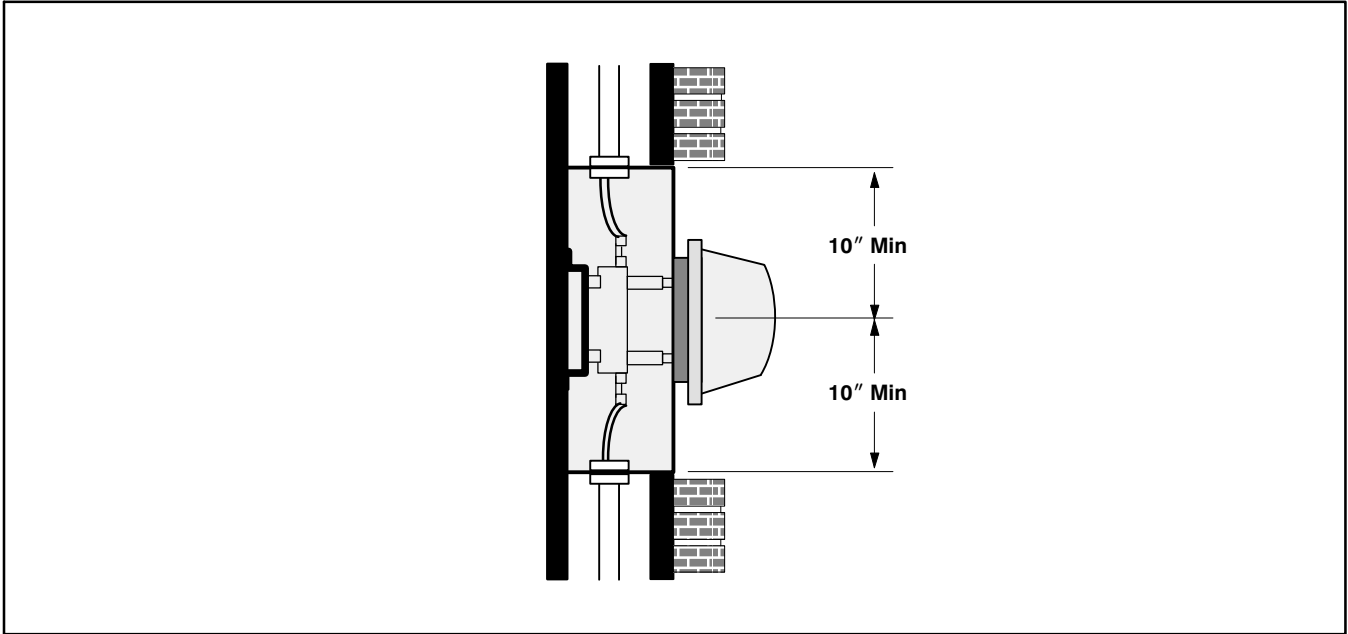

Figure 24 Recessed meter installation clearances

## 200 A services

### Single-family residential

The 120/240 V, 200 A service is the most common service installed by PSE. Typically, it is installed on homes with a living area of less than 2,500 square feet. However, depending upon what type of equipment you are installing, you may want a larger service. It is your responsibility to determine your electrical requirements and to notify PSE of the size of service you would like. Refer to *Chapter 1, Table 3*, for service size information.

### Underground

In addition to the meter base/socket requirements earlier in this chapter, meter bases/sockets for 200 A underground services shall:

- Be rated for 120/240 V and 200 A.
- Contain four *meter jaws* and one connection point for the *neutral* conductor.
- Be at least 4-1/4 inches deep, 11 inches wide, and 14 inches high.
- Accept 2-inch steel or 2-1/2-inch PVC conduit.
- Have lugs (electrical connectors) that are marked to accept 4/0 aluminum conductors.

**NOTE:** Use only the conduit knockouts on either side of the bottom of the meter base/socket enclosure for PSE's service cable.

### Overhead

In addition to the meter base/socket requirements earlier in this chapter, meter base/sockets for 200 A overhead services shall:

- Be rated for 120/240 V and 200 A.
- Contain four meter jaws and one connection point for the neutral conductor.

### Outbuildings (overhead or underground service)

Meter bases/sockets for 200 A (or less) services to **single-family residential use** outbuildings (such as garages, shops, single-family wells, or noncommercial barns) must meet all the requirements listed in this chapter for either underground or overhead services.

**NOTE:** If outbuilding/s is used for a commercial operations please refer to PSE's *Electric Service Handbook, Commercial/Industrial and Multifamily Projects* as you will have additional requirements including customer-provided service conductor and a manual bypass meter base/socket.

---

## 400 amp services

The meter base/socket required for a 120/240 V, 400 A service is called a Class 320 meter base/socket (see *Figure 25* and *26*). It is larger than the 200 A meter base/socket, but it is still a *self-contained* meter base/socket. It can be installed on residences where the continuous current rating is 320 A or less.

**NOTE:** If your structure requires more than 320 A of continuous current, you are required to install a CT service, refer to the *400 A current transformer (CT) services* section in this chapter.

## Underground

In addition to the meter base/socket requirements listed earlier in this chapter, Class 320 meter bases/sockets for 400 A underground services shall:

- Be rated for 120/240 V and 320 A continuous current.
- Contain four meter jaws and one connection point for the *neutral* conductor.
- Contain a Class 320 *manual block bypass* (see *Figure 25*).
- Have lugs that will accept 350 MCM aluminum wire.
- Accept 3-inch steel or Schedule 40 or 80 conduit through a knockout in the bottom left corner or center of the *enclosure*.
- Have at least an 8-1/2-inch clearance between the bottom of the lugs and the bottom of the enclosure (see *Figure 25*).

## Overhead

In addition to the meter base/socket requirements listed earlier in this chapter, Class 320 meter bases/sockets for 400 A overhead services shall:

- Be rated for 120/240 V and 320 A continuous current.
- Contain four meter jaws and one connection point for the neutral conductor (see *Figure 26*).
- Contain a Class 320 manual block bypass.

## Outbuildings (overhead or underground service)

The metering requirements for 400 A services to outbuildings are the same as the metering requirements for 400 A services to single-family residential structures.

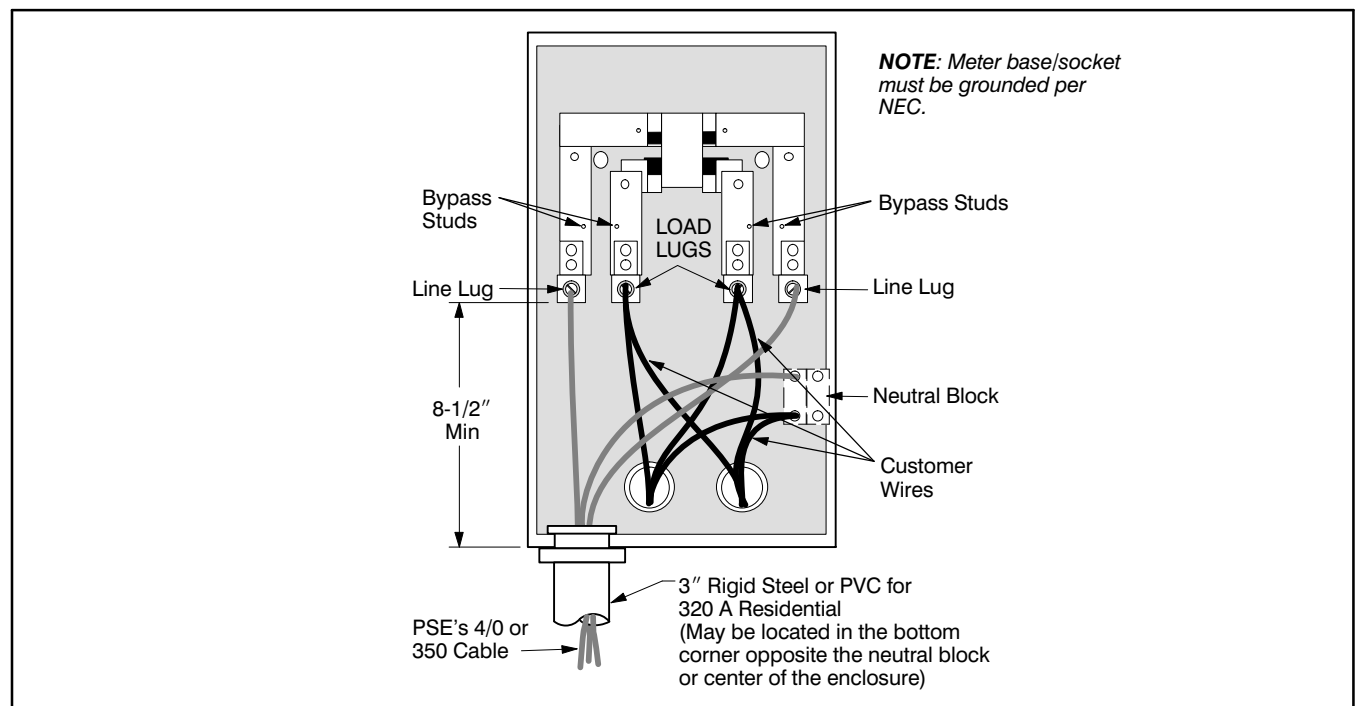

**Figure 25** Typical arrangement of service conductors for underground class 320 meter base/socket

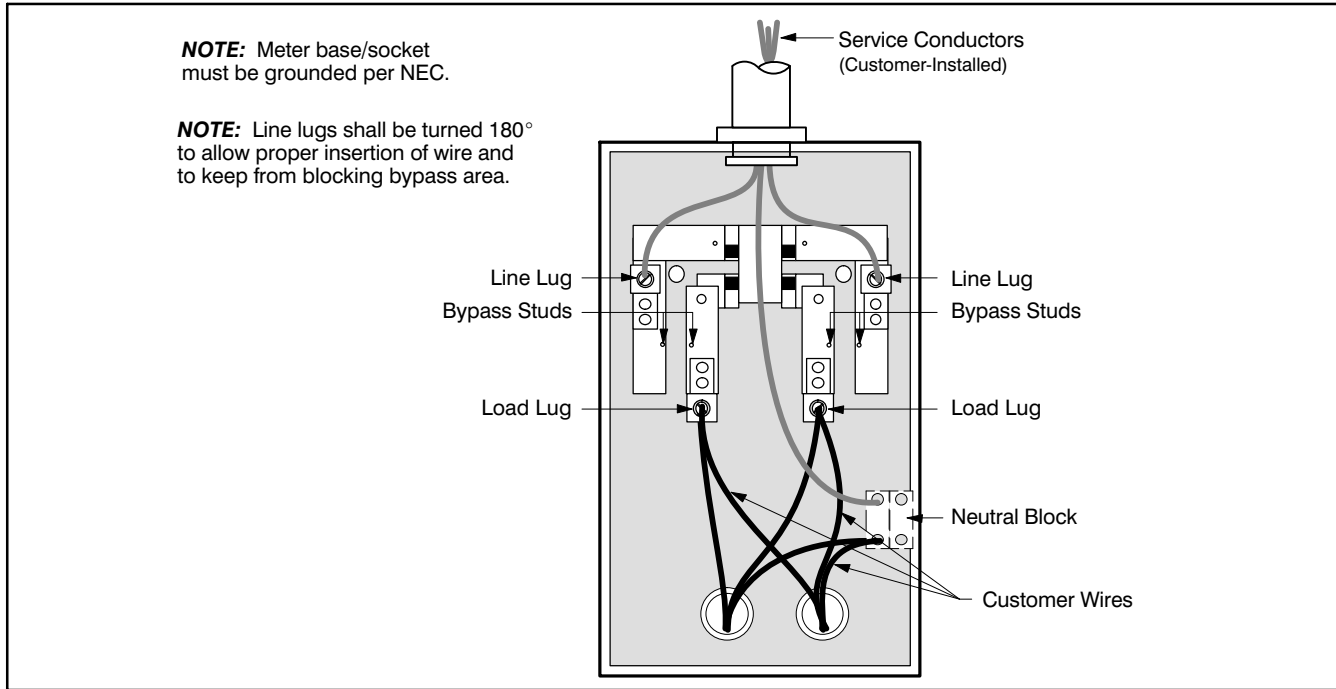
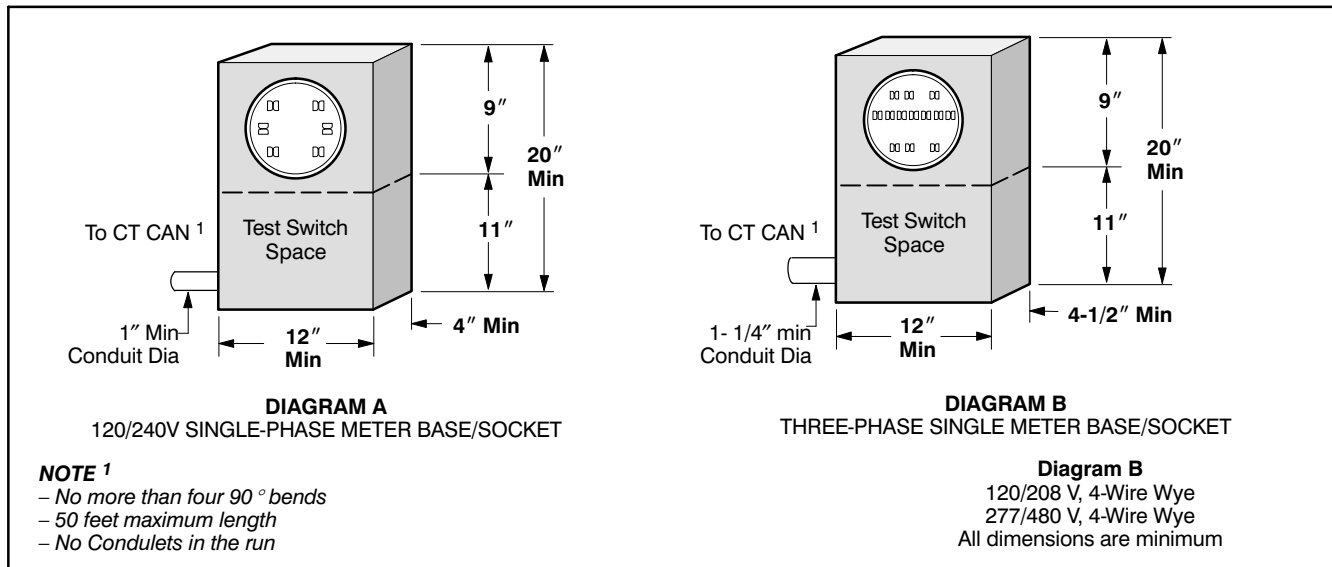

**Figure 26** Typical arrangement of service conductors for overhead class 320 meter base/socket

### 400 A current transformer (CT) services

120/240 V, 400 A CT services are available at an additional charge. This service requires a different meter base (see *Figure 27*). It also requires additional equipment (CT enclosure, conduit, CT mounting bracket, etc.). The CT enclosure must be located on the outside of the structure that it serves. Contact your *CCS Representative* for more information.

**NOTE:** The CT enclosure cannot be used as a junction box or bus gutter.



**Figure 27** Instrument-rated (CT) meter bases/sockets

### Services over 400 A

All 120/240 V services over 400 A (320 A continuous current) require CT metering. *Figure 28* shows a CT mounting base. Please contact your *CCS Representative* for more information. *Table 7* describes minimum CT enclosure dimensions.

**Table 7** CT enclosure dimensions (minimum)

Phase	Switch Ampacity	No. of Transformers	Width	Height	Depth
1 *	400-800	2	24"	48"	11"
3 *	201-800	3	36"	48"	11"
3 †	over 800	3	†		

\* Enclosure with a side-opening single-hinged door is required when cabinet dimension is larger than 24 in. x 48 in.  
 † Services over 800 A require a switchboard designed to **EUSERC** specifications. Services from 201-800 A may be switchboard designed to EUSERC specifications.

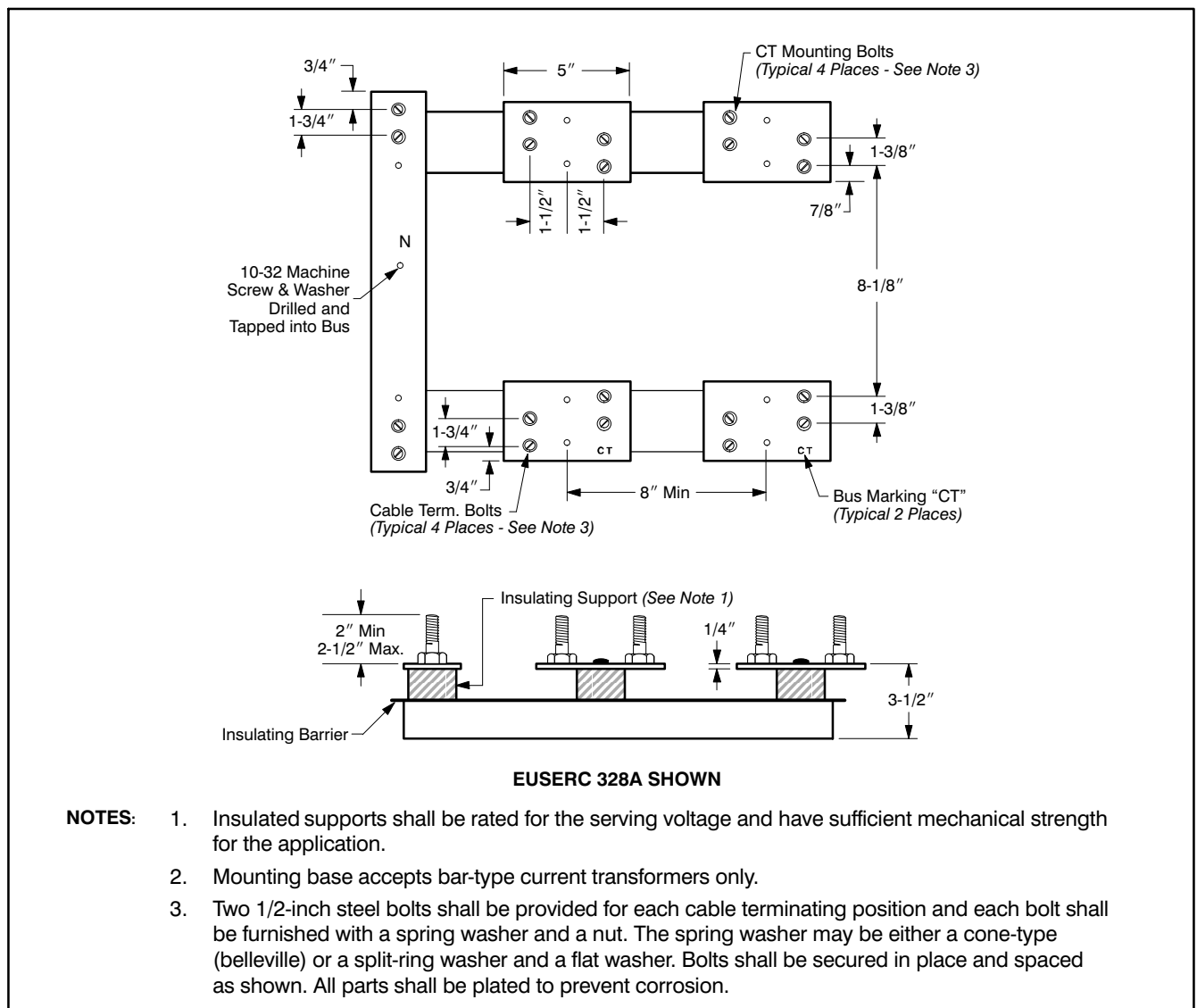

**Figure 28** Single-phase CT mounting base



## Chapter 6

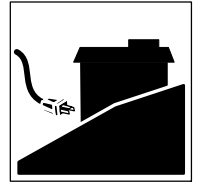

# Temporary Services

## What this chapter contains

In this chapter you will find answers to questions such as:

- What are the installation requirements for underground and overhead service?
- What are the trenching requirements?
- How do I locate existing underground utilities before I dig?
- How do I get my temporary service energized?

## Definition

**A temporary (temp) service is a means of supplying electricity to your site for less than one year.** Typically, a temporary service provides power for the construction phase of your project, while provisions are being made for your permanent power system. Temp service is provided underground or overhead depending on available PSE facilities.

## Obtaining your temporary service from existing power facilities

The following information applies to your temporary service installation:

- Determine if you need overhead or underground service (see *Preface, Figure 1*).
- Call PSE and establish an account with PSE and place your temporary service order.
- Obtain an electrical work permit.
- Order underground utility locate service by calling 811, at least two working days before you dig, or via the web (click ITIC at [callbeforeyoudig.org](http://callbeforeyoudig.org)).
- Prepare the job site and install your temp service equipment (service post, pedestal, and meter base per illustrations found in this chapter).
- Obtain an electrical inspection approval of your temp service equipment (this is done by you or your contractor).
- Call PSE to request that your temp service be connected and energized after your electrical inspection is complete.
- Apply for permanent service.
- At your request, we will check your site to determine if engineering is required.

If you have any questions, please call **Customer Construction Services (CCS)** at **1-888-321-7779**. For information on permanent services, please contact CCS.

## Scheduling

Most temp services are connected to existing power facilities and engineering is not required. In these cases temp services are typically energized 3 to 5 days after your installation has passed inspection. Depending on complexity and work volume, time frames will vary.

---

## Customer charge for service

Charges vary due to the type of system we have in your area. Your *CCS Representative* will explain current temp service fees.

---

## Temporary meter base/socket requirements

You are required to provide a meter socket with the following specifications:

- A ring-type socket that includes a screw-type, stainless steel, or aluminum meter ring (snap-type rings must be stainless steel).
- Rated 120/240 V
- Single-phase
- Minimum rating of 100 A
- Maximum rating of 200 A
- Four jaws
- Underwriters Laboratory (*UL*) *approved*

---

## Temporary underground services

Temporary underground service is available in PSE's service area where the existing power facilities are installed underground.

The process and cost of obtaining your temporary underground service can vary, depending on the location of our existing facilities. If there is a power stubout, handhole, pedestal, or transformer located on your property *adjacent to our existing facilities* (see *Preface, Figure 1*), engineering may not be required. Simply install your temporary service facilities (see *Figure 29 and Figure 30*), obtain an electrical inspection, and call PSE to connect your temporary service.

## Meter location

To properly locate your temporary meter pedestal, set the meter pedestal on your property no more than 5 feet from the transformer, stubout, handhole, or pedestal.

Sometimes a distance greater than 5 feet is required such as when your home site is some distance from our existing facilities and you want your pedestal close to where your permanent service will be located. In this case, please contact a *CCS Representative* at **1-888-321-7779** for information on setting up a remote temporary underground service.

## Trenching and excavation requirements

It is the **customer's responsibility** to provide the trenching needed to connect to a power stubout (shown in *Figure 29*). The cable you provide is to be sized according to the NEC and have a minimum 24 inches of backfill coverage.

**NOTE:** A 4-foot-square excavation is required at the stubout to provide working room for our personnel to splice your cable to ours.

If the connection point to PSE facilities is a handhole, pedestal, or transformer; trench up to the nearest side and leave your wires exposed. If you discover any other conductors while digging your trench, please leave them covered.

Remember to order underground utility locate service by calling 811, at least two working days before you dig, or via the web (click ITIC at [callbeforeyoudig.org](http://callbeforeyoudig.org)).

**NOTE:** Any trenching within 24 inches of existing underground facilities, must be done by hand.

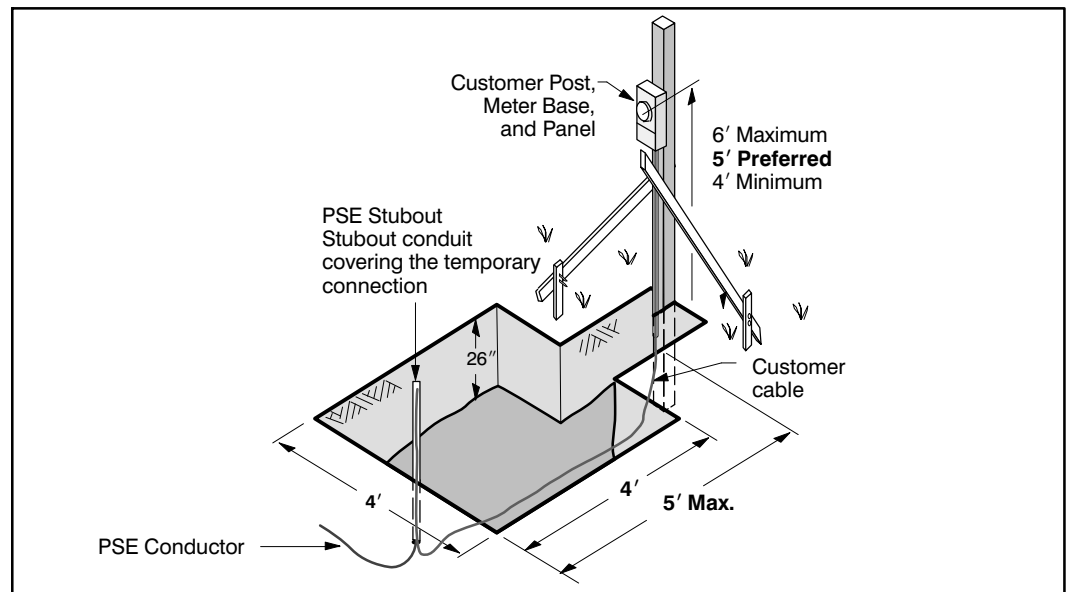

**Figure 29** Trenching requirements for power stubout

## Underground temporary service installation process

The following items must be completed before PSE energizes your underground temporary service:

1. Contact a *CCS Representative* at **1-888-321-7779**, and request your temporary underground service.
2. Obtain an electrical work permit from the inspecting agency.
3. Order underground utility locate service by calling 811, at least two working days before you dig, or via the web (click ITIC at [callbeforeyoudig.org](http://callbeforeyoudig.org)).
4. Install your meter pedestal and meter base/socket in the appropriate location (see *Figures 29 and 30*).
5. Provide the appropriately sized conductor from your meter socket to PSE's connection point. Please leave 5 feet of extra cable at the stubout or handhole, and 10 extra feet at a transformer. Consult the NEC for the appropriate cable sizes.
6. Obtain and pass an electrical inspection.
7. Trench up to and expose the PSE connection point at the stubout, handhole, or transformer.
8. If trenching is provided, cover your cable except in the work pit where our personnel will be splicing your cable to ours.
9. After the above items are complete, call CCS at **1-888-321-7779** and inform a *CCS Representative* that your installation has been inspected and that you are ready for your temporary service.

*Figure 30* shows the standard temporary underground service installation that we recommend. The dimensions shown are the minimum acceptable.

**Please do not deviate from our installation standards without approval from your CCS Representative.** Doing so may extend the time frame for your service hookup.

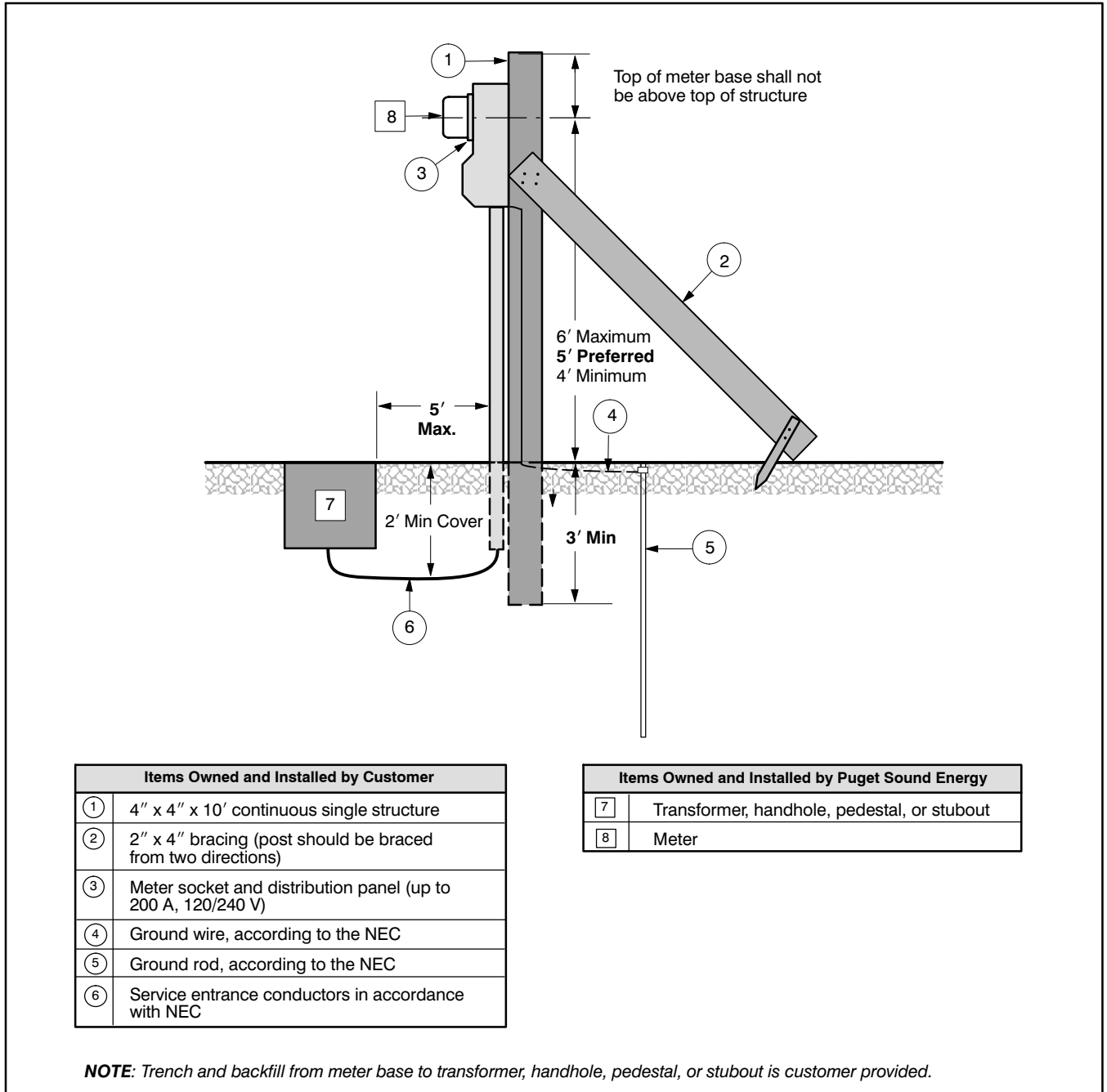

**Figure 30** Temporary underground service installation

## Temporary overhead services

Temporary overhead service is available anywhere in PSE's service area where the existing electrical system is installed overhead.

The process and cost of obtaining your temp overhead service can vary depending on the location of our existing facilities. The least complicated and cheapest way a temp service can be installed is if a transformer is located on a pole alongside your property (see *Preface, Figure 2*). If this is the case, engineering may not be required. All you have to do is install your temp service equipment, have it inspected, and call **Customer Construction Services (CCS)** at **1-888-321-7779** to order your service. Once the above items are completed, your service will be connected within a few business days.

## Meter location

Your temporary meter post should be located on your property and within 70 feet of the PSE pole that will serve you. This limitation ensures that your temporary service pole can withstand the weight of the conductor. If a distance greater than 70 feet is required, or if PSE's pole is on the opposite side of the street, please call CCS for our review and approval **prior to construction**. A taller, stouter temporary service post with additional bracing could be required.

## Service line path requirements

In addition to the meter post distance limitation mentioned above, please consider the service line path requirements:

- The path that the service line will take should not cross property belonging to other individuals.
- If the service line will pass through trees or brush, clear a path to allow our service personnel to run the line and to allow the lines to hang without contacting trees or limbs. Maintaining this clear path is the **customer's responsibility**.
- The service line path should avoid areas where vehicular traffic will occur, unless your temporary service post height is increased to provide adequate **clearance** (see *Figure 31*).

## Clearance requirements

The National Electric Code (NEC) and the National Electric Safety Code (NESC) have established minimum clearance requirements to maintain safe heights for electrical conductors over various terrains.

*Figure 31* shows the clearance requirements for the types of terrain most commonly encountered.

The NEC and NESC require the lowest point of a service conductor to be at least 12 feet aboveground. The bottom of the **drip loop** must be a minimum of 10 feet above the ground.

**You are required** to provide a **point of attachment** on your service pole that will allow PSE to install the conductor and maintain the required clearances.

If you need further details, please consult the current issue of the NEC, or contact the state or local electrical inspector for your area.

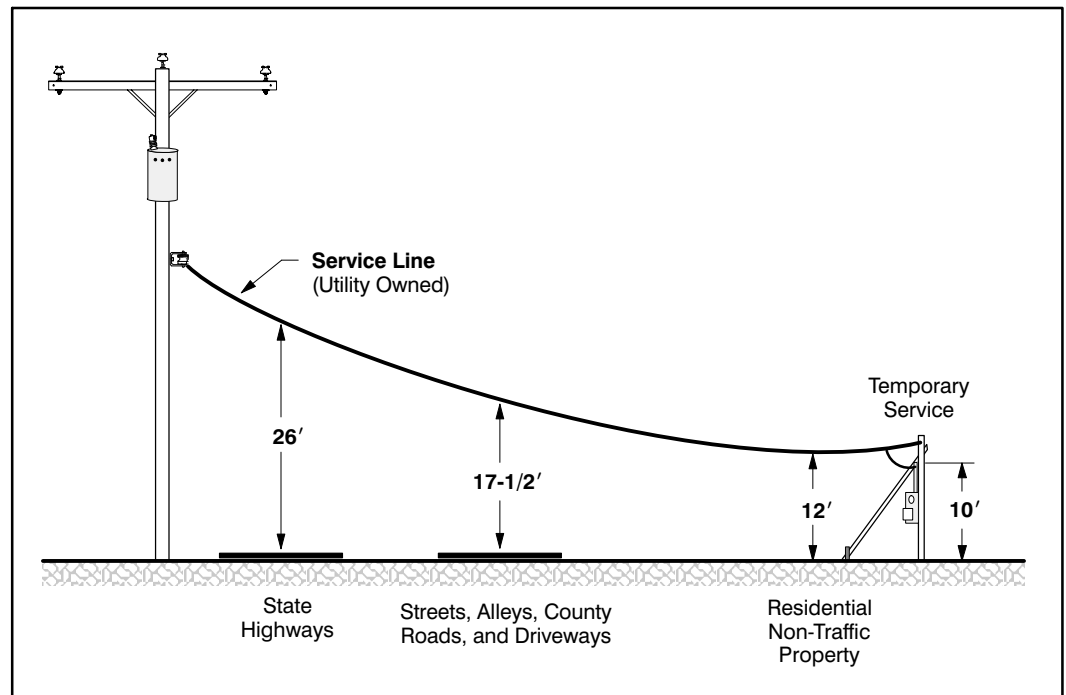

**Figure 31** Minimum clearance requirements upon installation

### Overhead temporary service installation process

The following items must be completed before we can energize your service:

1. Contact a *CCS Representative* and request your temporary underground service.
2. Obtain an electrical work permit from the inspecting agency.
3. Install a *meter pole* and meter socket.
4. Obtain and pass an electrical inspection.
5. After these items are completed, call CCS and inform a *CCS Representative* at **1-888-321-7779** that your installation has been inspected and that you are ready for temporary service.

*Figure 32* shows the standard temporary overhead service installation that we recommend. The dimensions shown are the minimum acceptable.

This installation shows a safe temporary service. **Do not deviate from the installation standards without approval from your CCS Representative.** Doing so may extend the time frame for your service hookup.

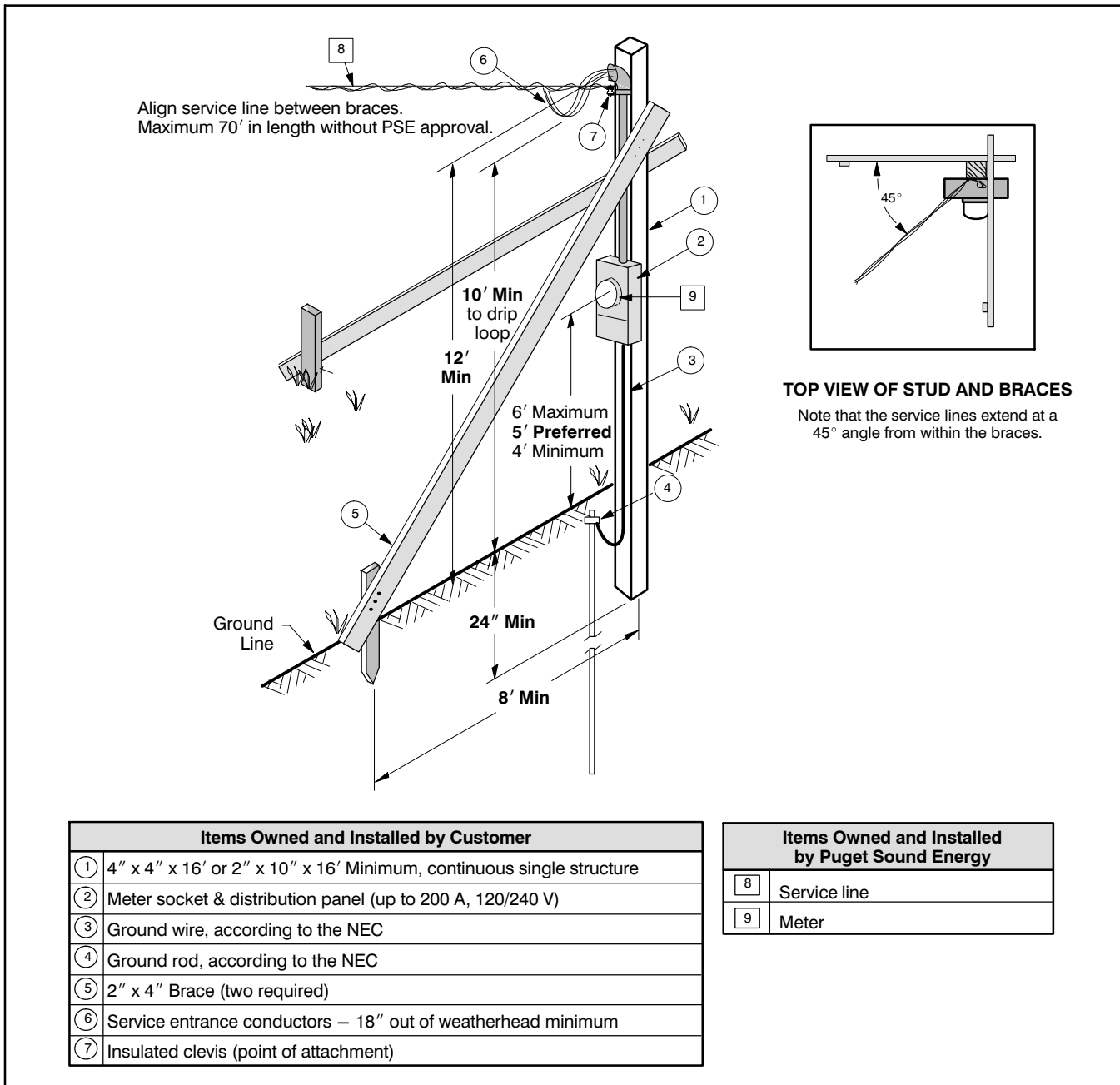

Figure 32 Temporary overhead service installation

## Chapter 7



# Disconnection and Modification of Service

There may be a time when your electric service needs to be modified. You may wish to have your service disconnected, reconnected, moved from its current location, relocated, or simply de-energized. This may involve lengthening, shortening, transferring, or rerouting the existing service.

## Disconnection of your meter

If you need the power disconnected to work on your side of the meter, without actually removing the wire from the insulator, PSE will perform a simple disconnect/reconnect service for you.

PSE defines a “disconnection” as the disconnection or reconnection of single-phase, self-contained meters or service lines at the meter base or weatherhead for the convenience of the customer.

If the wire has to be removed, relocated, or otherwise manipulated as this becomes a modified service (refer to the *Modified services* section below). Check with your *CCS Representative* to verify any charges that you may incur.

## Modified services

PSE classifies work done on a service as a “modified service” when a customer requests a change in their secondary service that alters its current *point of delivery* or location to a new point of delivery without requiring the replacement of the entire service entrance conductor.

A modified service still must meet all the new service installation requirements. You are responsible for equipment from the meter socket into your building.

An electrical work permit must be present on your property for all work done on the customer side of the meter. You must apply for the permit before the work is started. After the work is completed, your local government agency must inspect the work before PSE can energize the service.

We know at times the electrical inspection is not completed or feasible by the time we arrive to reconnect your service. For modified services, if the permit is present and the work is completed, but the inspection has not been done, the service may still be energized by PSE if the work looks safe, clean, and completed. The inspection can take place the following day.

The customer requesting a modified service shall be required to pay PSE the costs of altering, transferring, or extending the existing electric service to the new point of delivery or location.

Modified service requirements can vary depending on the scope of the change (see *Table 8*).

**Table 8** Example of overhead and underground modified service

Customer Request	PSE and Customer Responsibilities
<p><b>Overhead Modified Service</b> Your electric meter base is being replaced with a new meter base, and will be located a few feet away from where old meter base was. You will also replace the existing mast and weatherhead.</p>	<ul style="list-style-type: none"> <li>■ Notify your <i>CCS Representative</i> if you are changing panel amperage rating or increasing the connected load within your building.</li> <li>■ You or your electrician must arrange for PSE to remove the wire from the point of attachment and make permanent connection to the new weatherhead. You must give PSE adequate notice of your intentions, typically 5 to 10 working days prior to needing your service energized.</li> <li>■ An electrical permit must be present and visible prior to PSE energizing your service.</li> </ul>
<p><b>Underground Modified Service</b> Your mobile home is being relocated and you need to move your meter pedestal closer to the new location. Or, you are remodeling and have to change the electrical panel and/or meter location.</p>	<ul style="list-style-type: none"> <li>■ Notify your <i>CCS Representative</i> if you are increasing the load or capacity of your meter panel.</li> <li>■ <b>You are responsible</b> for digging to the new pedestal location.</li> <li>■ You must expose PSE's wire or conduit at the old pedestal location. This is where your new trench will start.</li> <li>■ A new pedestal installation permit must be present and visible on-site prior to calling PSE to perform the work. You must give PSE 5 to 10 working days notice prior to calling PSE to perform the work.</li> </ul>

---

## Glossary

---



**Approved** - Acceptable to the authority having jurisdiction.

**Backfill** - Native soil or soil brought in from another area, free from sharp objects, rocks, scrap building material, and corrosive material.

**Clearance** - A set distance between two objects.

**Conduit** - A listed or approved wireway with a smooth interior surface to permit easy drawing-in of the electrical conductors. A conduit may be metallic or nonmetallic, depending on its usage, in accordance with codes and Puget Sound Energy Standards.

**Customer Construction Services (CCS) Representative** - The designated representative of Puget Sound Energy, responsible for design and/or coordination of new or revised services to PSE customers. The CCS Representative responds to inquiries on policies, standards, practices, rates, and energy utilization.

**Demand** - The maximum average kilowatt load used by the customer for a specific period of time during the billing period.

**Direct Burial** - The installation of electrical conductors in a trench, without the use of conduit.

**Drip Loop** - A loop formed in overhead secondary conductors at the weatherhead to prevent water from entering into the service entrance conduit and equipment.

**Enclosure** - A sealable cabinet designed for surface or flush mounting, and provided with a frame or trim in which doors or removable covers are hung.

**EUSERC** - Electrical Utility Service Equipment Requirements Committee

**Guy** - Cable or brace used to relieve the strain of overhead conductors on masts and poles.

**Manual Block Bypass (Circuit-Closing Block)** - A provision for paralleling the meter circuit, allowing the meter to be removed without interrupting service to the customer.

**Meter Jaw** - A spring-loaded receptacle installed inside a meter socket, interfacing the terminals of the meter to the source and load conductors of the service.

**Meter Loop** - Any provision in which an electrical meter may be installed. Does not include the service disconnect device.

**Meter Pole** - A pole which supports the metering equipment owned and maintained by the customer.

**Meter Base/Socket** - The mounting device consisting of meter jaws, connectors, and enclosure for accommodating socket-type meters. The mounting device may be either a single socket or a trough to accommodate more than one mounting unit.

**Metering Equipment** - Any equipment associated with measuring electric energy.

***Municipal or State Inspector*** - The qualified representative of a city or the State of Washington Department of Labor and Industries, who has been authorized by governmental agencies to inspect electrical service installations on their behalf.

***NEC*** - National Electrical Code

***NESC*** - National Electrical Safety Code

***Neutral*** - The grounded conductor in a single-phase, three-wire or three-phase, four-wire system. The service conductor that is at zero potential to ground.

***Point of Attachment (Point of Service)*** - The point at which Puget Sound Energy's service conductors are attached to the customer's premises by an approved insulated clevis.

***Point of Delivery*** - The connection point of the meter base, on the customer's premises, where Puget Sound Energy's circuit and the customer's system are interconnected.

***RCW*** - Revised Code of Washington

***Seal*** - The locking device used to secure meter and/or service entrance equipment to assure safety and security for the unit.

***Secondary Voltage***- The lower voltage, after transformation, used to supply the customer with electrical energy. Normally less than 600 V.

***Self-Contained*** - In reference to meter sockets: a device designed and rated to continuously carry the entire capacity of the service entrance equipment through the meter.

***Service Entrance Conductors*** - Those conductors which extend between the customer's load center and point of delivery.

***Service Entrance Equipment*** - Service conduit, conductors, weatherhead, meter base, enclosures, service disconnect, and load center.

***Service Mast*** - The conduit above the meter used to provide mechanical protection for the service conductors and to support the service drop from Puget Sound Energy's system.

***Temporary Service*** - An electrical service installed by Puget Sound Energy to provide power to a customer on a temporary basis (12 months or less).

***UL*** - (Underwriters Laboratories) A nationally-recognized test laboratory which lists materials it has tested and accepted.

***UULC*** - Utilities Underground Location Center

***WAC*** - Washington Administrative Code

# Notes

---

# Notes

---