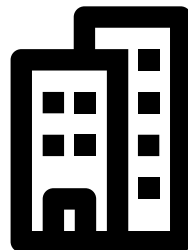


# Electric Service Handbook

March 2026

## Non-residential Projects Permanent and Temporary Service



**©2026 by Puget Sound Energy**

All rights reserved. No part of this book may be reproduced or transmitted in any form or by any means, electronic or mechanical, including photocopying, recording, or information storage and retrieval system, without permission from Puget Sound Energy (PSE).



## Our commitments to appointments and service

We stand behind our service to you. We constantly track our performance and use your feedback to make improvements. We'll credit your bill if we fail to meet our service guarantees.

- Appointment service guarantee
- 24-consecutive-hour non-major storm power outage restoration guarantee
- 120-consecutive-hour power outage restoration guarantee

Conditions apply. For more information, visit [pse.com/guarantees](https://pse.com/guarantees).

# Table of contents

## Preface

- What this handbook contains . . . . . 1
  - PSE's service availability. . . . . 1
- Electrical service equipment inspection . . . . . 1
- Codes and jurisdictions . . . . . 1
- Scheduling . . . . . 2
- Other electric service information . . . . . 2
- How to contact Puget Sound Energy . . . . . 2
- PSE's service providers . . . . . 2
- Overview: new permanent and temporary electric service hookup . . . . . 3

## Chapter 1

### Steps to a smooth permanent service installation

- The installation process . . . . . 4
- Setting up an account . . . . . 4
- Submitting an application for service . . . . . 4
- Service voltages . . . . . 5
- Know what's below: Call 811 before you dig. . . . . 5
- Cost for service . . . . . 6
- Additional service costs . . . . . 6
  - Voltage flicker and size of transformer. . . . . 6
  - Voltage drop calculations . . . . . 6

## Chapter 2

### Permanent underground services

- Service equipment installation responsibilities . . . . . 7
  - Puget Sound Energy . . . . . 7
  - Customer . . . . . 7
- Preparing for your service hookup . . . . . 7
- Cable limits for transformers . . . . . 8
- Customer-provided trenches . . . . . 9
  - Trench width for PSE facilities . . . . . 9
  - Trench routing/clearances . . . . . 9
  - Trench excavating requirements for PSE facilities . . . . . 11
  - Trench and backfill requirements for primary electric line extension trenches (no PSE gas). 11
  - Trench and backfill requirements for primary electric line extension trenches (with PSE gas). . . . . 12
- Vault excavation requirements . . . . . 12
- Conduit installed at vaults . . . . . 12

Attaching a customer's service line to a power pole . . . . .	15
When the power pole is on private property . . . . .	15
When the power pole is in a city/county/state right-of-way . . . . .	15
Racking of cable in vaults . . . . .	17
Cable ladder . . . . .	17
Cable supports . . . . .	17
Cable training and identification . . . . .	17
Customer wiring to energized PSE transformers . . . . .	19
Excavating to expose existing buried primary voltage power . . . . .	19
Single-phase minipad transformers . . . . .	19
Three-phase padmount transformers . . . . .	19
Transformer locations . . . . .	20
Landscaping and other obstacles . . . . .	23
Working space . . . . .	23
Guard posts for padmount and subsurface equipment . . . . .	24
Approved guard posts . . . . .	25
Fault current levels . . . . .	26

## Chapter 3

### Permanent overhead services

Service equipment installation responsibilities . . . . .	28
Puget Sound Energy . . . . .	28
Customer . . . . .	28
Preparing for your service hookup . . . . .	28
Service mast requirements . . . . .	29
Height requirements . . . . .	29
Clearances from gas meters . . . . .	29
Additional mast supports . . . . .	29
Screw-in service knobs . . . . .	29
Installing the service equipment . . . . .	30
List of customer-provided service entrance equipment . . . . .	30
Terrain considerations for meter base/socket locations . . . . .	30
Customer-owned meter pole . . . . .	30
Meter pole requirements . . . . .	30
Meter pole locations . . . . .	30
Guying . . . . .	31
Setting . . . . .	31
Service length . . . . .	31
Minimum pole length requirement . . . . .	31

## Chapter 4

### Meter installation

Other contacts . . . . .	33
--------------------------	----

#### Section 1: General metering requirements

Metering equipment responsibilities . . . . .	33
Puget Sound Energy . . . . .	33
Customer . . . . .	34
Other customer responsibilities . . . . .	34
Installing or removing meters by a qualified electrician . . . . .	34
Inspections and approvals . . . . .	34
Sealing provisions on enclosures . . . . .	34
Service conductors . . . . .	34
Grounding . . . . .	34
Labeling . . . . .	35
Customer equipment . . . . .	35
Current-limiting fuses . . . . .	35
Meter locations . . . . .	35
Location requirements . . . . .	35
Prohibited locations . . . . .	35
Meter location requirements for manufactured commercial structures . . . . .	36
Electrical room requirements . . . . .	36
Electrical room locations in high-rise buildings . . . . .	38
Meter bases/sockets . . . . .	38
General requirements . . . . .	38
Determining meter base/socket type . . . . .	38
Meter base/socket clearances . . . . .	39
Remote metering . . . . .	41
Meter pedestal requirements for remote metering . . . . .	42
Meter pedestal location . . . . .	42
Remote service requirements based on service ampacity . . . . .	42
Labeling . . . . .	42
Multiple meter installations . . . . .	45
Multifamily . . . . .	45
Nonresidential . . . . .	46
Multiple meter base/socket labeling . . . . .	46

#### Section 2: Self-contained metering requirements

##### Single-phase services: 400 A or less and three-phase services: 200 A or less

Meter base/socket main disconnect combinations . . . . .	47
Manual block bypass requirements . . . . .	47
Disconnecting means and its sequence . . . . .	47
Safety sockets . . . . .	47

Load balancing . . . . .	47
Service conductor connections . . . . .	47
Self-contained meter base/socket requirements . . . . .	50
Single-phase services: 400 A or less . . . . .	50
Single-phase services: 120/240 V, 200 A or less . . . . .	50
Single-phase services: 201 to 400 A . . . . .	50
Single-phase services: 120/208 V, 200 A or less . . . . .	50
Single-phase streetlight services: 120/240 V or 240/480 V pedestals . . . . .	50
Meter/panel combo units . . . . .	50
Three-phase services: 200 A or less . . . . .	51
All three-phase services . . . . .	51
Three-phase services: 120/240 V, four-wire delta . . . . .	51
Three-phase services: 277/480 V . . . . .	51
<b>Section 3: Current transformer (CT) metering requirements (up to 800 A)</b>	
<b>Single-phase services: Over 400 A and three-phase services: over 200 A</b>	
Puget Sound Energy's installation responsibilities . . . . .	53
Customer's installation responsibilities . . . . .	53
Meter base/socket . . . . .	53
Sequencing . . . . .	53
Metering circuit conduit . . . . .	53
Approval drawings required . . . . .	53
Location requirements . . . . .	53
CT enclosure . . . . .	54
Mounting the CT . . . . .	55
Customer requirements for switchboard metering (over 800 A) . . . . .	58
Approval drawings required . . . . .	58
Installing current transformers . . . . .	58
Three-phase services . . . . .	58
<b>Section 4: Primary metering requirements</b>	
<b>4.16 kV, 12.47 kV and 34.5 kV (200 A and 600 A)</b>	
Customer's responsibilities . . . . .	59
Location Requirements . . . . .	59
Data Requirements . . . . .	59
Equipment Requirements . . . . .	59

## Chapter 5

### Customer generation

Responsibilities . . . . .	62
Puget Sound Energy . . . . .	62
Customer . . . . .	62
General requirements . . . . .	63
How to apply for interconnection . . . . .	63
Interconnection system diagrams . . . . .	64
Meter location . . . . .	64
Meter socket requirements . . . . .	65
Labeling and signage requirements . . . . .	65
Disconnect switch requirements . . . . .	66
Commissioning . . . . .	67
Testing . . . . .	68
Resources . . . . .	68

## Chapter 6

### Temporary services

What this chapter contains . . . . .	69
Three-phase temporary service . . . . .	69
Definition . . . . .	69
Obtaining your temporary service from existing power facilities . . . . .	69
Scheduling . . . . .	70
Customer charge for service . . . . .	70
Temporary meter base/socket requirements . . . . .	70
Temporary underground services . . . . .	70
Meter location . . . . .	71
Trenching and excavation requirements . . . . .	71
Underground temporary service installation process . . . . .	72
Temporary overhead services . . . . .	74
Meter location . . . . .	74
Service line path requirements . . . . .	74
Clearance requirements . . . . .	74
Overhead temporary service installation process . . . . .	75

## Chapter 7

### Disconnection and modification of service

Disconnection of your meter . . . . .	77
Non-residential modified services installing new/upgrading existing with NEC required disconnect style meter (occupied structure) . . . . .	77
Modified services . . . . .	78

<b>Glossary</b> . . . . .	79
---------------------------	----

### List of tables

Table 1	Service voltages available from PSE . . . . .	5
Table 2	Color codes for locating utilities . . . . .	5
Table 3	Maximum cable runs per transformer . . . . .	8
Table 4	Clearances for padmount transformers . . . . .	20
Table 5	Maximum short circuit current (in amps) for single-phase transformers, padmounted . . . . .	26
Table 6	Maximum short circuit current (in amps) for three-phase transformers, padmounted . . . . .	26
Table 7	Maximum short circuit current (in amps) for Y-Y grounded transformers . . . . .	27
Table 8	Single-phase (nonresidential only) and all three-phase meter base/socket types . . . . .	52
Table 9	CT enclosure dimensions (minimum) . . . . .	55

## List of figures

Figure 1	Typical joint utility trench with primary voltage cable on your private property . . . . .	10
Figure 2	Minimum dimensions and excavation requirements for small, secondary connection handholes . . . . .	13
Figure 3	Minimum dimensions and excavation requirements for a single-phase padmount transformer vault . . . . .	14
Figure 4	Minimum dimensions and excavation requirements for a three-phase padmount transformer vault, 300 kVA or less . . . . .	14
Figure 5	PVC conduit riser placement when pole is on private property only . . . . .	16
Figure 6	PSE-installed underground connection handhole . . . . .	17
Figure 7	Minimum dimensions and excavation requirements for a three-phase padmount transformer vault, 500 kVA and larger. . . . .	18
Figure 8	Racking of cable in vaults . . . . .	18
Figure 9	Clearances for transformers from structures . . . . .	21
Figure 10	Clearances for transformers . . . . .	22
Figure 11	Minimum clearances from oil-filled equipment to LP, hazardous liquid, or fuel tanks . . . . .	22
Figure 12	Plan view of subsurface equipment clear working space. . . . .	23
Figure 13	Plan view of padmount equipment clear working space . . . . .	24
Figure 14	Guard post location requirements . . . . .	24
Figure 15	Typical guard posts . . . . .	25
Figure 16	Minimum clearance requirements upon installation . . . . .	29
Figure 17	Permanent overhead meter pole installation . . . . .	32
Figure 18	Typical 8 in. x 8 in. x 6 in. exterior wall-mounted AMR/AMI antenna installations . . . . .	37
Figure 19	Meter base/socket minimum clearances, without switchgear . . . . .	40
Figure 20	Switchgear installed meter and current transformer minimum clearances . . . . .	40
Figure 21	Minimum clearances for recessed meters . . . . .	41
Figure 22	320 Amp meter on customer service pole detail . . . . .	43
Figure 23	320 Amp underground remote permanent meter detail. . . . .	44
Figure 24	Typical factory-built residential multimeter panel for multifamily complex . . . . .	45
Figure 25	Typical multiple nonresidential meter installations for services 200 A or less . . . . .	46
Figure 26	Typical safety socket . . . . .	48
Figure 27	Typical arrangement of service conductors for underground commercial single-phase 320 A service . . . . .	48
Figure 28	Typical arrangement of service conductors for overhead commercial single-phase 320 A service . . . . .	49
Figure 29	Typical arrangement of service conductors for 120/208 V three-phase self-contained 200 A service. . . . .	49
Figure 30	Preferred method of conduit installation in a single-phase and three-phase CT enclosure. . . . .	54
Figure 31	Single-phase CT mounting base bracket. EUSERC 328A or 328B . . . . .	56
Figure 32	Three-phase CT mounting base bracket. EUSERC 329A or 329B. . . . .	57
Figure 33	Options for switchboard meters. . . . .	58
Figure 34	Instrument-rated CT meter bases/sockets. . . . .	58
Figure 35	Electric primary voltage Schedules 26 and 31 circuit diagrams . . . . .	60
Figure 36	Trenching requirements for power stubout . . . . .	71
Figure 37	Temporary underground service installation . . . . .	73
Figure 38	Minimum clearance requirements upon installation . . . . .	75
Figure 39	Temporary overhead service installation . . . . .	76

# Preface

This handbook is your guide to Puget Sound Energy’s (PSE) requirements for new electric service installations of less than 600 volts for commercial, industrial, multifamily, and nonresidential applications.

This handbook provides most, but not all, of the information and requirements that you will need. It does not include all possible standards and specifications required by PSE, state, federal, or local code requirements. If you need additional information, please call PSE Customer Construction Services (CCS) at **1-888-321-7779**, your local government agency, or state inspector.

---

## What this handbook contains

This handbook contains information on service installations for:

- Commercial and industrial buildings
- Apartment complexes
- Community wells
- Condominium complexes
- Barns and shops

If the type of service you need is not addressed in this handbook, please contact PSE’s CCS at **1-888-321-7779**.

### PSE’s service availability

General boundaries for PSE’s gas and electric service areas are available on [pse.com/construction-services](https://www.pse.com/construction-services). A CCS Representative can help you to determine the closest available service line and can provide you with cost information for establishing new service.

---

## Electrical service equipment inspection

Once your service equipment is installed, the state of Washington or the city with jurisdiction over your area requires that your installation pass an electrical inspection before PSE can connect you to the system. It is your responsibility to request this inspection.

---

## Codes and jurisdictions

This handbook shall not be interpreted to conflict with the regulations of the state of Washington or other regulatory bodies having jurisdiction. PSE’s metering requirements may be more stringent. Local codes and requirements related to the planned work should be addressed before any construction begins.

---

## Scheduling

Engineering, scheduling, and construction of the work will vary depending upon the complexity of the job and the volume of work requested by PSE customers. Contact your CCS Representative at **1-888-321-7779** for current construction scheduling.

---

## Other electric service information

Puget Sound Energy's guides and handbooks are available at the [Construction Services Guides and Handbooks web page](#).

---

## How to contact Puget Sound Energy

You can obtain further information by contacting us through the following:

- Go to [pse.com/construction-services](https://pse.com/construction-services)
- Or call PSE Customer Construction Services (CCS) at **1-888-321-7779**  
Monday through Friday, 7 a.m. – 5 p.m.

If you have questions about Energy Efficiency Programs:

- Go to [pse.com/rebates](https://pse.com/rebates)
- Or call PSE Energy Advisors at **1-800-562-1482**  
Monday through Friday, 8 a.m. – 5 p.m.

If you have general questions regarding your account, such as changing service or questions about your bill:

- Go to [pse.com/customer-service/help-center/my-account](https://pse.com/customer-service/help-center/my-account)
- Or call Customer Service at **1-888-225-5773**; TTY **1-800-962-9498**  
Monday through Friday, 7:30 a.m. - 6:30 p.m.

If you have an emergency or a service delivery issue, please call:

- Customer Service at **1-888-225-5773**; TTY **1-800-962-9498**  
24 hours a day, 7 days a week.

---

## PSE's service providers

PSE contracts with two partner companies to provide construction services: Potelco, Inc. and InfraSource Construction LLC. The employees who install your service may work for these service providers on PSE's behalf.

## Overview: new permanent and temporary electric service hookup

---

This information applies only if PSE has existing power facilities in your area.

If electric power is not readily available, please contact: Customer Construction Services **1-888-321-7779** or [pse.com/construction-services](https://www.pse.com/construction-services).

### Commercial/ industrial and multifamily projects customer responsibilities

- Determine if you need overhead or underground service.
- Contact PSE to establish an account, and order your service.
- Obtain an electrical work permit.
- Determine the service rating you want (for example, 200 A or 400 A).
- Determine an approved meter location.
- Notify other utilities of your project.
- Ensure that existing underground utilities are located before you dig. Call 811 at least two business days before you dig.
- Prepare job site by providing a clear path/trench for your service line for proper vault entrance requirements per PSE standards.
- Obtain an approved electrical inspection.
- After the electrical inspection has been completed and approved, request that PSE install and energize your system.

### PSE's responsibilities

- Determine if engineering is required.
- Install your overhead or underground permanent service line conductors.
- Install your meter and energize your system.

### Scheduling/ time frame

- If engineering is not required, services are typically installed and energized 3 to 5 days after you have passed your inspection. Engineering, right-of-way permits, etc., **can extend time by 8 weeks or more.**

### Service charge

- Charges vary due to the type of service you request and the type of system we have in your area. Contact your CCS Representative for current rate information.

# Chapter 1

## Steps to a smooth permanent service installation

---

### The installation process

Before a permanent service is energized, you are required to complete the following:

- Establish an account with PSE by calling Customer Construction Services (CCS) at **1-888-321-7779**.
- Determine the type of service needed and if that service will be underground or overhead.
- Install required service equipment and underground service cable (if applicable).
- Obtain an electrical inspection.
- Call PSE and request that your service be energized.

---

### Setting up an account

Before PSE can provide new service, you must establish an account. Simply call CCS at **1-888-321-7779**. They will request billing information and the address for the new service from you. If you wish, we can initiate your temporary service order at the same time.

---

### Submitting an application for service

Call Customer Construction Services (CCS) at **1-888-321-7779** and submit Electric Service Application Permanent Non-Residential 201E or Electric Service Multi-Family Development 400E. All forms can be downloaded at [pse.com/construction-services](https://pse.com/construction-services).

When you fill out the application, make sure that it is as complete as possible, and include a copy of each of the following items (if applicable) with the application:

- Legal description of the property
- Title insurance policy, recorded warranty deed, or real estate contract
- Site plan
- Landscaping plan
- Water main plan
- Sewer main and profile plans
- Road and storm drainage plan
- Road cross-section plan
- Streetlight requirements

**NOTE:** Several of the above plans may be included in one CAD and Civil drawing.

## Service voltages

We offer the following standard voltages for nonresidential customers:

Table 1

Service voltages available from PSE

Service type	Voltage
Single-phase	120/208 V, 3-wire *
	120/240 V, 3-wire **
Three-phase	120/208 V, 4-wire
	277/480 V, 4-wire

\* Available only if 120/208 secondary voltage exists at the location at the time you apply for service.

\*\* Available for loads up to a maximum demand of 100 kW.

## Know what's below: Call 811 before you dig



Before excavating, Washington law requires you to call 811 to locate underground utility lines. Doing so will enable you to avoid potential injury, fines, costly repair of PSE utility facilities, and electric or natural gas service disruptions. Call 811 a minimum of two full business days prior to digging. (For example, call Wednesday to dig on Monday.) When you call, an operator will record information about your dig and notify affected utility companies, including PSE. PSE locates and marks its own lines for free, but privately owned utility lines must be located by a separate vendor, typically for a fee.

The locate service uses the following color codes to identify underground utilities:

Table 2

Color codes for locating utilities

Color	Utility
White	Proposed excavation area
Pink	Temporary survey markings
Red	Electric power lines, cables, conduit, and lighting cables
Yellow	Natural gas, oil, steam, petroleum, or gaseous materials
Orange	Communication, alarm or signal lines, cables, or conduit
Blue	Potable water
Purple	Reclaimed water, irrigation, and slurry lines
Green	Sewers and drain lines

**NOTE:** Use white paint to mark the area within which you want utility locations.

Once all utilities are located:

- Do not dig with machinery within 3 feet of the locate marks.
- Hand dig to expose all utilities to be crossed.

---

## Cost for service

Contact your CCS Representative or PSE Project Manager to determine the cost for service.

---

## Additional service costs

### Voltage flicker and size of transformer

Commercial/industrial customers—If the system will serve a facility that is purposely built to serve a single specific customer, and that customer will operate the facility and is knowledgeable about flicker, then the system shall be designed to deliver no more than 3 percent voltage flicker at the point of service.

Multifamily customers—If a transformer is built to serve multiple customers, a maximum of 3 percent or less is specified at the point of service. This is common to all customers.

In your Application for Service, you must provide PSE with the locked rotor starting currents for the largest single-phase and three-phase motors. After we determine the size of transformer required to serve the new load of the facility, we will calculate the percent voltage flicker (from the motor's starting current) at the point of service and provide that number to you.

If this voltage dip exceeds PSE's limits based on facility type, the transformer size must be increased to compensate for this. **You will be responsible for the difference in cost of the larger transformer**, or you will need to install sufficient controls to bring flicker back within PSE's limits.

**NOTE:** We will size PSE's facilities to provide a level of voltage flicker that is normally acceptable to customers. If you need to be served with a higher quality of service, contact your CCS Representative or PSE Project Manager.

### Voltage drop calculations

You are responsible for calculating the overall voltage drop to your facility and determining what is an acceptable level for your facility. If you determine that the voltage drop is unacceptable, you must determine a solution. Some possible solutions are:

- Run separate services from PSE's transformer for motor loads.
- Modify or upgrade your equipment or underground service cables (if applicable).
- Pay PSE to increase the size of our transformer.
- Pay PSE to provide a second transformer.

# Chapter 2

## Permanent underground services

---

This chapter provides you with information on PSE's underground service installation. Please follow these requirements to avoid a delay in your service hookup. If you have any questions about this information, call Customer Construction Services (CCS) at **1-888-321-7779**.

---

### Service equipment installation responsibilities

<b>Puget Sound Energy</b>	PSE is responsible for furnishing, installing, and maintaining the primary voltage system equipment. This equipment includes primary conduit and cables, service conductor connectors at the transformer, current transformers (CT), meter(s), and meter wiring.
<b>Customer</b>	<p>You are responsible for furnishing, installing, and maintaining all required service entrance equipment, including the service entrance conduits* from the meter socket or current transformer enclosure to PSE's designated point of delivery.</p> <p>For services where current transformers are required, you will also need to run gray electrical conduit from the CT enclosure to the meter base. Refer to Chapter 4, Section 3, Current Transformer (CT) Metering (up to 800 amps) for more information.</p> <p><b>NOTE:</b> PSE will supply, install, and maintain the CTs and meter wiring.</p> <p>* DO NOT run a grounding wire to PSE's point of connection at the transformer or handhole. PSE will not connect it.</p>

---

### Preparing for your service hookup

The following list will help you prepare your project for the installation of an underground service. After you complete these items, PSE will connect your service and install the metering equipment.

1. Check for any local ordinances/covenants that may prevent you from obtaining an underground service.
2. Complete Electric Service Application Permanent Non-Residential 201E or Electric Service Multi-Family Development 400E.
3. Supply site drawings and load information to your CCS Representative (refer to the submitting an application for service section in Chapter 1, Steps to a Smooth Permanent Service Installation).
4. Contact CCS to determine where your underground service will originate.
5. Determine an approved meter location (refer to the meter locations section in Chapter 4, General Metering Requirements).
6. If required by CCS, provide an easement for any permanently installed PSE equipment located on your property.

7. Provide payment for any preconstruction costs determined by your CCS Representative.
8. Provide all excavation for PSE's facilities and get an approval for the proper vault entrance location of your conductor/conduit.
9. Provide service conductors.
10. Install required service entrance equipment.
11. Connect the meter sockets and permanently label them to indicate the part of the premises they serve, such as unit number.
12. Obtain an approved electrical inspection.
13. Call CCS at **1-888-321-7779** to initiate a connection and energize your new service.

### Cable limits for transformers

The maximum number of secondary conductors allowed for a specific transformer size is limited to those listed below in Table 3.

**Table 3** Maximum cable runs per transformer

Transformer Size and Voltage (PSE-provided)	Maximum secondary cable connections (Customer-provided) *
45 through 300 kVA, 120/208 V secondary	12 Runs #2 – 500 mcm OR 10 Runs 501 – 750 mcm
45 through 300 kVA, 277/480 V secondary	12 Runs #2 - 500 mcm OR 10 Runs 501 - 750 mcm
500 through 750 kVA, 120/208 V secondary	18 Runs #2 – 500 mcm OR 14 Runs 501 – 750 mcm
500 through 750 kVA, 277/480 V secondary	12 Runs #2 - 500 mcm OR 10 Runs 501 - 750 mcm
1000 kVA, 120/208 V secondary	24 Runs #2 – 500 mcm OR 18 Runs 501 – 750 mcm
1000 kVA, 277/480 V secondary	18 Runs #2 - 500 mcm OR 14 Runs 501 - 750 mcm
1500 through 2500 kVA, 277/480 V secondary	24 Runs #2 - 500 mcm OR 18 Runs 501 - 750 mcm

\* These are maximum allowed per the transformer size and voltage, however, the sizing of the vault and training of the cable might reduce these runs. The availability of open position shall be verified. Contact your CCS representative or project manager for your specific requirements.

---

## Customer-provided trenches

### Trench width for PSE facilities

The minimum trench width is 18 inches; however, the excavator may need to increase the trench width depending on the other conduits/lines being installed in the trench.

When increasing the trench width, remember to allow a minimum of 12 inches of horizontal separation between PSE's electrical conduits/cables and gas lines.

PSE will allow **customer-owned facilities** within an electric power trench, if the following minimum horizontal clearances from PSE facilities are maintained:

- 18 inches minimum for customer-owned tight-line sewer (not tile), natural gas lines, propane gas lines, fuel oil lines, and water mains up to 6 inches in diameter.
- 12 inches minimum for water service, irrigation pipes, lighting, security and electric supply circuits, communications lines, culverts, and closed system roof drains/storm drains (not French drains).

**NOTE:** When constrained by obstructions or clearances from other buried utility lines/facilities, the horizontal clearance between PSE power and communications may be reduced to 4 inches with mutual agreement from the participating communications providers. It is your responsibility to obtain agreement from participating communications providers for a reduced clearance when needed.

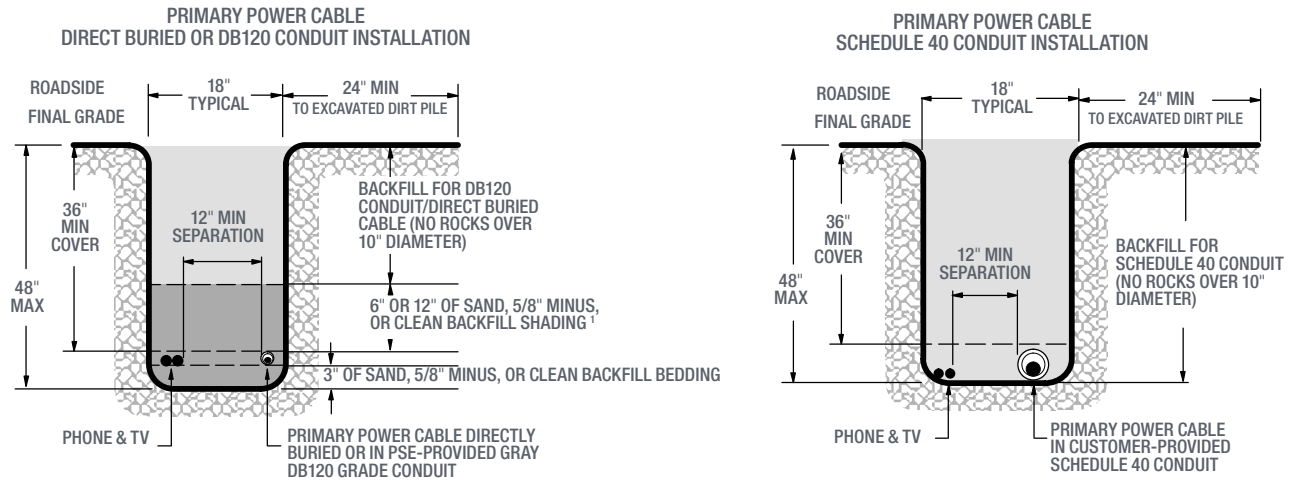
Figure 1 illustrates PSE's width and depth requirements for primary cable voltage line extension trenches on private property with and without a gas line present.

For trenching requirements with a gas line present, refer to the Joint Utility Mainline Trench Excavation Requirements.

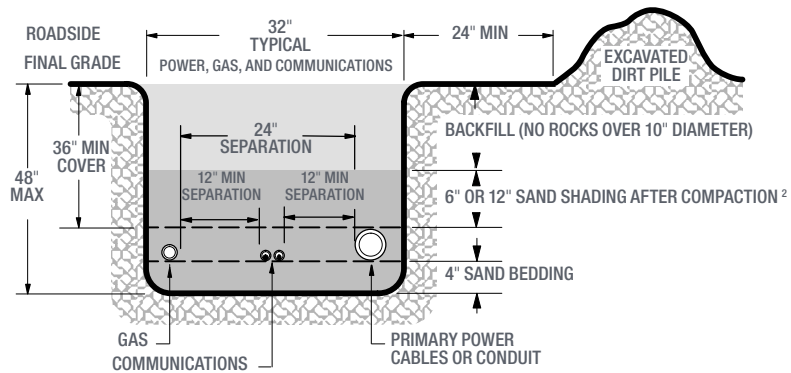
### Trench routing/clearances

The routing of a customer-provided trench must maintain a minimum of 5 feet from septic tanks and a minimum of 10 feet from drain fields.

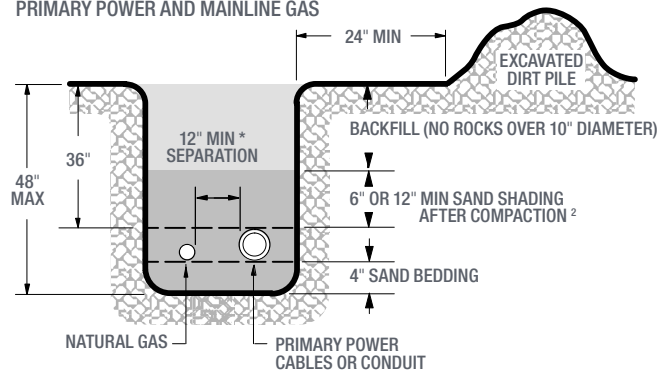
**Figure 1** Typical joint utility trench with primary voltage cable on your private property (cross-section view)



**PRIMARY POWER, MAINLINE GAS, AND COMMUNICATIONS**



**PRIMARY POWER AND MAINLINE GAS**



**NOTE 1**  
SEE TRENCH AND BACKFILL REQUIREMENTS FOR PRIMARY ELECTRIC LINE EXTENSION TRENCHES (NO PSE GAS) IN THIS CHAPTER.

**NOTE 2**  
SEE TRENCH AND BACKFILL REQUIREMENTS FOR PRIMARY ELECTRIC LINE EXTENSION TRENCHES (WITH PSE GAS) IN THIS CHAPTER.

\* THE MINIMUM DISTANCE BETWEEN THE SURFACES OF TWO UTILITIES, NOT THE CENTERLINE DISTANCE.

### Trench excavating requirements for PSE facilities

The following requirements for the trench must be met before power conduits/cables will be installed.

- When you trench in the right-of-way on PSE's behalf, the governing jurisdictions issue public roadway use permits to PSE. PSE requires that you provide a signed Excavation Requirements & Final Grade Certification document that is supplied by your PSE Project Manager.
- For trench work provided by you within a public right-of-way or a PSE easement, PSE requires that you use a Washington State licensed and bonded contractor and complete and sign a PSE trenching agreement form.

**NOTE:** Acquiring permits for excavation-related activity can take up to a month or longer depending on the amount of material being excavated, the location of the excavation, and the jurisdiction issuing the permit. To avoid schedule delays, contact your PSE Project Manager for an estimated time frame for acquiring your permits.

- The trench shall be excavated according to the trench detail, and PSE's work sketch.
- The trench shall be straight and the trench bottom shall be smooth, level, and free from debris, garbage, sharp objects, or rocks larger than 4 inches.
- If PSE cable will be direct buried or in gray DB120 conduit, you must provide at least 3 inches of sand bedding on the bottom of the trench.
- Excavated or loose material shall be placed at least 2 feet from the field edge of the trench.
- Water shall be removed by pumping or draining.

**Restrictions:** When PSE's project scope requires the manipulation of an existing primary cable or circuit, customers or third-party contractors shall not uncover and expose existing buried primary voltage power lines or ducts in an energized state. PSE shall coordinate with the customer and service provider for the lines to be de-energized and grounded, or PSE shall provide qualified workers to perform exposure of energized buried lines. These restrictions apply to both direct-buried cables and cables in conduit.

### Trench and backfill requirements for primary electric line extension trenches (no PSE gas)

PSE will not energize its facilities until the backfill is complete.

When PSE primary cables are directly buried, or installed in gray DB120 grade conduit, you are responsible for the following:

- Providing a minimum 3-inch bedding layer of sand, 5/8-inch minus, or clean backfill (with rocks or solid material no larger than 5/8 inch in diameter and no sharp objects) placed below cables/conduits.
- A 12-inch shading layer of the same material above the directly buried cables or DB120 conduit.
- If native backfill is completely free of foreign objects and rocks in excess of 8 inches in diameter, shading with sand, 5/8-inch minus, or clean backfill can be reduced to 6 inches.
- The remaining trench shall be backfilled with soil that is free of rocks larger than 10 inches in diameter and foreign objects.

When PSE primary cables are installed in gray Schedule 40 grade conduit, you are responsible for the following:

- Backfilling the trench with soil that is free of foreign objects and rocks larger than 10 inches in diameter. Bedding and shading of the conduit with sand, clean backfill or select fill as 5/8-inch minus crushed aggregate is not required.

### Trench and backfill requirements for primary electric line extension trenches (with PSE gas)

You must provide a 12-inch layer of sand above and a 4-inch layer of sand bedding below the utilities before backfilling (see Figure 1). If native backfill is completely free of foreign objects and rocks in excess of 8 inches in diameter, sand shading over utilities can be reduced to 6 inches after compaction.

You are responsible for the following:

- Completing backfill as soon as practical after facilities are placed and inspected.
- Carefully placing backfill to prevent damage or movement of the cables or conduit.
- Cost of damages to PSE facilities caused by improper backfill or compaction.
- Relocation costs due to change in grade or alignment.

**CAUTION:** Do not use a compactor directly over the power conduit(s) until at least 30 inches of backfill is in place so that the compactor will not damage the cables or conduit. Do not penetrate the soil deeper than 3 inches during compaction with a backhoe compactor.

---

### Vault excavation requirements

You are responsible for the following:

- Excavating the vault or handhole location. The most commonly used vault types and the required excavation dimensions are shown in Figures 2–4.
- Removing debris and leveling the bottom of the excavation with a 6-inch base of crushed rock.
- Backfilling the excavation to finished grade at 2 inches below the vault top (if in a landscaped area), or backfilling flush with the grade (if in a hard-surfaced area).
- Installing a felt joint around the vault top or cover when concrete is poured up to the vault (e.g., when the vault is to be in a sidewalk).

---

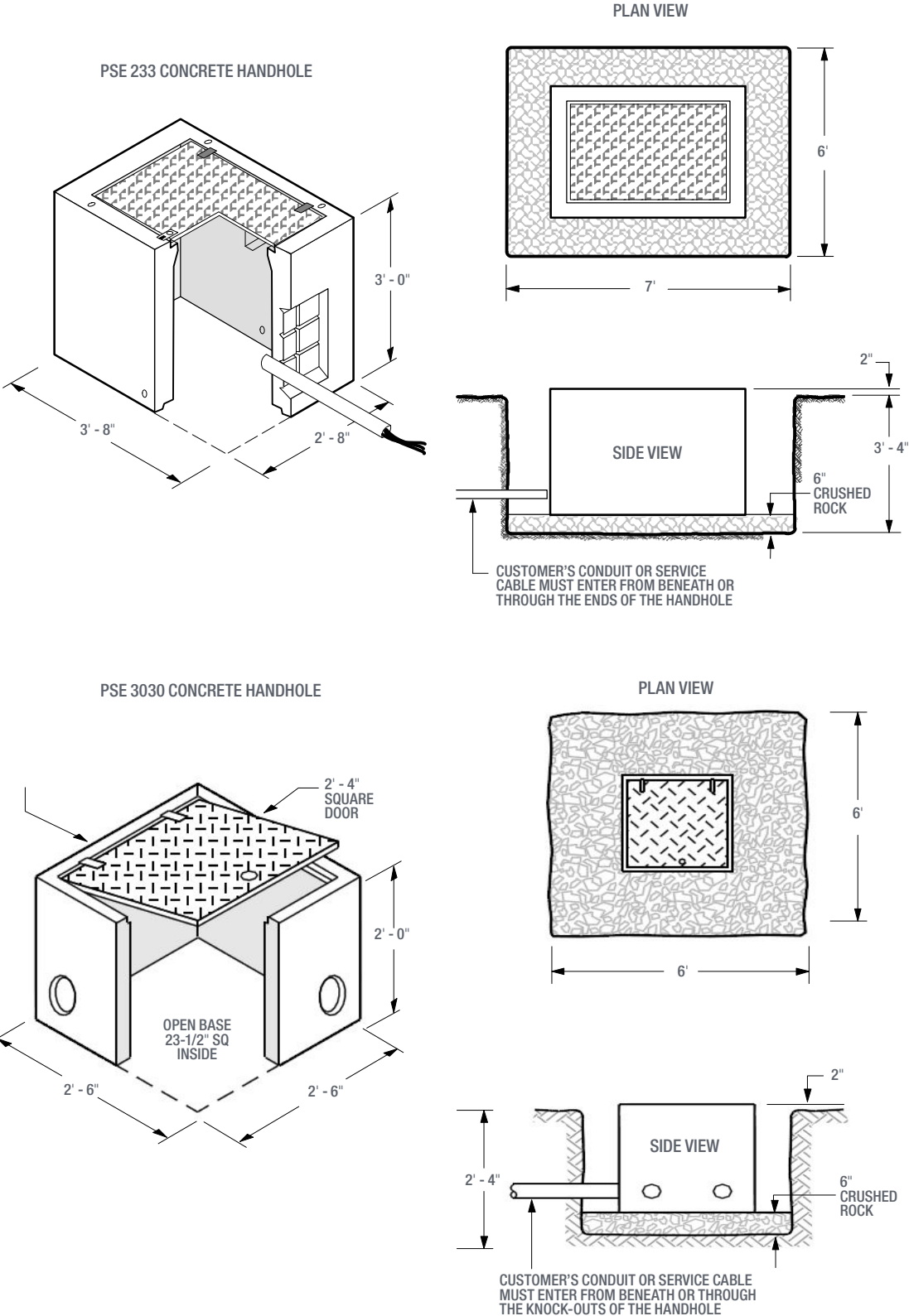
### Conduit installed at vaults

You are responsible for the following:

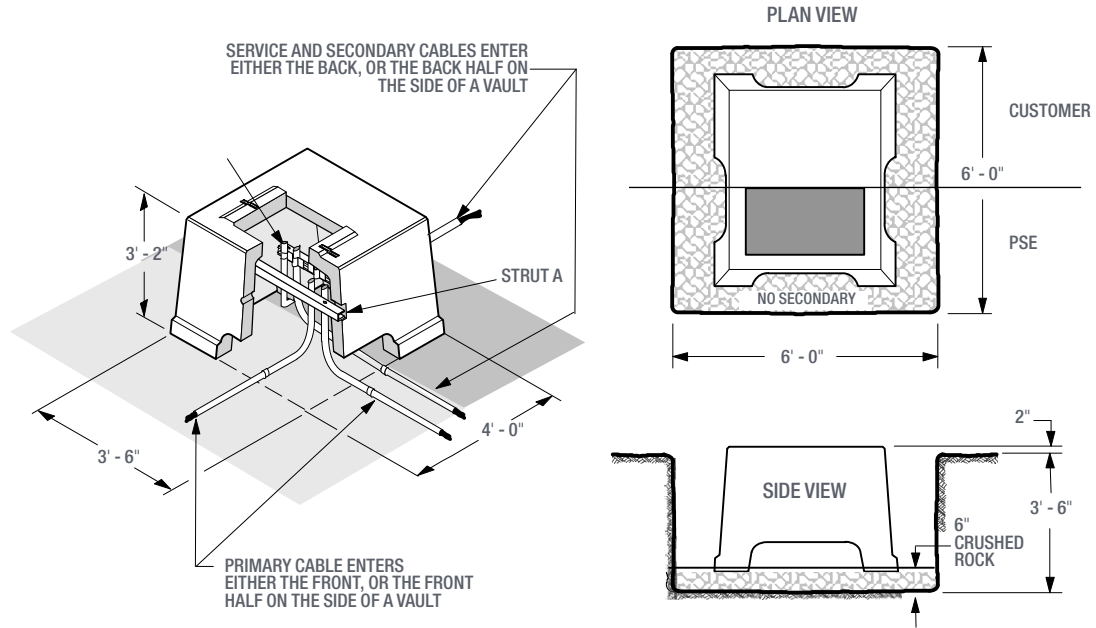
- Contacting PSE (Customer Construction Services or a Project Manager if one has been assigned) for entry location approval and procedures **prior** to excavating and extending conduit for your new service.
  - » This is critical as it may not enter the same quadrant as PSE's primary cable.
  - » Customer wire must enter and wrap in the same direction as PSE cable(s).
  - » Conduit must not enter a vault at an angle as it will make training the cable along the vault walls difficult.
- Grouting around your service conduit(s) that enter a PSE vault (except for the vault types shown in Figure 3).
- Sealing service entry conduit at PSE's vault to prevent water from entering into your service panel.

**NOTE:** Refer to the Customer wiring to energized PSE transformers section of this chapter for information about the installation of commercial service underground cable.

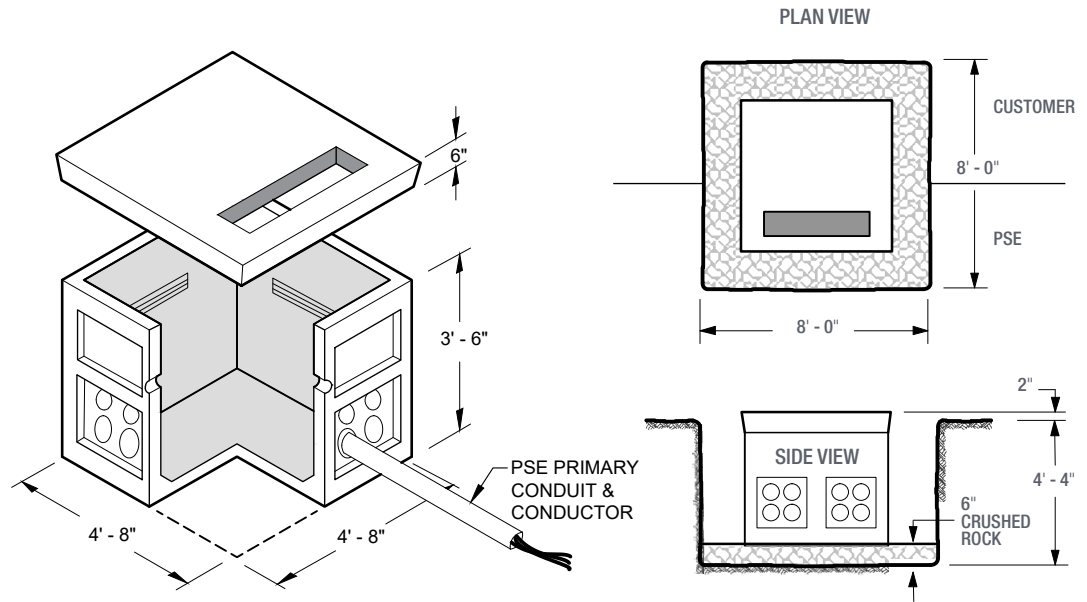
**Figure 2** Minimum dimensions and excavation requirements for small, secondary connection handholes



**Figure 3** Minimum dimensions and excavation requirements for a single-phase padmount transformer vault



**Figure 4** Minimum dimensions and excavation requirements for a three-phase padmount transformer vault, 300 kVA or less



---

## Attaching a customer's service line to a power pole

### When the power pole is on private property

As a commercial customer, you may attach, own, and maintain up to two service conduit risers on a PSE power pole (see Figure 5), when the pole is located on private property. Three or more conduit service risers require an underground connection handhole (see Figure 6).

If no other risers exist on the pole, attach the first 10 feet of the conduit riser(s) in location 3 (see the plan view of Figure 5). For the location of other riser(s), contact your CCS Representative or your Project Manager for approval prior to installation.

**NOTE:** All installation work performed on the pole above 10 feet from grade shall be done by electric utility crews.

### When the power pole is in a city/county/state right-of-way

When PSE's power pole is within a governmental right-of-way, PSE will install a secondary handhole on your property to provide a point of service (see Figure 6). Call CCS for coordination and guidance before attaching service conduits to PSE power poles within a governmental right-of-way.

**Figure 5** PVC conduit riser placement when pole is on private property only

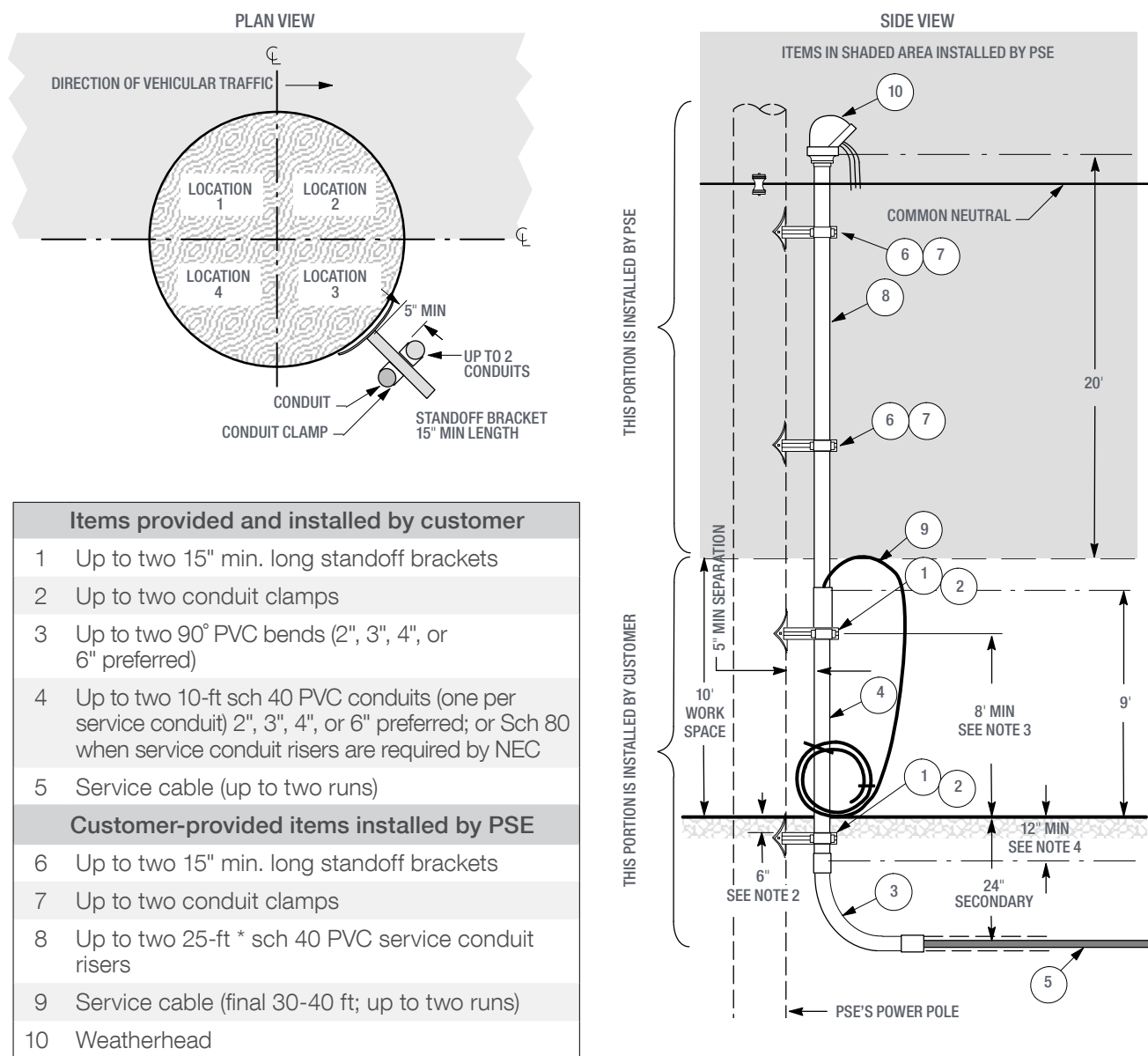
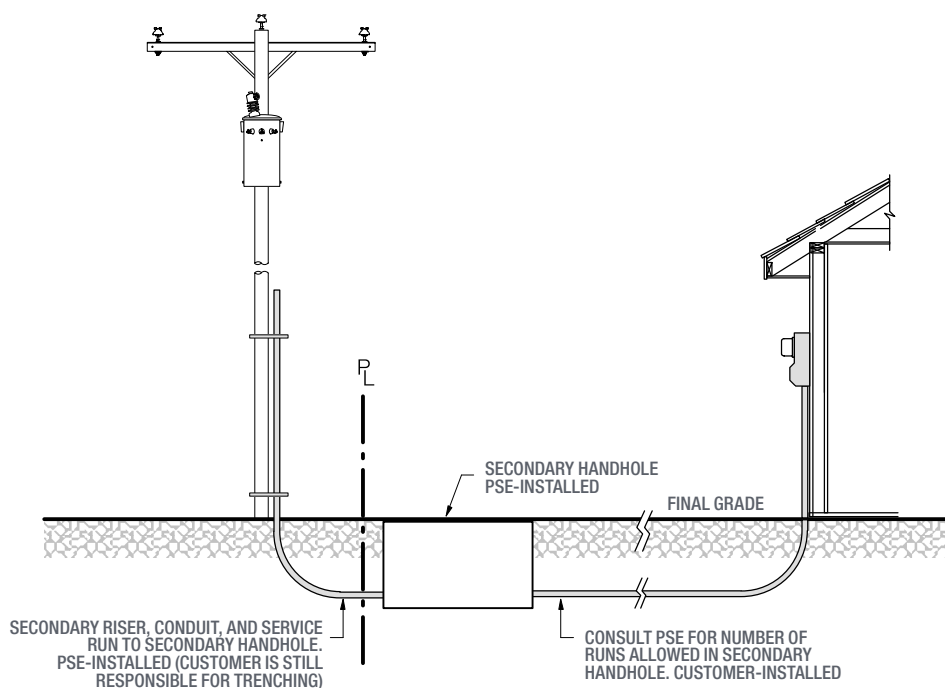


Figure 6 PSE-installed underground connection handhole



## Racking of cable in vaults

The following applies to 7- x 7- x 6-foot vaults for three-phase padmount transformers of 500 kVA and greater, where 12 or more runs of 500 kcmil or larger cables are installed.

### Cable ladder

In all 7- x 7- x 6-foot vaults, PSE would install or provide a 30-inch x 4-foot ladder with 6-inch spacing between rungs. The cable ladder will be positioned approximately 19 inches from the left side of the vault wall under the cable access hole.

### Cable supports

Cable support racks and arms, that hold cables along the perimeter of the vault wall, are recommended but not required by PSE.

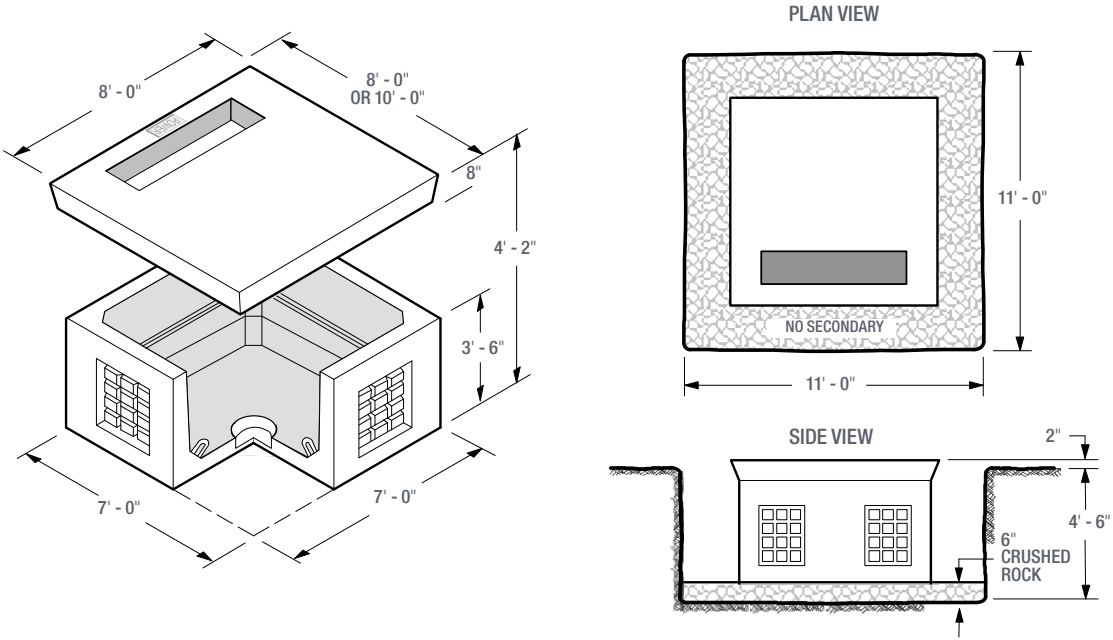
If cable supports are installed, they shall extend a maximum of 2 feet from the vault wall. The customer may install as many cable supports as they consider necessary.

### Cable training and identification

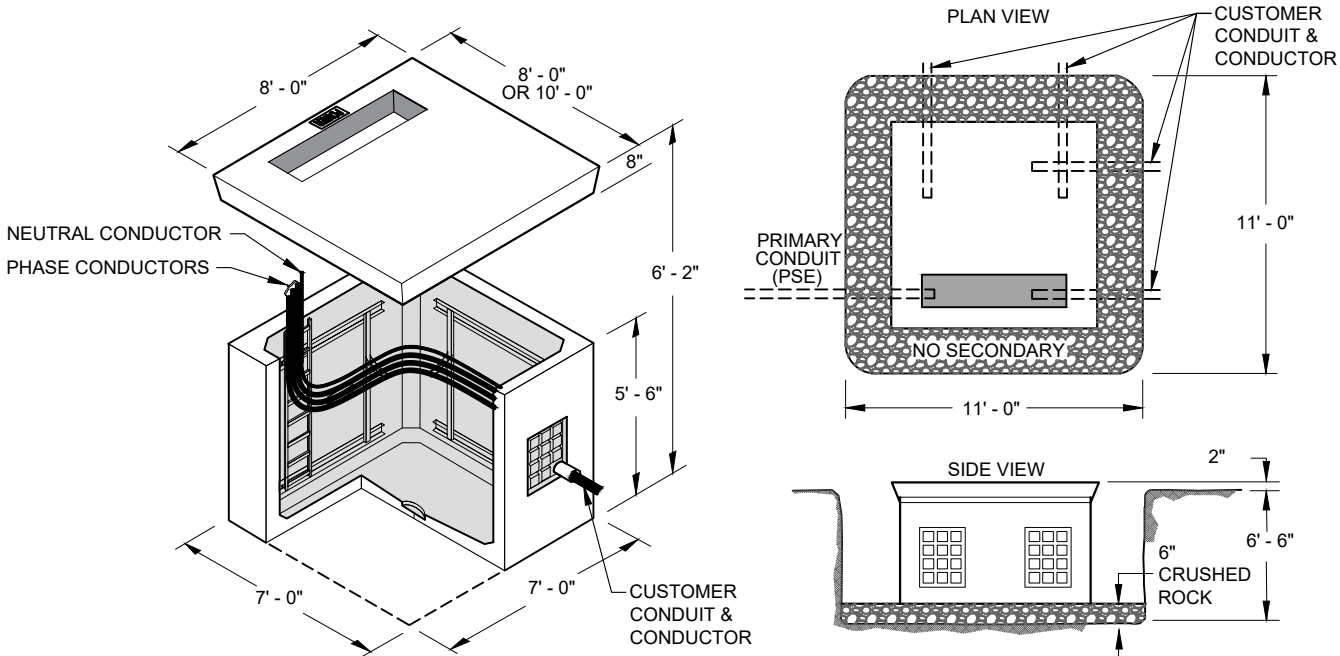
The requirements for cable training and identification are shown below.

- The cable shall extend a minimum of 7 feet above the transformer pad.
- All cables shall be bundled together by phase.
- Cables shall be zip tied to the cable ladder rungs.
- The neutral conductor shall be positioned on the cable ladder (see Figure 8).
- The cable shall be marked with colored tape to indicate its phase. Color extruded, jacketed conductors are also acceptable for identification.

**Figure 7** Minimum dimensions and excavation requirements for a three-phase padmount transformer vault, 500 kVA and larger



**Figure 8** Racking of cable in vaults



---

## Customer wiring to energized PSE transformers

### Excavating to expose existing buried primary voltage power

Before installing commercial service underground cable into any energized transformer, coordinate the work with PSE to ensure a safe installation.

### Single-phase minipad transformers

Your electrician may insert conduit 2 inches into an energized minipad transformer. Routinely, PSE must uncover existing buried primary power cables in order to maintain, intercept and reroute, or cut new equipment into the circuit such as transformers or J-boxes. In these situations, the excavation taking place must be coordinated with the customer with respect to the hazards a buried energized line presents.

Customers preparing a trench up to a cable intercept point shall not uncover the cable ahead of the scheduled date for line work. Customers preparing a trench route to a cable intercept point must stop 3 feet from locate marks prior to the start of PSE line construction work.

The cable shall be isolated, tested, and grounded, by qualified electrical workers, rendering the cable de-energized. Only then may a customer proceed to expose PSE's cable through normal safe work and digging practices.

For single-phase padmount transformer vaults with unistrut construction, you may, at your discretion, provide a minimum 24-inch radius PVC bend for PSE to attach to the unistrut.

Work that involves inserting or pulling cable into the minipad handhole shall be done only:

- After the transformer has been de-energized.
- With the on-site assistance of a PSE journeyman.

To train the cable and mark the runs:

- Mark the cables and group them together.
- Label the conductors with the location and service address.
- Leave no more than 8 feet of cable coiled in the vault, neatly installed and taped together.

### Three-phase padmount transformers

The customer's electrician may install and grout conduit into a vault wall or insert/pull cable into three-phase transformer vaults only:

- After the transformer has been de-energized.
- With the on-site assistance of a PSE journeyman.

To train the cable and mark the runs:

- Label each cable's phase and the neutrals.
- Depending on the entry wall and vault size, leave 20-30 feet of cable coiled in the vault. Contact your project manager for the exact cable footage.

## Transformer locations

PSE will install padmount transformers using the clearances listed in Table 4 and shown in Figures 9 and 10.

Clearances between padmount transformers, including subsurface ones in vaults, and structures must be measured from the metal portion of the transformer closest to the building or structure, including any building overhangs, within the following clearances:

**Table 4** Clearances for padmount transformers

Feature	Clearance distance
Combustible walls or roof (including stucco).	10 feet. See Figure 9.
Noncombustible walls (including brick, concrete, steel, and stone), provided the side of the transformer facing the wall does not have doors. Materials that pass UBC Standard 2-1 or ASTM E136-79 are considered to be noncombustible.	3 feet. See Figure 9.
Fire sprinkler valves, standpipes, and fire hydrants.	6 feet. See Figure 10
Doors, windows, vents, fire escapes, and other building openings.	10 feet. See Figure 10.
The water's edge of a swimming pool or any body of water.	15 feet. See Figure 10.
Individual domestic and irrigation wells.	100 feet. See Figure 10.
Facilities used to dispense or store LP or hazardous liquids or fuels.	20 feet. See Figure 11. 10 feet. See Figure 11.
Gas service meter relief vents.	3 feet. See Figure 10.
Generators, customer-owned transformers, etc.	6 feet.

Figure 9 Clearances for transformers from structures

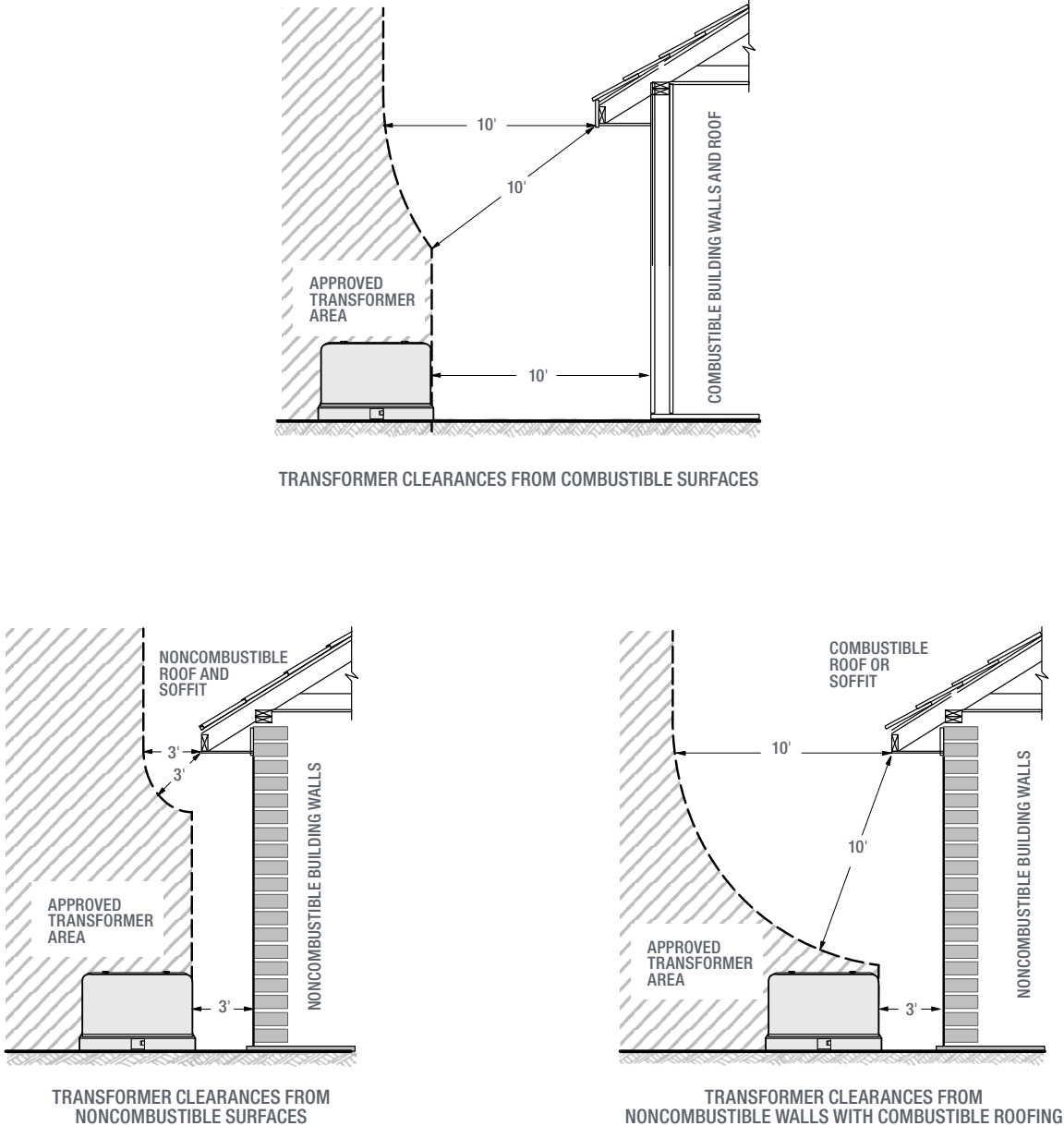


Figure 10 Clearances for transformers

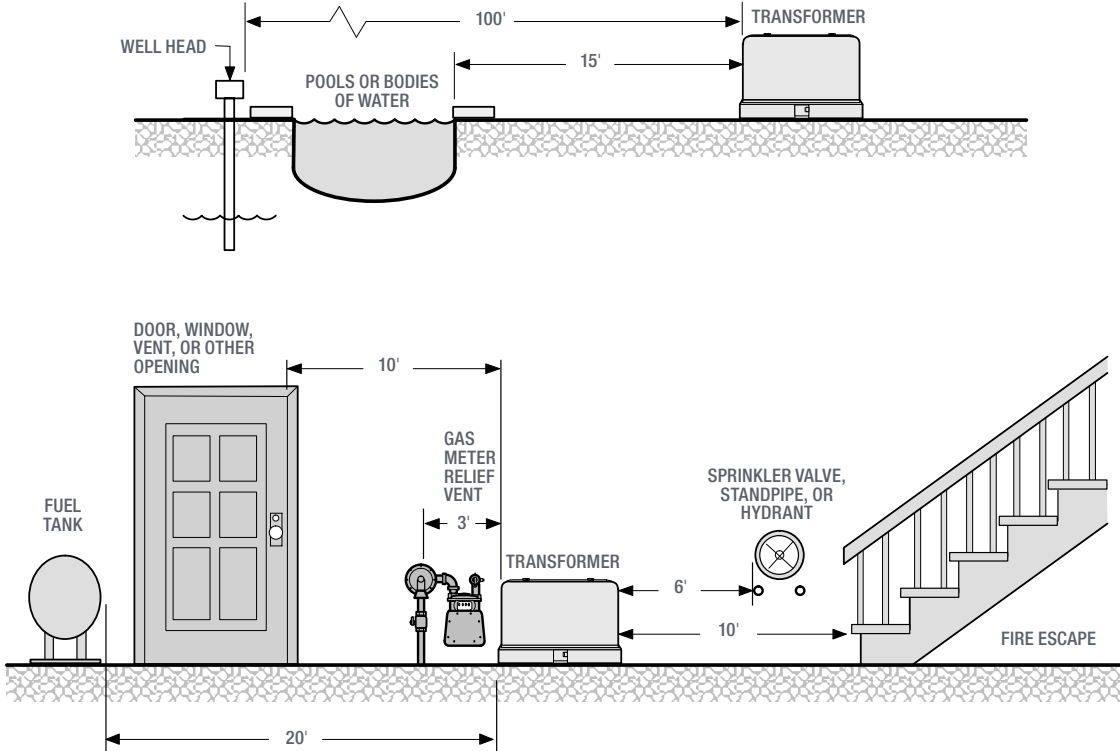
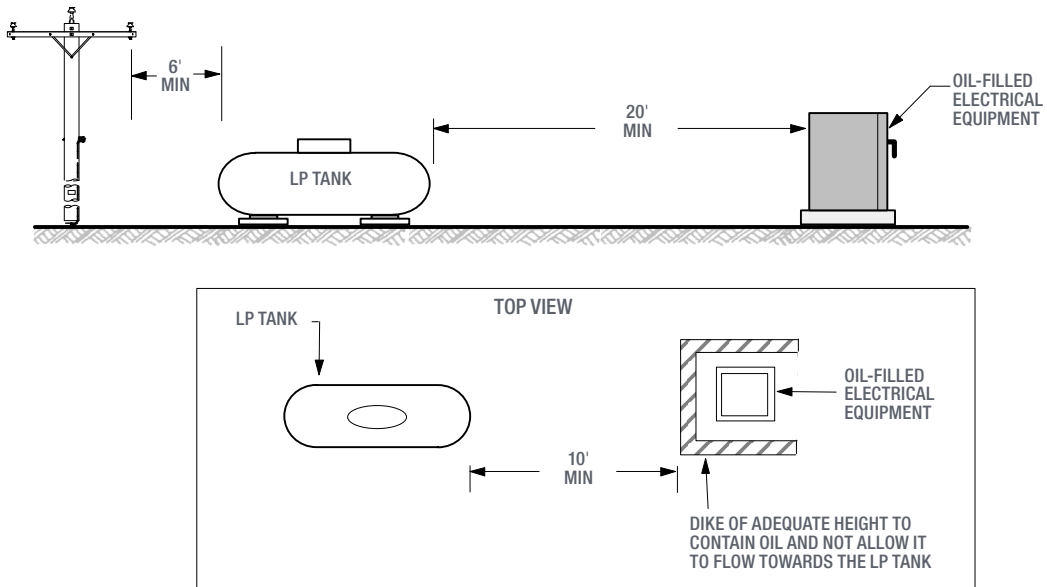


Figure 11 Minimum clearances from oil-filled equipment to LP, hazardous liquid, or fuel tanks



---

## Landscaping and other obstacles

Landscaping and other obstructions shall not encroach on the clearances shown in Figures 12 and 13.

---

## Working space

A clear and level working area equal to the full width of the equipment operating compartments shall extend a minimum of 10 feet from the compartment opening for padmount equipment and 10 feet in front of subsurface equipment in vaults (see Figures 12 and 13).

A minimum of 3 feet of clear working area for subsurface equipment and 18 inches for padmount equipment (see Figures 12 and 13) shall be provided on the sides of the electrical equipment without operating compartments (including sides with cooling fins).

A clearance of 36 inches is required on padmounted equipment with cooling fins (see Figure 13).

**Figure 12** Plan view of subsurface equipment clear working space

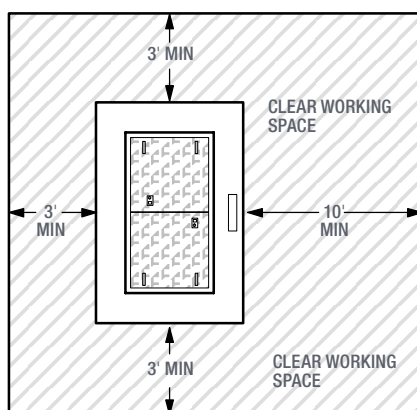
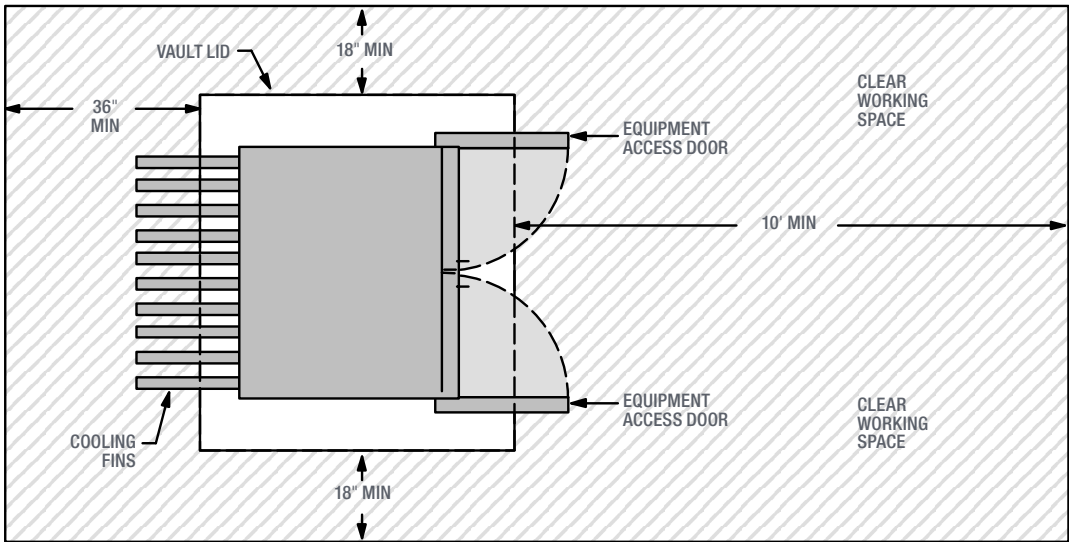


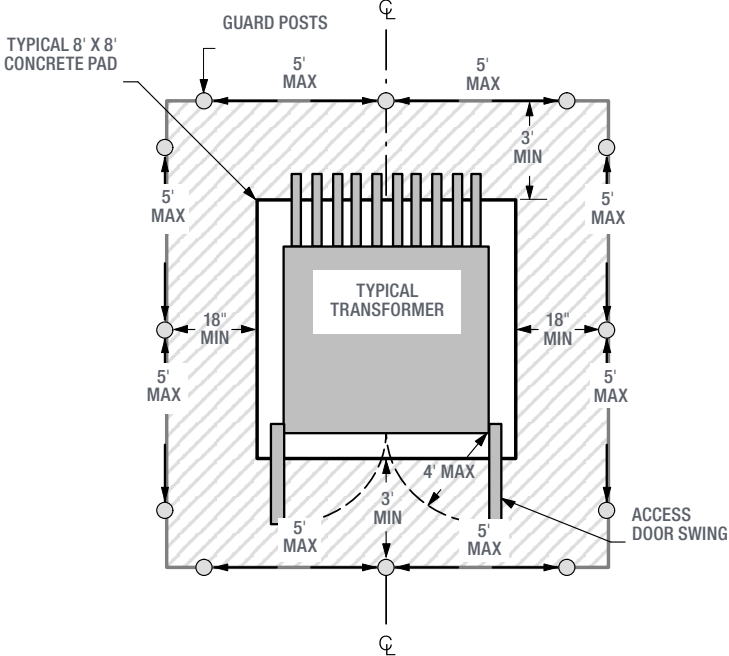
Figure 13 Plan view of padmount equipment clear working space



**Guard posts for padmount and subsurface equipment**

Washington Administrative Code (WAC) requires guard posts around padmounted equipment that is exposed to vehicular traffic. PSE guard post location requirements are shown in Figure 14. You are required to supply and install these guard posts or pay PSE to supply and install them.

Figure 14 Guard post location requirements



**NOTE:** Installation of guard posts must be completed before the primary cable is installed and energized.

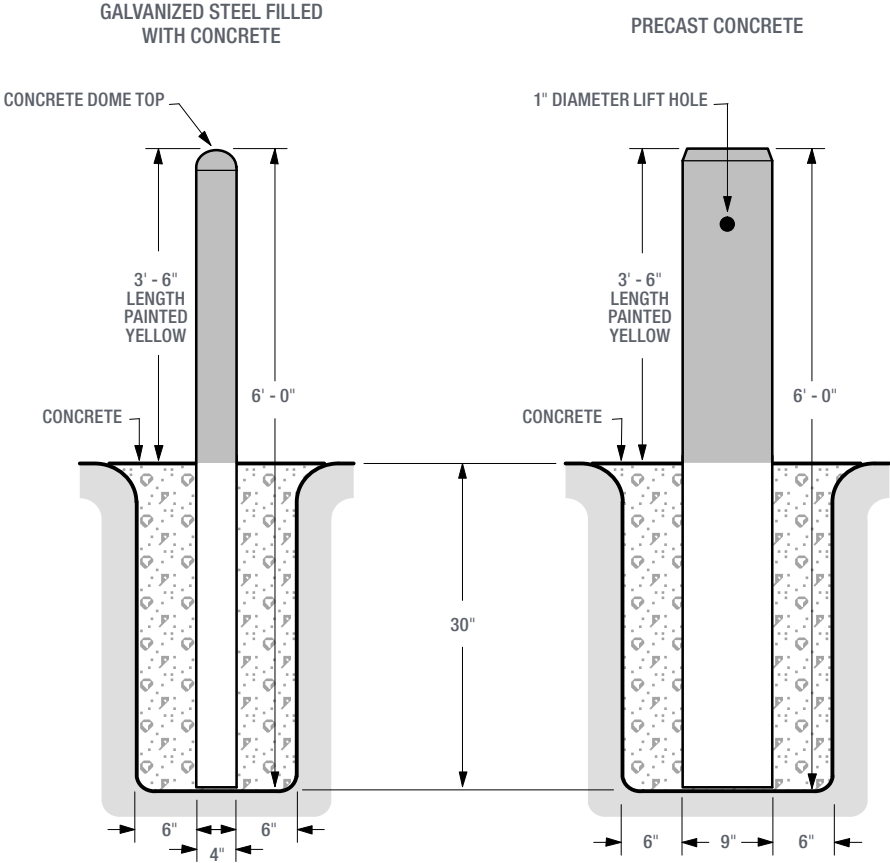
**Approved guard posts**

The following styles of guard posts are approved for PSE transformers:

- Schedule 40 or better galvanized steel pipe filled with concrete, 6 feet x 4 inches in diameter. The concrete shall have a minimum compressive strength of 3,000 psi after 28 days. The exposed section of the post shall be painted traffic yellow.
- Precast steel-reinforced concrete post, 6 feet x 9 inches in diameter. These posts are available from Utility Vault Company, Auburn, WA; or Hanson Inc., Tacoma, WA. The exposed portion of the post shall be painted traffic yellow.
- Set the post 30 inches deep in undisturbed soil. If soil has been disturbed, use concrete to stabilize the post.
- Backfill the holes with concrete.

Figure 15 illustrates both styles of guard posts.

**Figure 15** Typical guard posts



## Fault current levels

The most commonly used padmounted transformers installed by PSE are shown in Tables 5, 6, and 7.

The tables below also show the maximum available short-circuit current at the transformer's secondary connection point.

**Table 5** Maximum short circuit current (in amps) for single-phase transformers, padmounted

Type	Secondary Voltage	kVA	R/X	120 V Winding		240 V Winding	
				Min %Z	Fault Current	Min %Z	Fault Current
1-Phase PM	240/120	25	0.8	2.23	9300	1.7	6100
		37.5	0.7	2.23	14000	1.7	9200
		50	0.6	2.23	18700	1.7	12300
		75	0.5	2.34	26700	1.8	17400
		100	0.5	2.30	36200	1.8	23100
		167	0.5	2.43	57300	1.9	36600

**Table 6** Maximum short circuit current (in amps) for three-phase transformers, padmounted

Type	Secondary Voltage	kVA	R/X	Minimum %Z	3 Phase &/or L-G Fault Current
3-Phase PM	208Y/120	45	0.8	1.65	7600
		112.5	0.3	1.65	19000
		150	0.3	1.55	26900
		225	0.2	2.15	29100
		300	0.3	2.10	39700
		500	0.2	2.30	60300
		750	0.1	5.30	39300
		1000	0.1	5.30	52400
		480Y/277	45	0.8	1.65
	112.5		0.3	1.65	8200
	150		0.3	1.55	11600
	225		0.2	2.15	12600
	300		0.3	2.10	17200
	500		0.2	2.30	26100
	750		0.1	5.30	17000
	1000		0.1	5.30	22700
	1500		0.1	5.30	34000
	2000		0.1	5.30	45400
	2500	0.1	5.30	56700	

**Table 7**

Maximum short circuit current (in amps) for Y-Y grounded transformers

Type	Secondary Voltage	kVA	R/X	Minimum %Z	3 Phase &/or L-G Fault Current
Three 1-phase OH & UG Banks	208Y/120	30		2.10	4000
		45	0.9	2.00	6200
		75	0.8	1.70	12200
		112.5	0.7	1.70	18400
		150	0.6	1.70	24500
		225	0.5	1.80	34700
		300	0.5	1.80	46300
		500	0.5	1.90	73000
	480Y/277	30		2.10	1700
		45	0.9	2.16	2500
		75	0.8	1.90	4800
		112.5	0.7	1.70	8000
		150	0.6	1.70	10600
		225	0.5	1.80	15000
		300	0.5	1.80	20100
		500	0.5	1.90	31700
		1000		2.20	54600
		1500		2.30	78500

# Chapter 3

## Permanent overhead services

---

This chapter provides you with information on PSE's permanent overhead service installation. Please follow these requirements to avoid a delay in your service hookup. If you have any questions about this information, call Customer Construction Services (CCS) at **1-888-321-7779**.

### Service equipment installation responsibilities

---

<b>Puget Sound Energy</b>	PSE is responsible for furnishing, installing, and maintaining the primary system equipment, overhead service wire, current transformers (CT), meter(s), and meter wiring.
<b>Customer</b>	<p>You are responsible for furnishing, installing, and maintaining all required service entrance equipment, including the service entrance conductors from the meter base/socket or current transformer enclosure to PSE's designated point of delivery. The point of delivery for overhead service is at the connectors on the weatherhead.</p> <p>For services where CTs are required, you will also need to run conduit from the CT enclosure to the meter base. Refer to Chapter 4, Section 3, Current Transformer (CT) Metering Requirements (up to 800 A) for more information.</p>

### Preparing for your service hookup

---

The following list will help you prepare your project for the installation of an overhead service. After you complete these items, PSE will install the metering equipment and connect your service.

1. Check for any local ordinances/covenants that may prevent you from obtaining an overhead service.
2. Complete Electric Service Application Permanent Non-Residential 201E or Electric Service Multi-Family Development 400E. All forms can be downloaded at [pse.com/construction-services](http://pse.com/construction-services).
3. Supply site drawings and load information to your CCS Representative (refer to the Submitting an Application for Service section in Chapter 1).
4. Contact CCS to determine where your overhead service will originate.
5. Determine an approved meter location (refer to the Meter locations in Section 1, General Metering Requirements, of Chapter 4, Meter Installation).
6. Verify that the service mast height requirements have been met.
7. Provide and maintain a path, clear of obstructions, between PSE's pole and your service mast.
8. Provide payment for any preconstruction costs determined by your CCS Representative.
9. Install the required service equipment.
10. Provide and install service entrance conductors (leave a minimum of 18 inches exposed at the weatherhead).

11. Connect the meter bases/sockets and permanently label them to indicate the part of the premises they serve, such as unit number.
12. Obtain an approved electrical inspection.
13. Call CCS at **1-888-321-7779** to initiate connection and energize your new service.

## Service mast requirements

All requirements for the installation of the service mast are located in the National Electric Code (NEC) and the Washington Administrative Code (WAC) 296-46B. The following are PSE-specific requirements.

### Height requirements

PSE can assist you with determining the proper service mast height. Call CCS at **1-888-321-7779** for assistance.

### Clearances from gas meters

A minimum radial clearance of 3 feet is required between electric service equipment and the natural gas meter pressure relief vent.

### Additional mast supports

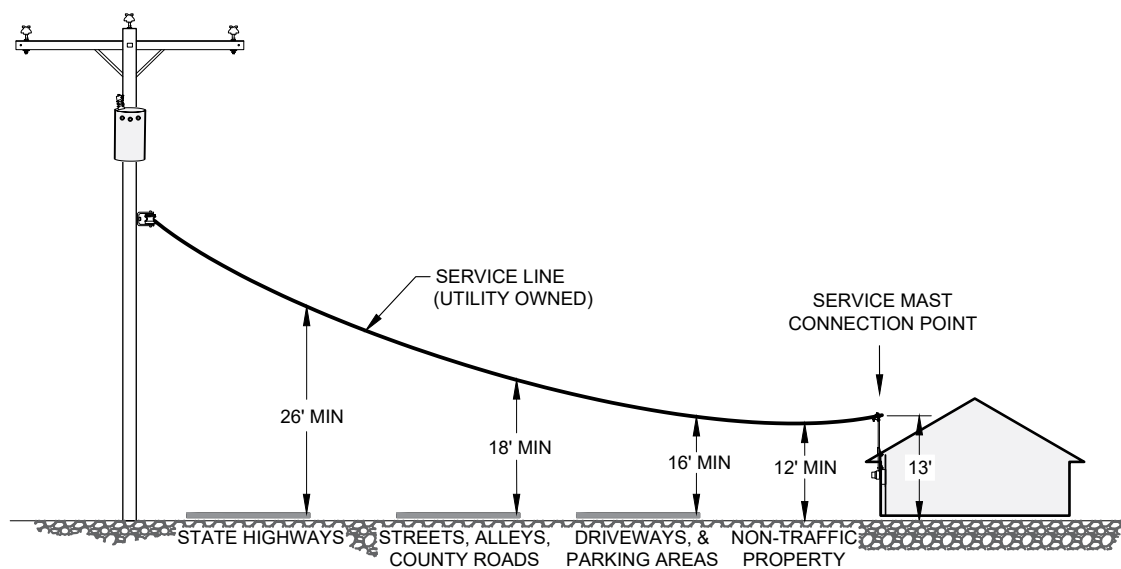
Additional mast supports, typically a guy or a brace, are required for any service line over 100 feet in length.

## Screw-in service knobs

For new or altered overhead service lines, you must provide a substantial point of attachment that meets NEC requirements.

Older screw-in type service knobs attached to the building's wall are often inadequate to support modern triplexed service lines. PSE may prohibit use of service knobs if deemed inadequate.

**Figure 16** Minimum clearance requirements upon installation



---

## Installing the service equipment

### List of customer-provided service entrance equipment

You are responsible for installing the following:

- Meter base/socket
- Current transformer (CT) enclosure and conduit between the meter base/socket, if required
- Service mast
- Insulated clevis for service attachment
- Service entrance conductor
- Ground rods

**NOTE:** PSE will install the service line and meter, as well as CTs and meter wiring if they are required.

### Terrain considerations for meter base/socket locations

Meter base/socket locations are covered in Chapter 4, Section 1 of this handbook. However, consider the type of terrain the electrical service line will cross when choosing a meter location. PSE strongly suggests avoiding service line routes that cross a driveway. Service lines crossing driveways can be hit by vehicles, causing damage to the service equipment or structure.

Contact CCS at **1-888-321-7779** for the minimum height clearance requirements of overhead service wires.

If the service line will pass through any trees, you are required to prune those trees to provide a clear path for the service line. You are also responsible for regular tree pruning, and if necessary, tree removal to keep the path clear.

---

## Customer-owned meter pole

### Meter pole requirements

If a meter pole is required for the project, it is your responsibility to purchase and install it. The meter pole must meet the following requirements:

- Be sound, round, or square, and made out of wood (commonly cedar or Douglas fir).
- Fully pressure treated. Verification from a PSE representative is required before installing the pole.
- Class 6 or better.
- 35 feet long minimum. **Exception:** With prior approval from a PSE representative, a meter pole of 20, 25, or 30 feet in length may be used (see the Minimum pole length requirement section) if the minimum conductor-to-ground clearances can be met (see Figure 16 for requirements).
- Minimum nominal diameter of 5-1/2 inches at the top (see the Service length section for the minimum pole size requirement).
- Butt gain cut 12 feet from the bottom of the pole. Nailing a washer to the pole at this location is acceptable as an alternative to having the gain pre-marked at the factory.

**NOTE:** Multiple meter installations shall be approved by PSE's Meter Department.

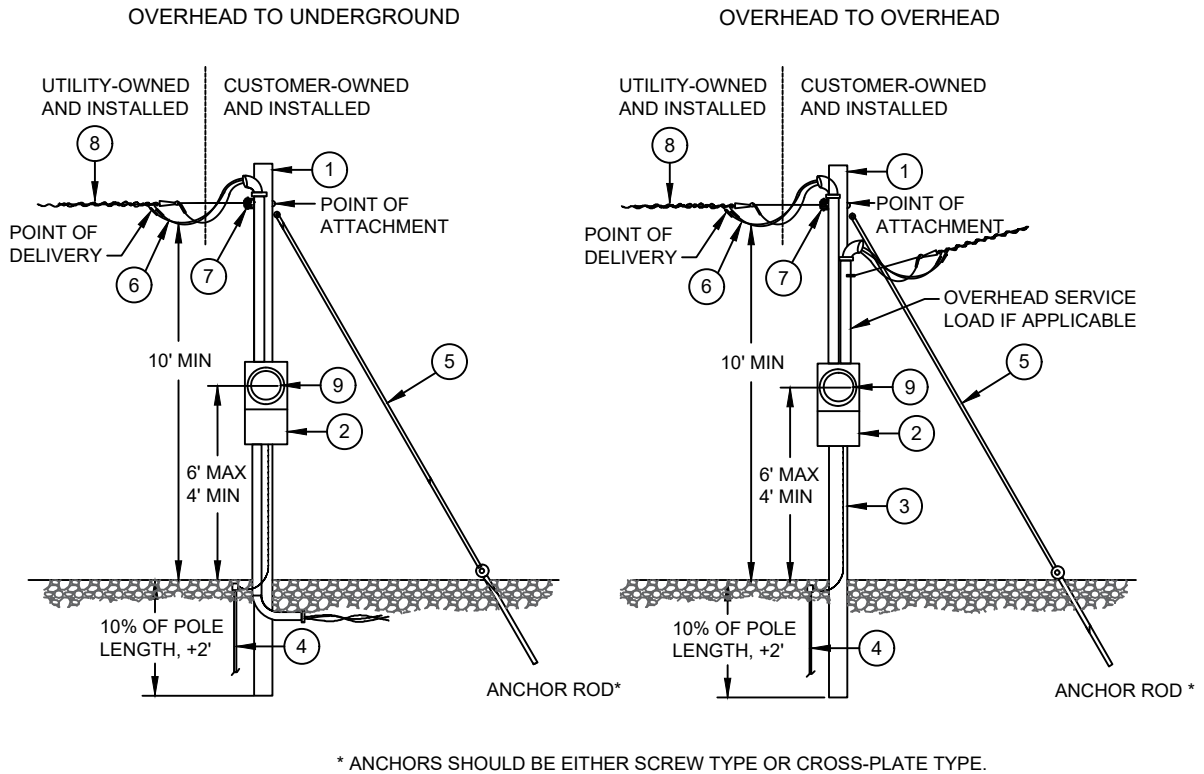
### Meter pole locations

Meter poles shall be:

- Accessible for reading and testing the meter.
- Located at a maximum distance of 150 feet from PSE's utility pole.
- Installed within 30 feet of the commercial building (typically).
- In an area that does not cross adjoining properties without obtaining easements.
- Approved by a PSE representative.

- Guying**
- A guy is required on all meter poles where the distance between PSE's pole and the meter pole is greater than 70 feet or the span crosses a public road. A push brace or pole key brace may be used if guy space is unavailable.
  - PSE engineering shall verify spans and guying for non-round poles.
- Setting**
- Meter poles shall be set at a minimum depth of 10% of the pole's total length plus 2 feet.
  - If soil conditions are poor, crushed rock can be used as a substitute for backfill.
  - The customer shall provide evidence of buried depth of pole to PSE by adding a butt-gain-type marker, such as nailing a washer to the pole at the location required. A PSE representative shall be able to see the butt gain upon field inspection.
  - A photo or means of evidence that the "gain" was installed on the pole at the correct location is the customer's responsibility. As an alternative, the customer can schedule an appointment with a PSE representative at the time to install the pole to allow PSE to inspect the correct depth of installation. Another alternative is for the customer to take a photo of the depth of bury with a measuring tape and provide it to PSE as evidence of compliance.
- Service length**
- Round and square timbers for a service length of less than 100 feet require a continuous, one-piece 6-inch by 8-inch minimum timber.
  - Poles with service length greater than 100 feet require a continuous, one-piece 8-inch by 8-inch minimum timber.
  - A PSE representative shall approve a service drop length exceeding 100 feet.
  - All pole-mounted service equipment shall be installed on standoff brackets to facilitate climbing.
- Minimum pole length requirement**
- If the meter pole is within 50 feet of a PSE power pole and the service conductor does not pass over a driveway or parking area, then:
    - » The minimum pole length of 20 feet is allowed with PSE approval.
  - If the meter pole is within 50 feet of a PSE power pole and the service conductor passes over a driveway or parking area; **or**,
  - If the meter pole is between 50 feet to 100 feet of a PSE power pole and the service conductor does not pass over a driveway or parking area, then:
    - » The minimum pole length of 25 feet is allowed with PSE approval.
  - If the meter pole is between 50 feet to 100 feet of a PSE power pole and the service conductor passes over a driveway or parking area; **or**,
  - If the meter pole is between 101 feet to 150 feet of a PSE power pole and the service conductor does not pass over a driveway or parking area, then:
    - » The minimum pole length of 30 feet is allowed with PSE approval.
  - If the meter pole is between 50 feet and 100 feet of a PSE power pole and the service conductor crosses over a city or county road or state highway; **or**,
  - If the meter pole is between 101 feet and 150 feet of a PSE power pole and the service conductor passes over a driveway or parking area; **or**,
  - If the meter pole is between 101 feet and 150 feet of a PSE power pole and the service conductor crosses over a city or county road or state highway, then:
    - » The minimum pole length is 35 feet.

Figure 17 Permanent overhead meter pole installation



Items owned and installed by customer	
1	Customer-owned meter pole
2	Meter base/socket
3	Ground wire, in accordance with NEC/WAC
4	Ground rods, in accordance with NEC/WAC
5	Down guy, 5/16" minimum diameter noncorrosive stranded steel wire required for services over 70 ft from PSE pole. Push brace or pole key brace may be substituted for down guy.
6	Service entrance conductors - 18" out of weatherhead
7	Insulated clevis

Items owned and installed by PSE	
8	Service line
9	Meter

# Chapter 4

## Meter installation

---

This chapter provides you with information on PSE's metering requirements. Please follow these requirements to avoid a delay in your service hookup. If you have any questions about this information, call Customer Construction Services (CCS) at **1-888-321-7779**.

**NOTE:** Services that require switchgear installation or CT metering require the approval of PSE Meter Engineering. A PSE Project Manager will coordinate this process.

Please see **Meter Socket Catalog Numbers (Form 7517)** for information on preapproved meter catalog numbers. It is located on PSE's [Construction Services Guides and Handbooks web page](#).

This chapter is divided into four sections:

### **Section 1: General metering requirements**

Meter installations requirements such as meter location, clearances, and multiple meter installations.

### **Section 2: Self-contained metering requirements**

For single-phase service 400 A or less, and three-phase services 200 A or less.

### **Section 3: Current transformer (CT) metering requirements (up to 800 A)**

For services up to 800 A and switchboard metering for services over 800 A.

### **Section 4: Primary metering requirements**

For 4.16 kV, 12.47 kV, and 34.5 kV single-phase and three-phase services (200 A and 600 A).

---

## Other contacts

If you have Net Metering or cogeneration questions please email [netmetering@pse.com](mailto:netmetering@pse.com).

## Section 1: General metering requirements

---

### Metering equipment responsibilities

Puget Sound  
Energy

PSE will furnish, install, and maintain the following equipment:

- Revenue meters
- Current transformers (CT)
- CT meter wiring
- The connectors where your service line interconnects with PSE's equipment.

<b>Customer</b>	<p>You will be responsible for furnishing, installing, and maintaining the following equipment (located beyond the point of delivery):</p> <ul style="list-style-type: none"> <li>• Meter bases/sockets</li> <li>• All necessary wiring and connections (except CT meter wiring)</li> <li>• Switches</li> <li>• Enclosures</li> <li>• Gray electrical conduit</li> <li>• Protection equipment</li> </ul>
-----------------	--

---

### Other customer responsibilities

<b>Installing or removing meters by a qualified electrician</b>	<p>Only authorized and qualified PSE personnel shall cut seals and remove or install meters.</p> <p>However, under emergency conditions, exceptions may be granted to qualified electricians by contacting CCS at <b>1-888-321-7779</b> Monday through Friday, 7 a.m. – 5 p.m. Outside of these hours, please call Customer Service at <b>1-888-225-5773</b>.</p> <p>When this occurs, the qualified electrician shall accept all liability for damage or alteration to equipment, injury to persons or property, and loss of revenue to PSE from the time the seal is removed until 72 hours after PSE has been notified that the equipment is ready to be resealed. The customer or contractor shall promptly notify PSE when repairs or modifications are complete.</p> <p><b>WARNING:</b> Use extreme caution when removing and installing meters. Depending upon the type of service or meter base, removal of the meter does not necessarily de-energize service.</p>
<b>Inspections and approvals</b>	<p>Before a new service is energized, the installation shall be inspected and approved by the governing city or state electrical inspector.</p>
<b>Sealing provisions on enclosures</b>	<p>CT enclosures, switchgear, gutters that contain unmetered conductors, and metering equipment shall have provisions for sealing.</p>
<b>Service conductors</b>	<p>Metered circuits shall not enter raceways or enclosures containing unmetered circuits, except for meter loops on poles.</p> <p>All conductors shall be securely fastened in their terminals. Aluminum conductor connections require corrosion inhibitor (electrical joint compound).</p>
<b>Grounding</b>	<p>All meter bases/sockets, enclosures, and conduit shall be bonded and grounded in accordance with Articles 230 and 250 of the latest edition of the NEC.</p> <p>When self-contained meter bases/sockets are used, the neutral conductor shall be connected to the neutral terminal in the socket.</p>

<b>Labeling</b>	<p>Where multiple meters or remote meters are installed, meter base/sockets shall be permanently labeled to indicate the address they serve. PSE requires engraved phenolic nameplates or adhesive die-cut labels at least 1 inch high, with raised or cut-out lettering that is a minimum of 3/4 inch high. All lettering should be capitalized. Service will not be established until marking is complete.</p> <p><b>NOTE:</b> Felt-tip pens and label maker tape are not considered permanent marking.</p>
<b>Customer equipment</b>	<p>The customer's load monitoring equipment shall be installed only on the load side of PSE's metering. No customer equipment shall be allowed inside a meter or current transformer enclosure. This includes customer load monitoring and control devices and any other customer owned equipment.</p> <p><b>NOTE:</b> Meter base/socket and current transformer enclosures shall not be used as a junction box.</p>
<b>Current-limiting fuses</b>	<p>Current-limiting fuses to protect the customer's electrical system from high fault current shall not be installed in meter bases/sockets, instrument transformer enclosures, or PSE's distribution transformers. They may be installed in the customer's service panel or in a separate enclosure between the socket and the panel. Current-limiting fuses are not allowed ahead of the meter or CT enclosure.</p>

---

## Meter locations

<b>Location requirements</b>	<p><b>NOTE:</b> Contact your PSE Project Manager or CCS to initiate the PSE Meter Engineering review and approval process. All meter locations shall meet the requirements written in this handbook.</p> <p>You are required to provide a location to install metering equipment. The meter location must be free from obstruction, corrosive atmosphere, and abnormal temperature or vibration, and must be convenient to PSE's distribution system.</p> <p>All meters, instrument transformers, and PSE-owned meter equipment shall be installed at ground-level locations (except for high-rise residential structures) that are accessible 24 hours a day, 7 days a week, for meter reading, maintenance, and installation or removal.</p> <p><b>NOTE:</b> Mezzanines are not considered to be at ground level and are not acceptable for the location of PSE meter equipment.</p> <p>The meter base/socket shall be installed outside on schools, churches, halls, or other similar structures that may be locked during normal business hours.</p>
<b>Prohibited locations</b>	<p>Meters or metering equipment shall not be installed at any of the following locations:</p> <ul style="list-style-type: none"> <li>• Below the first level of a building.</li> <li>• In commercial occupancies they do not serve.</li> <li>• Any place where safety may be compromised.</li> <li>• On poles owned by PSE.</li> <li>• On any line pole occupied solely by the telephone company, except to serve telephone company equipment.</li> </ul>

**Meter location requirements for manufactured commercial structures (school portables, industrial modular office, etc.)**

If you are installing an overhead service to a manufactured commercial structure, our service equipment can be installed on the manufactured commercial structure or on a customer-owned meter pole.

Meter bases/sockets installed on manufactured commercial structures are required to be:

- Located on an outside wall of your structure and accessible for reading and testing.
- Installed 4 to 6 feet above finished grade with a service mast that meets NEC requirements.
- The proper type for the service (see Table 8).

Meter bases/sockets must not be installed:

- In a breezeway.
- In an area that is subject to being fenced.

---

## Electrical room requirements

Meter bases/sockets, where an exterior location is not available for metering equipment and CT enclosures, must be located inside an electrical room that shall be used solely for power and communication equipment and fire equipment as required by NEC. The electrical room must be located on the first/lobby level (main entrance) or the level of the parking garage closer to the entrance.

**NOTE:** The electrical room walls must be in permanent construction. The electrical room shall be accessible 24 hours a day, 7 days a week. Additionally, the equipment room shall be well lit and not used for storage. All electrical room requirements must be met before PSE installs meter(s).

You must provide the following:

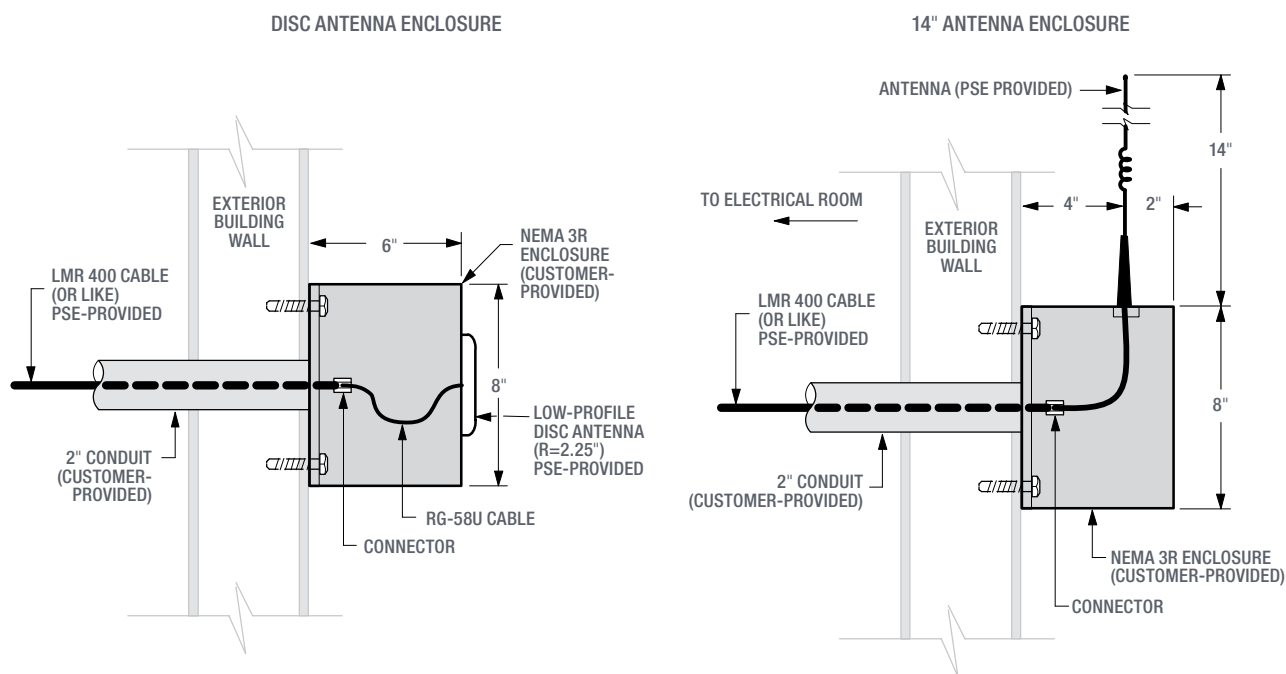
- **Door.** A door, equipped with panic bars, that leads directly to the outside of the building, loading dock, or with prior approval from the PSE Meter Engineering, directly to a publicly accessible lobby of the structure's main entrance that is not restricted by security. The size of the door shall be a minimum of 2 feet 8 inches x 6 feet 8 inches.
- **Keybox.** A location within 6 inches of the electric meter room door for the installation of a keybox, a key fitting the electrical room door for the keybox, and a sign on the exterior of the door stating "Electrical Room." If multiple electrical rooms are needed, each electrical room door shall have a dedicated keybox with key.

**NOTE:** If door locks are changed, it is your responsibility to contact CCS to coordinate the exchange of new keys.

- **Conduit for AMR/AMI antenna.** A 2-inch gray PVC conduit, from each electrical room to a NEMA 3R enclosure on the exterior of the building used for the automated meter reading (AMR/AMI) antenna.
  - » The conduit shall have a maximum of 360 degrees in total bends and be no more than 25 lineal feet total length.
  - » If a single meter is installed within the electrical room, the total length of the conduit may be extended to 70 lineal feet.
  - » Contact CCS if the conduit length is greater than 25 feet.
  - » Antenna enclosure requirements are shown in Figure 18.
  - » A 1/8 inch minimum pull string is to be provided in the conduit.

- Conduits for AMR/AMI antenna shall be labeled “PSE Use Only” in meter room(s).
- **Conduit pathway for high-rise residential only.** If the building has multiple aboveground electrical rooms where meters are located, a 2-inch PVC conduit pathway connecting all of the equipment rooms shall be provided for the AMR/AMI antenna cable.
  - » From the top level electrical room, provide a 2-inch conduit to a NEMA 3R enclosure mounted on the roof of the building.
  - » Mount the enclosure above the building facade and other obstructions. Preferred locations are adjacent to or on top of the rooftop mechanical room or within antenna farm locations (see Figure 18).
- **NEMA 3R antenna enclosure.** A NEMA 3R antenna enclosure shall be located on the first story outside wall 8 to 10 feet aboveground for buildings with one electrical room.
- **2-foot-square piece of 3/4-inch plywood.** A 2-foot-square piece of 3/4-inch plywood shall be mounted on the wall of the electrical room for an AMR/AMI repeater. Mount the plywood 4 to 6 feet above the floor near the antenna conduit entry location into the room. Provide a dedicated 120 V receptacle adjacent to the plywood.

**Figure 18** Typical 8 in. x 8 in. x 6 in. exterior wall-mounted AMR/AMI antenna installations



---

## Electrical room locations in high-rise buildings

Electrical rooms in high-rise\* buildings shall be coordinated with PSE Meter Engineering during the design stage of construction, and approved prior to construction.

\* PSE will consider buildings five stories and taller as “high-rise” for the purposes of this section.

If a high-rise building project qualifies for allowing PSE metering beyond a customer transformer, (typically a dry type 480/208 volt); a transformer loss billing agreement must be completed per PSE Standard 6325.3370 prior to PSE meter installation.

---

## Meter bases/sockets

### General requirements

Meter bases/sockets and enclosures shall be acceptable to PSE, accepted by an approved testing laboratory, and must fulfill these requirements:

- All meter bases/sockets shall be ring-type and shall include either a screw-type locking ring (preferred) or a stainless steel snap ring.
- Sockets for nonresidential loads require a manual block bypass. Automatic circuit closures or lever bypasses are not acceptable.
- Any meter base/socket containing energized equipment shall be covered and sealed with a transparent cover plate if a meter is not installed.
- Meters shall be installed only in sockets that are level, plumb, and securely fastened to the structure.
- Meter base/sockets shall be permanently labeled to indicate the address they serve. PSE requires engraved phenolic nameplates or adhesive die-cut labels at least 1 inch high and lettering a minimum of 3/4 inch high. Service will not be established until marking is complete.

**NOTE:** Felt-tip pens and label maker tape are not considered permanent marking.

- All unused openings of the meter base/socket enclosure shall be closed with plugs that are secured tightly in place from inside the enclosures before a meter is installed.
- All meter equipment exposed to weather shall be raintight according to the National Electrical Manufacturer’s Association (NEMA) 3R minimum.
- Terminals shall be marked with a conductor range for aluminum or copper conductors. When aluminum conductors are used, the socket must be approved and clearly marked by the manufacturer for that use.
- CT enclosures, switchgear, gutters that contain unmetered conductors, and metering equipment shall have provisions for sealing.

**CAUTION:** Strands shall not be removed to make conductors fit undersized terminals. Meter bases/sockets shall not be jumped to provide power.

### Determining meter base/socket type

To determine meter base/socket types for specific voltages and amperage ratings use Table 8.

### Meter base/ socket clearances

**NOTE:** The center of the meter base/socket is always the point of reference.

For...	Clearance
Base/Socket height	Meter base/socket height shall be 4 feet minimum to 6 feet maximum above finished grade or floor (see Figure 19). For any meter base in a flood zone, a raised platform may be required in order to allow PSE access and to meet the height requirement in Figure 19.
Working space	<ul style="list-style-type: none"> <li>• Working space in front of metering equipment not installed in switchgear (including current transformer enclosures) shall be at least 3 feet wide and 3 feet deep, measured from the front of the enclosure or meter face (see Figure 19). Plants, shrubs, and trees shall not be planted in this space.</li> <li>• Working space in front of PSE metering equipment installed in switchgear shall be at least 6-feet deep and extend the full width of the section containing PSE equipment (see Figure 20).</li> <li>• All meter locations must maintain 6-feet of worker headroom.</li> <li>• The center of all meter base/socket enclosures shall be a minimum of 18 inches from adjacent walls, ceilings, or other similar obstructions (see Figure 19).</li> <li>• All service equipment, including disconnect switches, shall be a minimum of 10 inches from the meter's center.</li> <li>• Building siding shall not cover or overlap the meter base/socket.</li> </ul>
Minimum clearance from gas meter	The diagrams and the measurements provided in Gas and Electric Underground Service Installation Requirements show the required minimum distances between building features and the relief vent.
Recessed meters	When a meter base/socket enclosure is recessed in the building wall, a flush-type socket is required and mounted flush with the exterior wall. Recessed meter bases/sockets require a clearance of 10 inches in all directions between the center of the meter and the closest portion of the wall (see Figure 21).

Figure 19 Meter base/socket minimum clearances, without switchgear

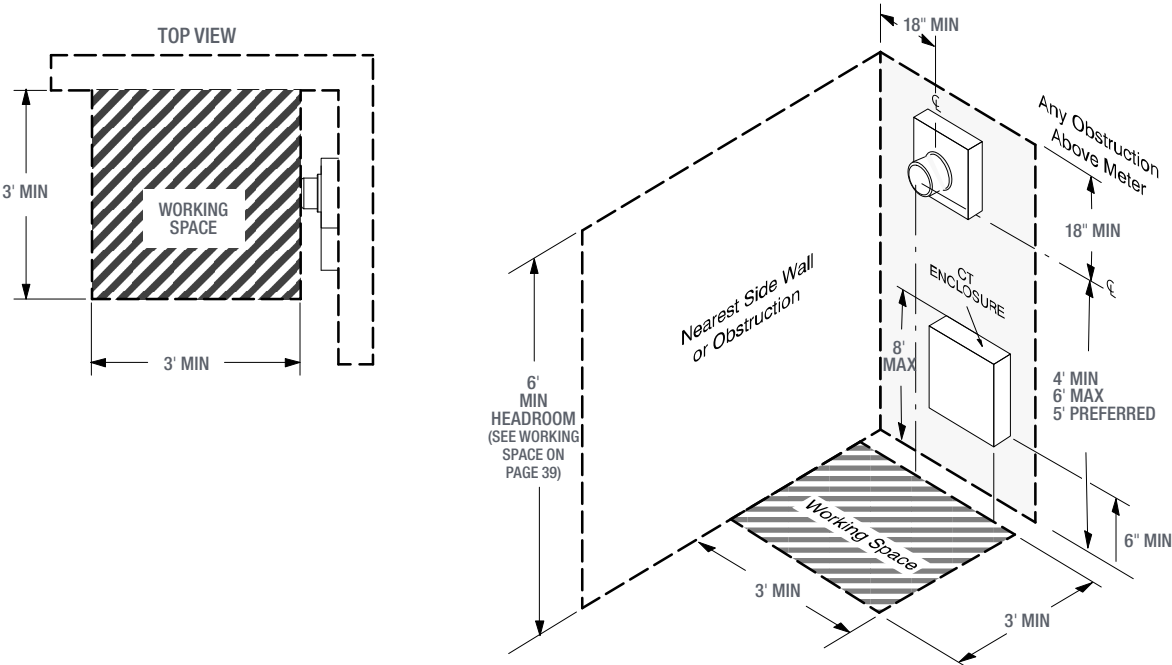


Figure 20 Switchgear installed meter and current transformer minimum clearances

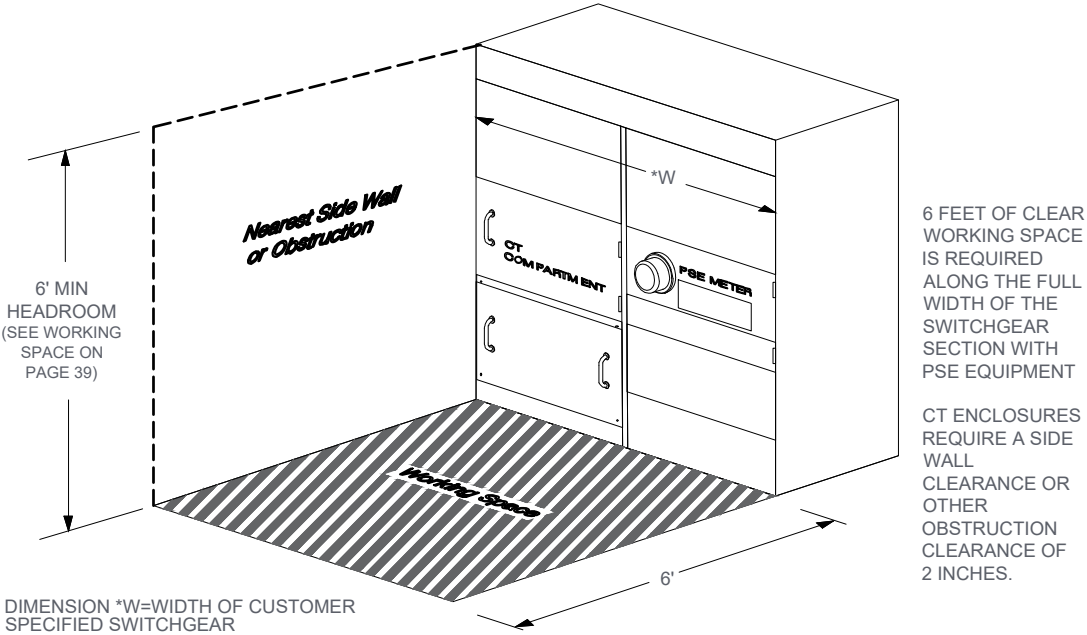
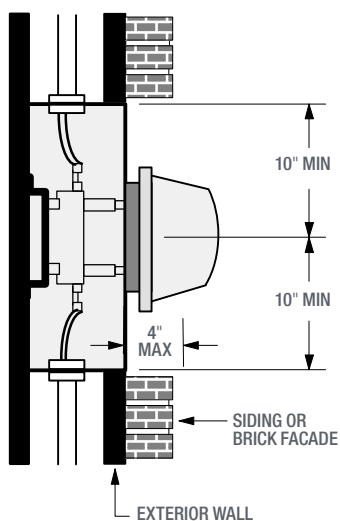


Figure 21 Minimum clearances for recessed meters



## Remote metering

Normally, a meter base/socket and associated devices (current transformers, etc.) are attached to a permanent or fixed structure, such as a building, that contains the load being served. Remote metering is allowed if there is no permanent or fixed structure for the load, or when otherwise agreed to by PSE Meter Engineering.

Remote metering consists of a meter on a meter pedestal. Safe parking must be located within 50 feet of the meter.

All remote metering requires PSE Meter Engineering approval before construction begins. Contact CCS if you require remote metering.

### Meter pedestal requirements for remote metering

Meter pedestals must meet the specifications of EUSERC Section 300 (Metering and Service Equipment 0 – 600 V), and drawings 308, with the following additional specifications for the meter base/socket:

- The meter base/socket shall meet all requirements according to the service voltage and amperage as required in this handbook.
- The test/bypass safety disconnect shall meet EUSERC drawings 311 or 312.
- Enclosed metering for protection from vandalism must meet EUSERC drawings 300 and 308 and PSE pedestal clearance and socket requirements. Installations that do not meet these requirements will need written permission from PSE Meter Engineering to proceed.
- Drawings shall be submitted for approval by the manufacturer, noting the EUSERC and PSE drawings and specifications used.
- Meter pedestals shall be on structures such as masonry, concrete, or metal.
- Meter pedestals exposed to vehicular traffic (other than those used for traffic management loads) shall be protected by guard posts as described in the Guard posts for padmount and subsurface equipment section in Chapter 2, Permanent Overhead Services.

### Meter pedestal location

The metering pedestal must be located so that the access for the metering and pull section are free of surrounding obstructions, with at least 36 inches of working space clearance surrounding the equipment.

Safe parking shall be available within 50 feet of the meter.

### Remote service requirements based on service ampacity

- Remote services 800 A or less for nonresidential loads shall be mounted on permanent support structures that are made of galvanized steel pipe with unistrut cross-braces, concrete, or masonry blocks. Support structures made of wood (treated or not) are unacceptable.
  - » The customer shall provide a 3-foot x 3-foot x 3-inch-thick concrete pad surrounding the meter or holes 2 feet deep that are filled with concrete to anchor the structure.
  - » The minimum height of the meter shall be 3 feet.
  - » Other requirements specified in this handbook for meter bases/sockets and CT enclosures apply.
- Remote services greater than 800 A – Remote services 800 A or greater require EUSERC outdoor switchgear. Ask your CCS Representative for more information.

### Labeling

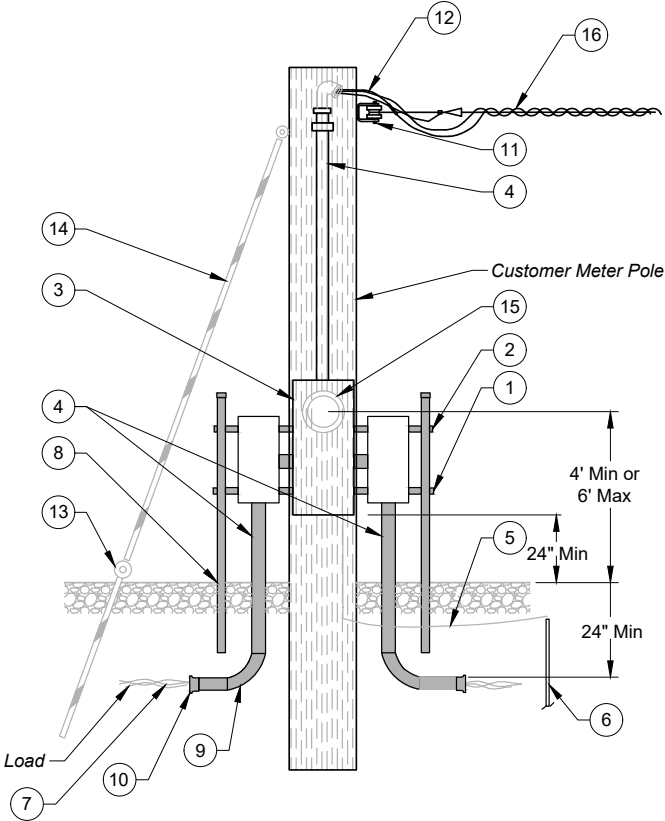
Where multiple meters or remote meters are installed, meter base/sockets shall be permanently labeled to indicate the address they serve. PSE requires engraved phenolic nameplates or adhesive die-cut labels at least 1 inch high, with raised or cut-out lettering that is a minimum of 3/4 inch high. All lettering should be capitalized. Service will not be established until marking is complete.

**NOTE:** Felt-tip pens and label maker tape are not considered permanent marking.

### Highway lighting metering and disconnect

If the disconnect is not visible and placed inside the metering cabinet, place a permanent label stating “Disconnect inside the cabinet” on the metering cabinet cover. PSE requires engraved phenolic nameplates or adhesive die-cut labels at least 1-inch high.

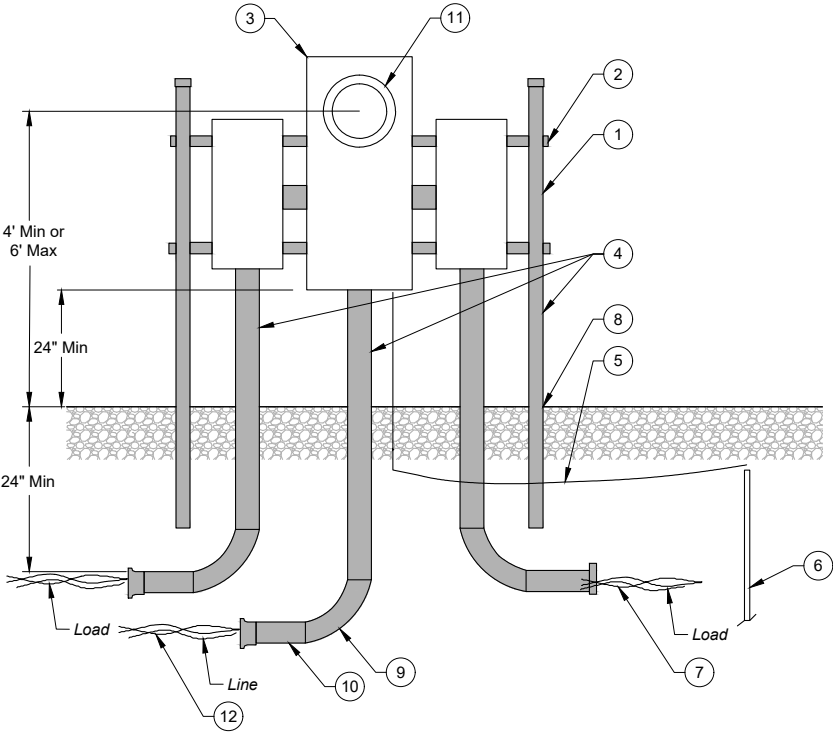
Figure 22 320 Amp meter on customer service pole detail



Items owned and installed by customer	
1	Galvanized steel pipe
2	C-channel (unistrut) cross bracing
3	Service entrance equipment
4	Service conduit, in accordance with NEC/WAC
5	Ground wire, in accordance with NEC/WAC
6	Ground rod(s), in accordance with NEC/WAC
7	Service conductor to building/residence
8	Holes 2' deep filled with concrete to anchor panel
9	Elbow, 90° bend, 24" min radius
10	Bell end
11	Rigid clevis
12	Service entrance conductors, 18" out of weatherhead. Required for service distances greater than 70' or when span crosses road (also customer owned/installed).
13	Anchor (plate or screw type)
14	Down guy, 5/16" minimum diameter non-corrosive stranded steel wire. Push brace or pole key brace may be substituted for down guy.

Items owned and installed by PSE	
15	Meter
16	Customer service line

Figure 23 320 Amp underground remote permanent meter detail



Items owned and installed by customer	
1	Galvanized steel pipe
2	C-channel (unistrut) cross bracing
3	Service entrance equipment
4	Service conduit, in accordance with NEC/WAC
5	Ground wire, in accordance with NEC/WAC
6	Ground rod(s), in accordance with NEC/WAC
7	Service conductor to building/residence
8	Holes 2' deep filled with concrete to anchor panel
9	Elbow, 90° bend, 24" min radius
10	Bell end

Items owned and installed by PSE	
11	Meter
12	Customer service line

## Multiple meter installations

### Multifamily

PSE will need a confirmation letter from the governing body, city, or fire department, approving the unit numbers for apartment complexes (4 or more units) before PSE verifies the units by performing the meter ring out (MRO). The MRO verifies that the meter sockets are correctly labeled and that they serve the corresponding units.

On residential multimeter panels, the minimum spacing between socket centers shall be 7-1/2 inches horizontally, 8-1/2 inches vertically, and the center line shall be a minimum of 3 feet and a maximum of 6 feet above the floor or finished grade. This configuration allows for five (5) vertical sockets maximum.

Multimeter installations serving residential living units shall comply with the equipment arrangement requirements are shown in Figure 24.

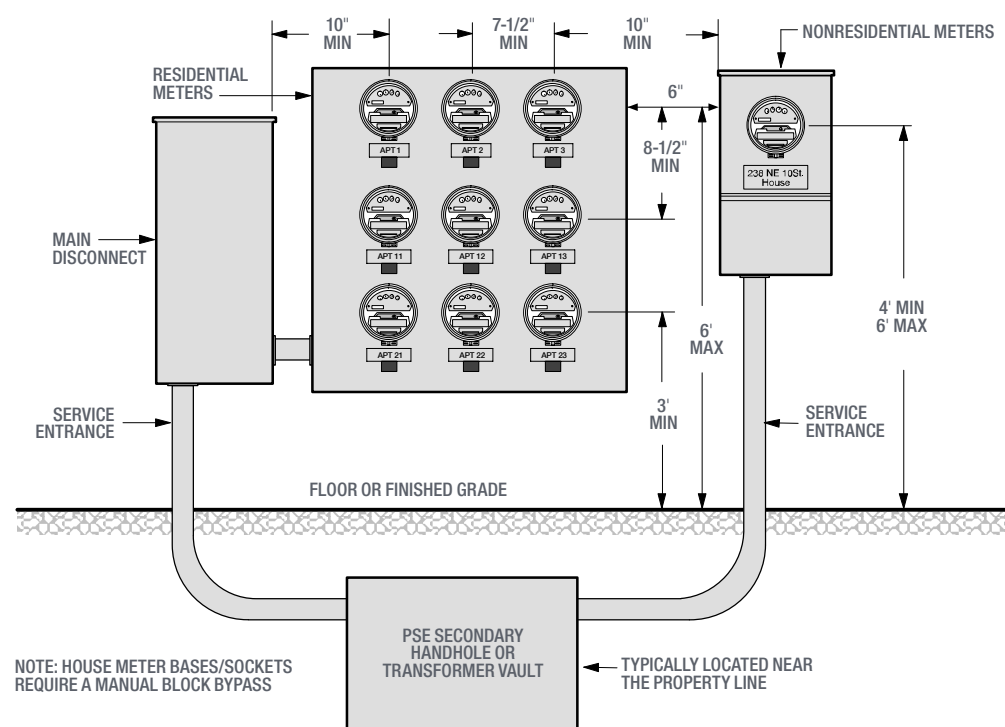
Meter base/socket jumpers shall not be used to serve house meters. House meters shall be served in the following ways:

- A dedicated set of service entrance conductors.
- A tap on the bussing of residential multimeter panels.
- All-in-one factory assembled multimeter panels.

**NOTE:** PSE requires house meters to have manual block bypasses.

Figure 24

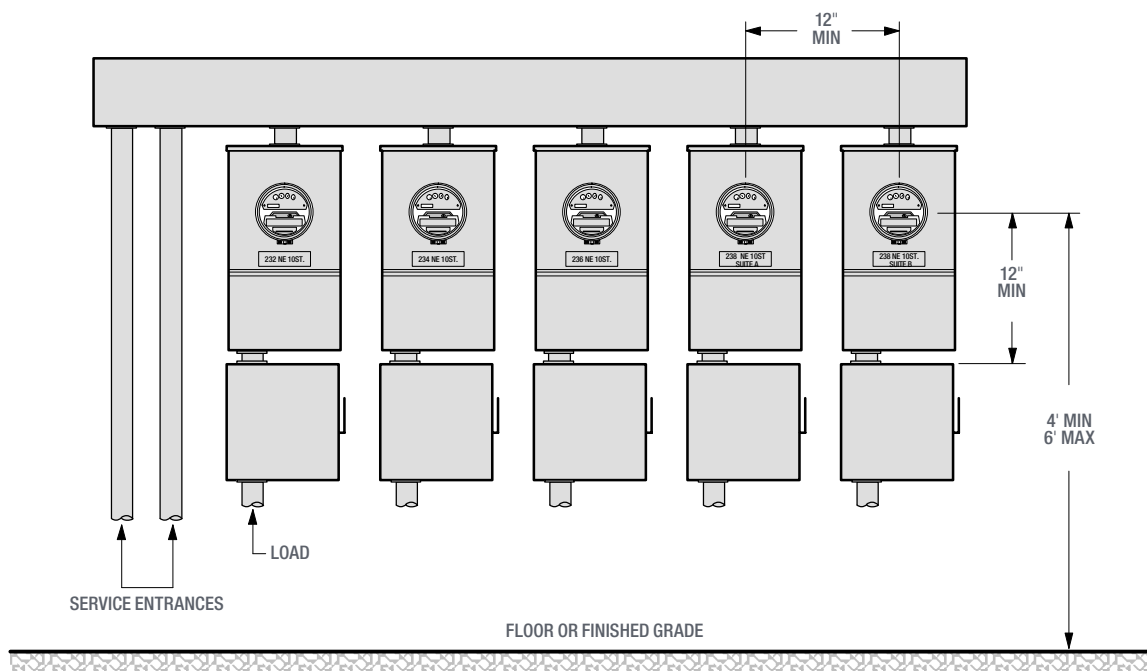
Typical factory-built residential multimeter panel for multifamily complex



**Nonresidential** On nonresidential multiple meter panels, the minimum spacing between socket centers shall be 12 inches horizontally, 12 inches vertically, and the meter shall be a minimum of 4 feet and a maximum of 6 feet above the floor or finished grade.

Meters shall be adequately protected from mechanical damage. Factory-built multiple meter equipment shall be approved by the PSE Meter Engineering. A typical example of a nonresidential multiple meter installation is shown in Figure 24.

**Figure 25** Typical multiple nonresidential meter installations for services 200 A or less



**NOTES:**

Clearances in this drawing (nonresidential) also apply for factory-built multiple meter panels, except that meters may be a minimum of 4 feet above floor.

Meter bases/sockets require a manual block bypass.

More than six meters requires a main disconnect per NEC.

277/480 V series shall have a service disconnect ahead of each meter and a safety socket.

**Multiple meter base/socket labeling**

Meter bases/sockets shall be permanently labeled to indicate the part of the premises they serve (i.e., unit number). PSE requires engraved phenolic nameplates or adhesive die-cut labels at least 1 inch high. Service will not be established until marking is complete.

**NOTE:** Felt-tip pens and label maker tape are not considered permanent marking.

## Section 2: Self-contained metering requirements

---

### Single-phase services: 400 A or less and three-phase services: 200 A or less

---

#### Meter base/socket main disconnect combinations

Meter base/socket and circuit breaker combinations are acceptable for 0–320 A, single-phase, and 0–200 A, three-phase services, provided the meter base/socket section meets PSE’s manual block bypass, sealing, equipment sequence, and dimensional requirements.

#### Manual block bypass requirements

All self-contained nonresidential meter bases/sockets (except single-phase temporary services and Rate Schedule 8) require a manual block bypass (see Table 8). Automatic circuit closures or lever bypasses are not acceptable.

**NOTE:** Schedule 8 is used for single-family customers that have a separate service for well pumps (serving no more than two residences), barns, outbuildings, or other loads on the same property as the residence. For this type of service PSE will install the secondary service line.

#### Disconnecting means and its sequence

All services with self-contained meters shall have the meter ahead of the disconnect switch, except for 277/480 V services, where the safety disconnect is ahead of the meter. The safety disconnect must be collocated within 5 feet of the meter. A fused disconnect is preferred.

Each meter shall have a corresponding disconnect. A single disconnect is not permitted for multiple meters.

Single-phase 480 V streetlight metering requires a disconnect ahead of the meter.

#### Safety sockets

A safety socket is required for self-contained 480 V sockets (see Table 8).

---

#### Load balancing

When 120/208 V, three-phase transformers provide single-phase service, it is your responsibility to identify the service conductors and balance the load on the transformer.

---

#### Service conductor connections

Service conductor connections should meet these requirements:

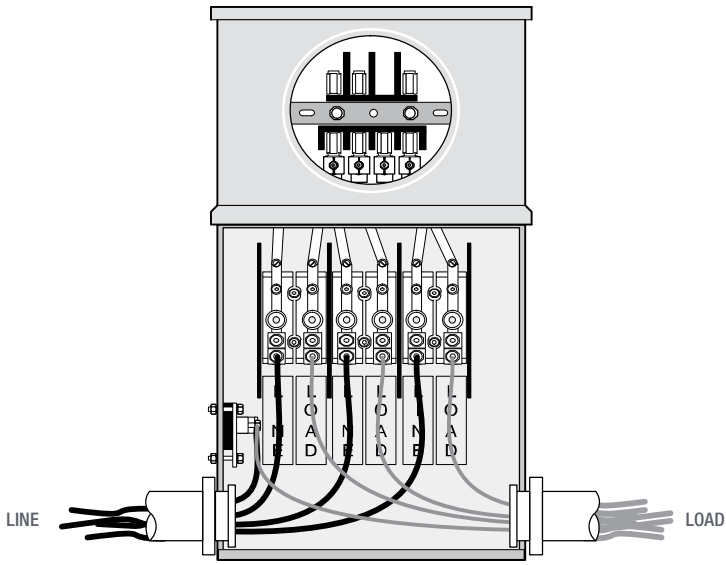
- Line-side conductors shall always be connected to the top terminals of the meter base/socket.
- You are responsible for ensuring that the connection of service entrance conductors in the meter base/socket are inspected and tightened before the service is energized.
- Where safety sockets are used, circuit-connecting nuts shall be properly torqued (see Figure 25).

**NOTE:** Meters will not be installed unless these connections are tight.

- Meters will not be installed if conductors place undue strain on the terminal facilities.
- Terminals shall be rated for the size of conductor to be used.
- Service conductors shall be arranged in the socket to avoid interfering with the meter installation or operation of the manual block bypass (see Figures 26–28).

**CAUTION:** Strands shall not be removed to make conductors fit undersized terminals.

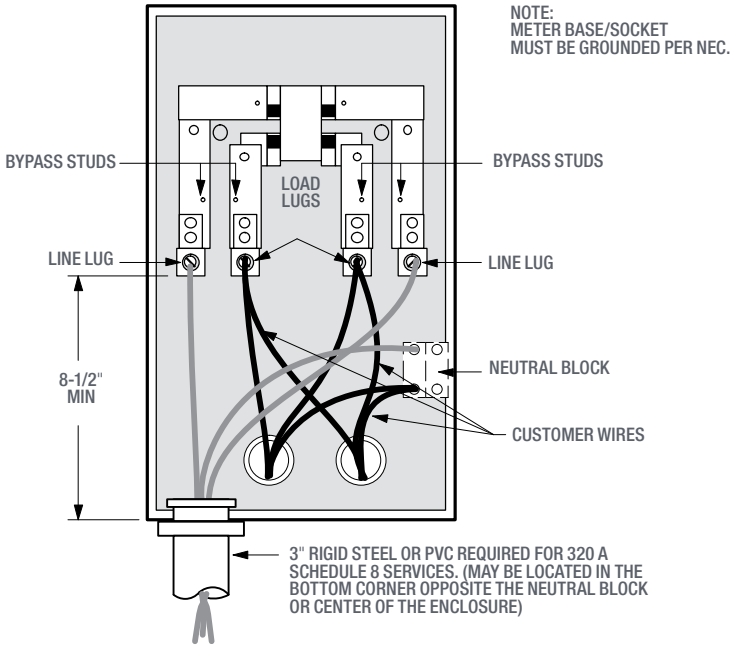
Figure 26 Typical safety socket



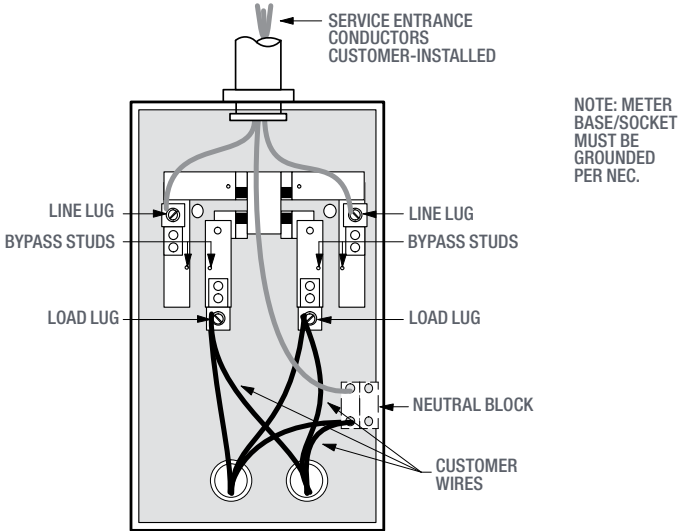
**NOTE:** All 277/480 V self-contained meters 200 A or less shall have an accessible disconnecting means ahead of each meter(s); a fused disconnect is preferred.

**NOTE:** In three-phase delta 120/240 V services, the high leg shall be only on the right side of the meter base.

Figure 27 Typical arrangement of service conductors for underground commercial single-phase 320 A service

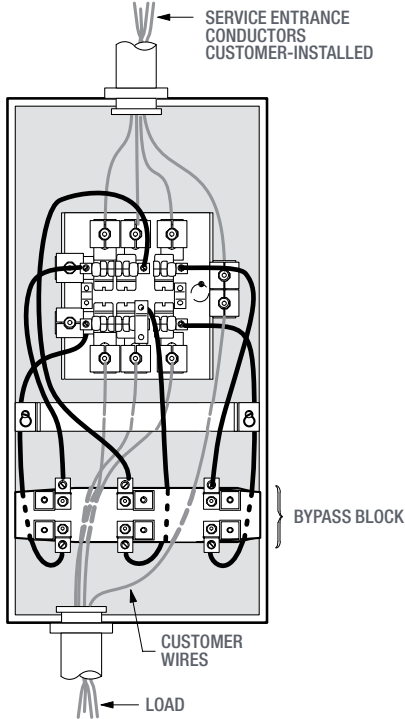


**Figure 28** Typical arrangement of service conductors for overhead commercial single-phase 320 A service



**NOTE:** Line lugs shall be turned 180° to allow proper insertion of wire and to keep from blocking bypass area.

**Figure 29** Typical arrangement of service conductors for 120/208 V three-phase self-contained 200 A service



**NOTE:** Service wires shall be installed behind bypass block so operation of bypass is not restricted.

**NOTE:** In three-phase delta 120/240 V services, the high leg shall be only on the right side of the meter base.

---

## Self-contained meter base/socket requirements

<b>Single-phase services: 400 A or less</b>	A manual block bypass is required on all commercial services. Automatic circuit closures, sliders, and lever bypasses are not acceptable.
<b>Single-phase services: 120/240 V, 200 A or less</b>	A self-contained meter base/socket shall be installed on all new and remodeled single-phase services (120/240 V), where the current-carrying capacity of the service entrance conductors does not exceed 200 A, as specified in NEC (see Table 8, Meter Base/Socket Configuration A).
<b>Single-phase services: 201 to 400 A</b>	Two options are available: <ol style="list-style-type: none"> <li>1. A self-contained 320-A meter base/socket with a manual block bypass is required on all new and remodeled single-phase services (120/240 V) over 200 A, where the current-carrying capacity of the service entrance conductors does not exceed 400 A, as specified in the NEC (see Table 8, Meter Base/Socket Configuration A).</li> <li>2. Current transformer metering is available at additional cost; contact PSE's CCS office (see Table 8, Meter Base/Socket Configuration B).</li> </ol>
<b>Single-phase services: 120/208 V, 200 A or less</b>	A 5-terminal meter safety socket shall be installed where the fifth terminal is placed in the nine o'clock position connected to the socket neutral bus conductor (see Table 8, Meter Base/Socket Configuration C).
<b>Single-phase streetlight services: 120/240 V or 240/480 V pedestals</b>	A 5-terminal meter safety socket shall be installed where the fifth terminal is placed in the nine o'clock position connected to the socket neutral bus conductor (see Table 8, Meter Base/Socket Configuration C). Flat rated services do not require a meter safety socket. <b>NOTE:</b> All 240/480 V services require an accessible disconnect ahead of the meter. A fused disconnect is preferred.
<b>Meter/panel combo units</b>	For overhead service, meter/panel combo units must meet the requirements in Chapter 3.  For underground service, these units must meet the requirements Chapter 2, unless the line side conductors terminate below the meter base. If line side conductors terminate below the meter base and are bussed up to the top jaws, the minimum dimension for width and height is no longer required.  <b>NOTE:</b> If using this type of service equipment, please check with your local or municipal inspector to determine if it meets updated NEC 2020 codes for disconnects. PSE requires this type of equipment to be hot sequenced and does not allow a disconnect ahead of the meter socket.

---

## Three-phase services: 200 A or less

### All three-phase services

A manual block bypass is required on all commercial services. Automatic circuit closures, sliders, and lever bypasses are not acceptable.

The neutral (grounded conductor) shall be connected or tapped to the third terminal from the left on the lower terminals (see Table 8, Meter Base/Socket Configuration D).

### Three-phase services: 120/240 V, four-wire delta (Restricted — available only for existing services)

In addition to the requirements for all three-phase services, the high-leg (power leg) shall be connected through the right-hand terminals of the socket.

### Three-phase services: 277/480 V

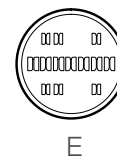
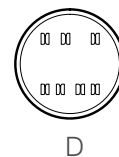
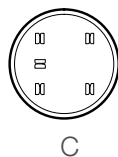
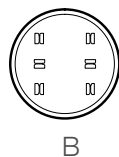
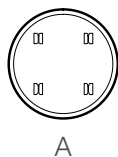
An accessible disconnect (fused disconnect preferred) ahead of each meter base/socket and a safety socket with a manual bypass are required. Disconnect must be co-located within 5 feet of the meter.

**NOTE:** Be familiar and comply with the customer equipment restrictions provided in Section 1, Other customer responsibilities of this chapter.

**Table 8** Single-phase (nonresidential only) and all three-phase meter base/socket types

Voltage	Wires	Service Capacity Amp	No. of Terminals	Meter Socket Config.*	Manual Block Bypass Required?	Accessible Disconnect Ahead & Safety Socket Required?	Socket
<b>Single-Phase Nonresidential</b>							
120/240	3	up to 200	4	A	Yes	No	Self-contained socket
120/240	3	201 to 320	4	A	Yes	No	Self-contained 320 A socket
120/240	3	above 320	6	B	n/a	n/a	Instrument transformer rated with provision for test switch
120/208	3	up to 200	5	C	Yes	No	Preferred arrangement
120/240	3	up to 200	5	C	Yes	Safety socket allowed but not required	Streetlight applications only
240/480	3	up to 200	5	C	Yes	Yes - fused disconnect preferred	Streetlight applications only
<b>All Three-Phase</b>							
120/208	4	up to 200	7	D	Yes	No	Self-contained socket
120/208	4	above 200	13	E	n/a	n/a	Instrument transformer rated with provision for test switch
120/240	4	up to 200	7	D	Yes	No	Self-contained socket (RESTRICTED APPLICATION) — High leg on right terminals
120/240	4	above 200	13	E	n/a	n/a	Instrument transformer rated with provision for test switch (RESTRICTED APPLICATION)
277/480	4	up to 200	7	D	Yes	Yes - fused disconnect preferred	Self-contained safety socket
277/480	4	above 200	13	E	n/a	n/a	Instrument transformer rated with provision for test switch

\* Meter Base/Socket Configurations



## Section 3: Current transformer (CT) metering requirements (up to 800 A)

---

Single-phase services: over 400 A and three-phase services: over 200 A

---

### Puget Sound Energy's installation responsibilities

PSE is responsible to provide and install:

- Instrument transformers
- Meters and test switches
- Metering circuits (wiring)

### Customer's installation responsibilities

Provisions for current transformers shall be made when the current-carrying capacity of the service entrance conductors exceeds 400 A single-phase or 200 A three-phase, as determined by the NEC.

#### Meter base/ socket

You are responsible to provide and install the meter base/socket.

#### Sequencing

All CT rated services shall have the meter ahead of any disconnect switches.

#### Metering circuit conduit

You are responsible to provide and install the metering circuit conduit. Metallic conduit (EMT or Rigid) or Schedule 80 PVC conduit is required between the meter base/socket and CT enclosure.

- The conduit shall be sized as follows:
  - » Single-phase: 1 inch minimum
  - » Three-phase: 1-1/4 inches minimum
- Conduit shall be as short as possible and shall not exceed 50 feet in length or 360 degrees in bends.
- A pull string is required in any meter conduit over 25 feet.
- When metallic conduit (EMT or Rigid) is used, grounding bushings shall be used at both ends.
- Conduit shall run from the CT enclosure and enter the test switch portion of the meter base/socket.

**NOTE:** Metering circuit conduit shall not contain LB joints, condulets, junction boxes, or flex conduit. The preferred method of installing conduits entering the CT enclosure is shown in Figure 29.

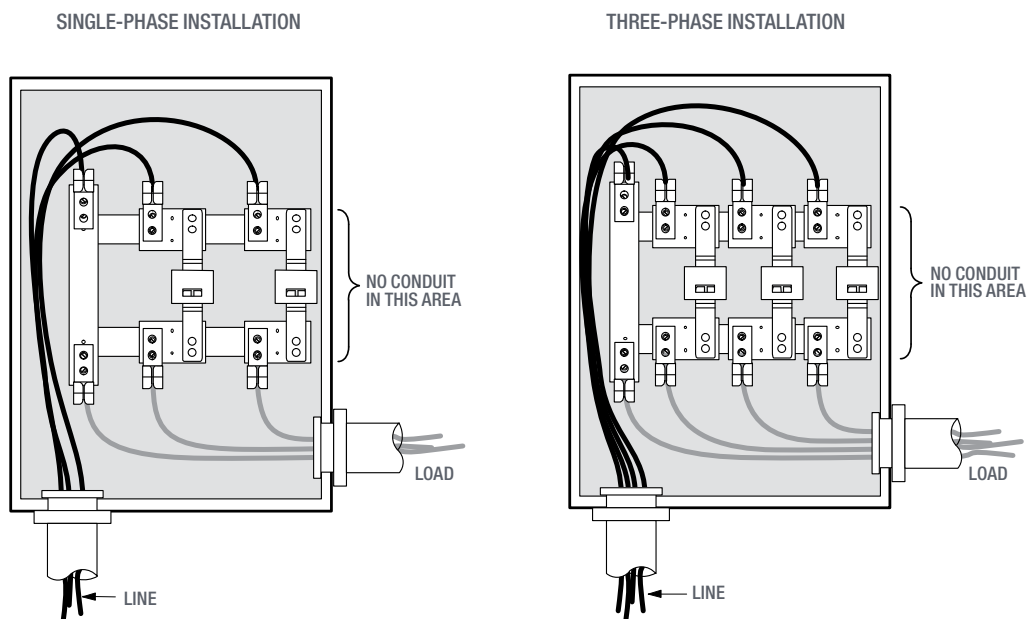
#### Approval drawings required

Manufacturers drawings shall be submitted for all CT enclosures prior to shipment from the manufacturer. One set of drawings shall be sent directly to PSE's Meter Engineering for their required approval.

#### Location requirements

CT enclosures must be located in non-traffic areas where PSE Meter Journeymen can work safely. Additional location requirements are found in this chapter.

**Figure 30** Preferred method of conduit installation in a single-phase and three-phase CT enclosure



### CT enclosure

You are responsible to provide and install a CT enclosure (see Table 9) ahead of the main disconnect on the outside of the structure, or in an approved electrical room (see Electrical room requirements section of this chapter).

- Enclosures shall not be mounted in crawl spaces, attics, any confined areas, or mounted on ceilings.
- The CT enclosures require a minimum front clearance of 36 inches.
- Hinged CT enclosure doors shall not block a safe exit while open.
- The top of the CT enclosure shall be a maximum of 8 feet above the floor or finished grade; the bottom shall be a minimum of 6 inches above the floor/grade.
- The CT enclosure shall not be used as a junction box or bus gutter.
- The CT enclosure covers shall not open vertically. Covers shall open horizontally, right to left, or double hinged on right and left (split door).
- The CT enclosure must be the NEMA 3R outdoor type.
- The CT enclosure requires a side wall clearance or other obstruction clearance of 2 inches.
- The CT enclosure must be lockable by PSE with standard PSE locking and sealing devices.

**Table 9** CT enclosure dimensions (minimum)

Phase	Switch Ampacity	No. of Transformers	Width	Height	Depth
1 *	401-800	2	24"	48"	11"
3 *	201-800	3	36"	48"	11"
3 **	Over 800	3	**	—	—

\* Enclosure with a side-opening single-hinged door is required when cabinet dimensions are greater than 24" x 48".

\*\* Services over 800 A require a switchboard designed to EUSERC specifications. Refer to the Remote Metering section in this chapter for more information. Services from 201-800 A may be switchboard designed to EUSERC specifications. Drawing must be submitted to PSE's Meter Engineering.

### Mounting the CT

You are responsible to do the following:

- Install a CT mounting base on services of 800 A or less (see Figures 30 and 31).
- Provide and install two bolt lugs on the line and load sides of each phase and the neutral bus.

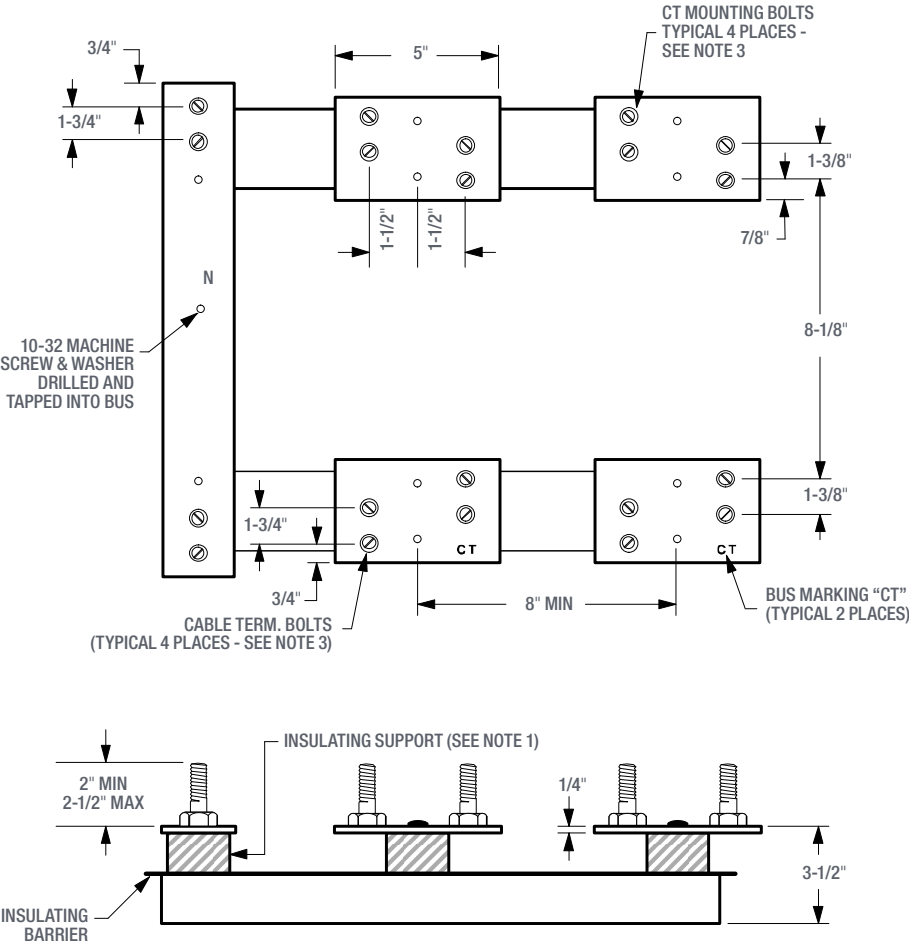
**NOTE:** An instrument transformer enclosure shall contain only the main service conductors. Two types of current transformer brackets are available for terminating main service conductors: bolted lug and molded connector type.

- Bolted current transformer mounting brackets allow two main service conductor connections per current transformer bracket. Current transformer brackets with molded connector blocks allow up to:
  - » Three main service conductor connections per bracket when individual connector blocks are used.
  - » Six main service conductor connections per bracket when stackable connector blocks are used.

A gutter or junction box is required if there are more than six main service conductors.

- All new CT brackets or rebuilt CT enclosures shall be 50 kA fault current rated.

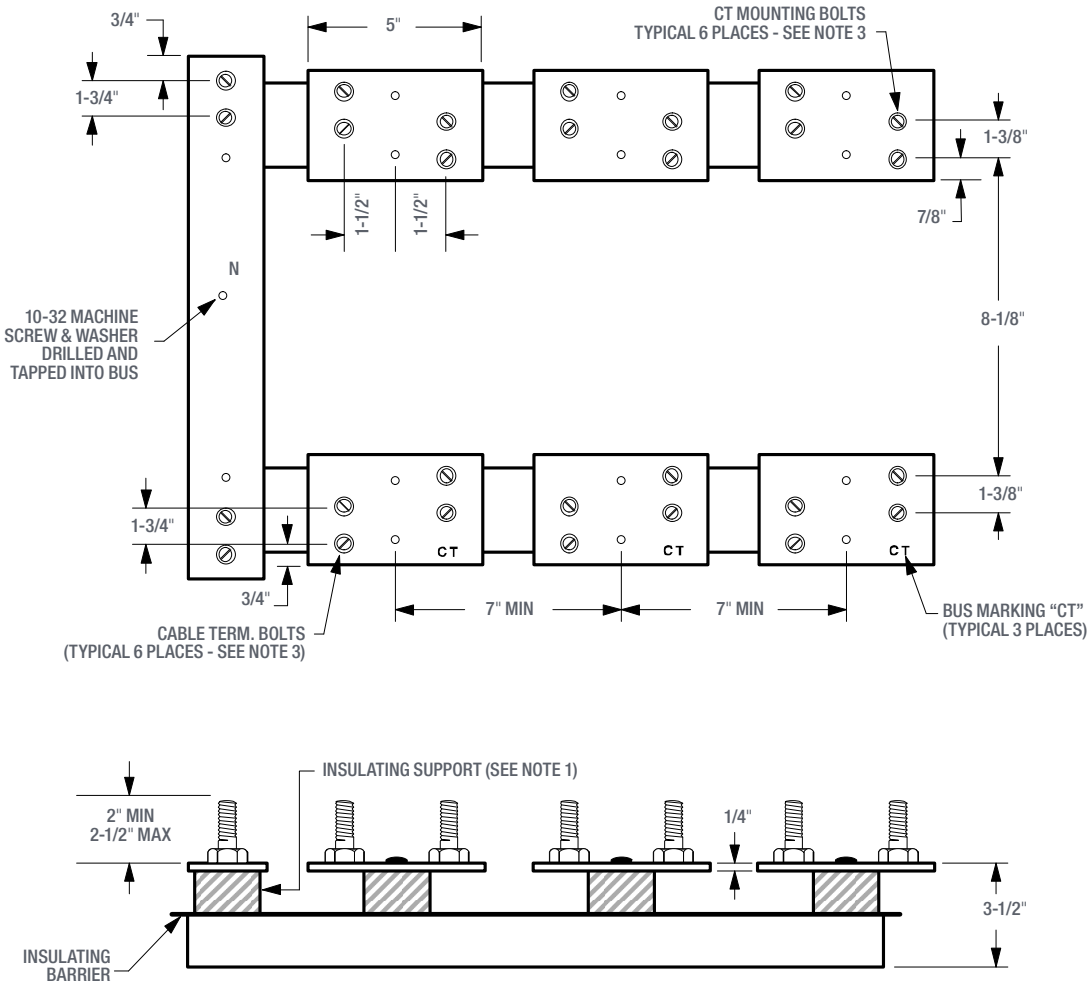
Figure 31 Single-phase CT mounting base bracket. EUSERC 328A (shown) or 328B



NOTES:

1. Insulated supports shall be rated for the serving voltage and have sufficient mechanical strength for the application.
2. Mounting base accepts bar-type current transformers only.
3. Two 1/2 inch steel bolts shall be provided for each cable terminating position and each bolt shall be furnished with a spring washer and a nut. The spring washer may be either a cone-type (belleville) or a split-ring washer and a flat washer. Bolts shall be secured in place and spaced as shown. All parts shall be plated to prevent corrosion.

Figure 32 Three-phase CT mounting base bracket. EUSERC 329A (shown) or 329B



**NOTES:**

- 1. Insulated supports shall be rated for the serving voltage and have sufficient mechanical strength for the application.
- 2. Mounting base accepts bar-type current transformers only.
- 3. Two 1/2 in. steel bolts shall be provided for each cable terminating position and each bolt shall be furnished with a spring washer and a nut. The spring washer may be either a cone-type (belleville) or a split-ring washer and a flat washer. Bolts shall be secured in place and spaced as shown. All parts shall be plated to prevent corrosion.

### Customer requirements for switchboard metering (over 800 A)

A custom-built switchboard constructed to Equipment Utility Service Requirements Committee (EUSERC) specifications is required for services over 800 A. Switchboard metering may be used on services from 201-800 A, at your discretion.

**Approval drawings required**

Approval drawings shall be submitted for all switchboard metering prior to shipment from the manufacturer. One set of drawings shall be sent directly to the PSE Meter Engineering for their required approval.

**Installing current transformers**

PSE will supply the CTs to be installed by your electrician in the CT section of your switchboard for services larger than 800 A. Coordinate with your Project Manager to arrange for delivery of the CTs.

**Three-phase services**

Three-phase services require 13-terminal meter bases/sockets mounted on the switchboard according to EUSERC 332 (see Figure 34, Diagram B), or mounted remotely and connected with approved conduit. The conduit shall terminate in the CT compartment and the test switch portion of the meter base/socket (see Figure 34). The conduit shall terminate on the front one third, hinged side, of the CT compartment.

Figure 33 Options for switchboard meters

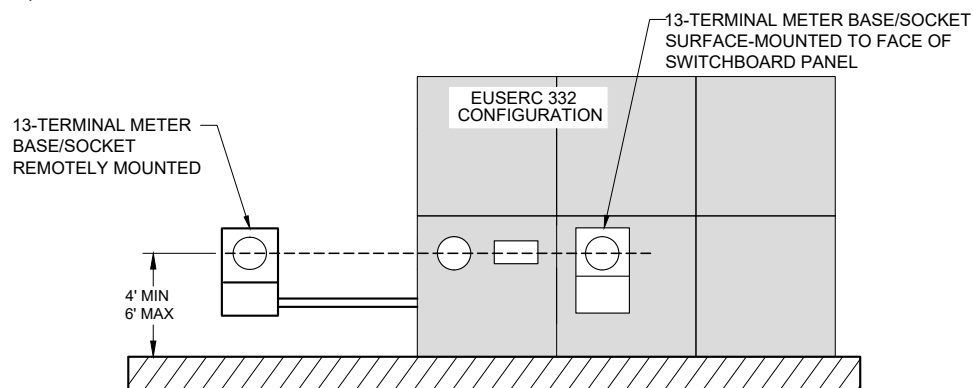
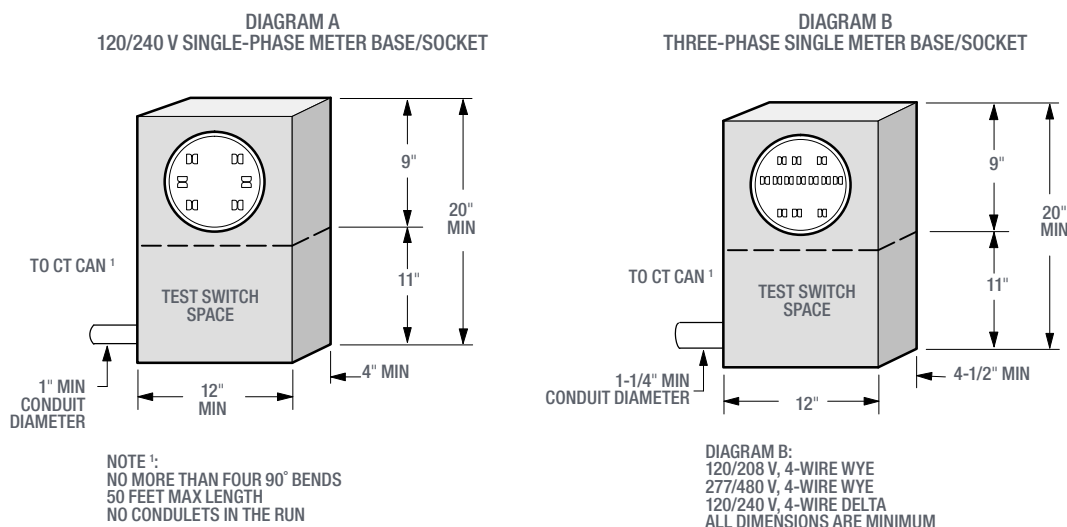


Figure 34 Instrument-rated CT meter bases/sockets



## Section 4: Primary metering requirements

---

### 4.16 kV, 12.47 kV and 34.5 kV (200 A and 600 A)

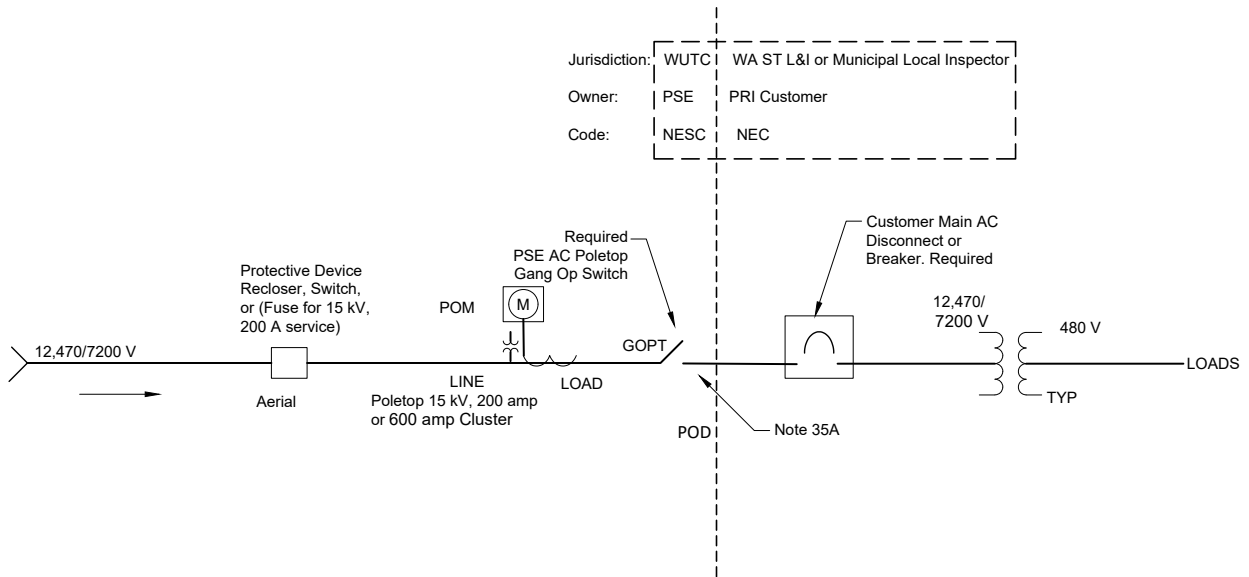
---

#### Customer's responsibilities

	The customer is responsible for the installation, operation, maintenance, and repair of their system beyond the Point of Delivery (Interconnection). See Figures 35A, 35B, and 35C.
<b>Location requirements</b>	<p>The primary meter must be in a location that can be accessed by a line truck and accessible 24/7 by PSE.</p> <p>Overhead primary metering shall be installed on a PSE-installed, owned, and maintained pole.</p>
<b>Data requirements</b>	<p>The customer is to provide PSE with the following information:</p> <ul style="list-style-type: none"> <li>• A complete one-line electrical diagram of the customer's primary voltage system, including updates to this diagram as design changes occur.</li> <li>• Complete protective relay or fuse data concerning the main breaker or main fused disconnect point.</li> <li>• A list of customer-owned transformers, including their size, number, impedance, grounding, and connection data.</li> <li>• Motor schedule, including the size, number, operating voltage, grounding, and connection data.</li> <li>• Detailed information about any customer-owned generation that is intended to be operated in parallel with PSE's electrical grid. Customer-owned interconnection protection is required. Contact the System Protection group for the necessary requirements.</li> <li>• A description of energy-intensive equipment that can cause voltage flicker, such as X-ray machines, stamping mills, electric welders, and arc furnaces.</li> </ul>
<b>Equipment requirements</b>	<p>In addition to the equipment beyond the Point of Interconnection (POI), the customer is responsible for the following equipment and installation costs. Refer to Figures 35A, 35B, and 35C.</p> <ul style="list-style-type: none"> <li>• Pole-top metering cluster for overhead services.</li> <li>• Primary metering cabinet (PMC) for underground services.</li> <li>• Pole-top gang operated switch (GOPT) for overhead services.</li> <li>• PSE ac disconnect padmount for underground services.</li> <li>• Protective device: recloser, switch, or fuse for aerial or underground residential distribution (URD).</li> </ul>
<b>Existing customer</b>	<p>When an existing primary metered customer is modifying their system by adding or removing equipment, they must configure their primary electrical system to meet the current PSE standards requirement. This would require installing an isolating device on their system. In a 600 amp primary system, this will require installing a padmounted ac disconnect switch (see Figure 35C). Emergency repair or like for like replacement does not constitute modifying of the system.</p> <p>Primary metered customers who have experienced a failed primary underground cable must have their underground system tested after repairs have been made. Test results must suggest their primary underground system is in good operating condition. The findings of this testing are to be provided to PSE before PSE will energize their system.</p>

**Figure 35** Electric primary voltage Schedules 26 and 31 circuit diagrams

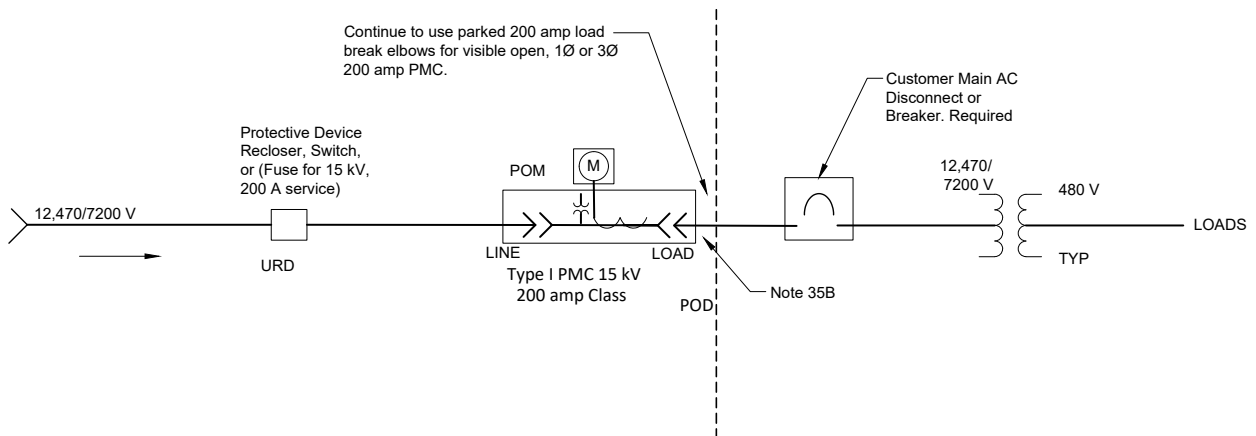
**Figure 35A** Pole-top 15 kV, 200 or 600 amp cluster (overhead installation)



**NOTE 35A**

PSE’s contractor, Potelco, will install the PSE switch pole, gang-operated switches, and all six jumper wires, as well as terminate the customer’s wires on the PSE switch pole deadend crossarms.

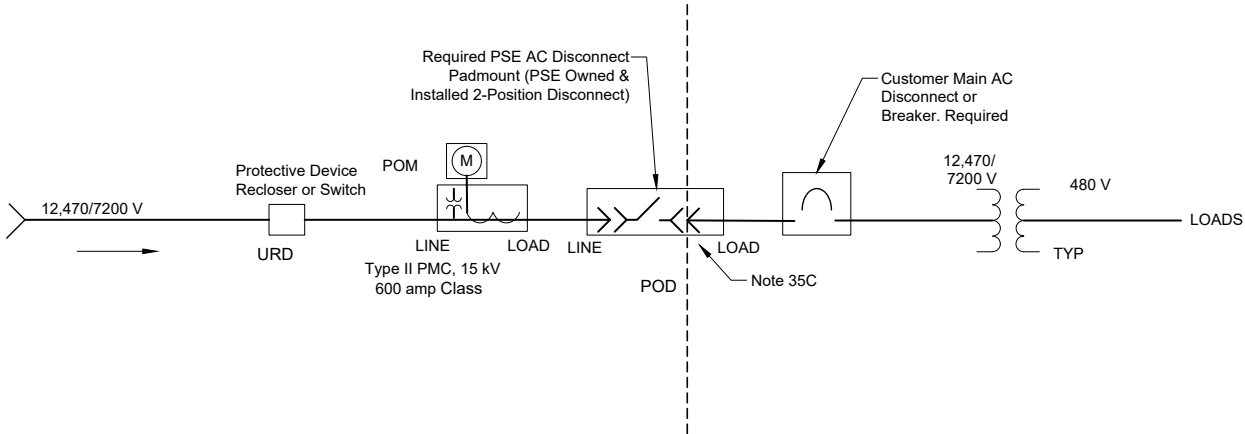
**Figure 35B** Type I PMC 15 kV, 200 amp class (underground installation)



**NOTE 35B**

Customer-owned, installed, and maintained facilities include wire and terminations (elbows) on the load side of PSE’s PMC. The customer is to land wire on the load side of PSE’s PMC.

Figure 35C Type II PMC, 15 kV, 600 amp class (underground installation)



**NOTE 35C**

Customer-owned, installed, and maintained facilities include wire and terminations (elbows) on the load side of the PSE ac disconnect. The customer is to land wire on the load side of the PSE ac disconnect.

The customer will be permitted to install a private lock and be granted access to the customer compartment (load side) of the PSE-installed ac disconnect switch. The customer shall not operate the load side of the of the PSE-installed ac disconnect switch to either pick up or drop load. All dropping or pickup of load by the customer shall be done at the customer-installed ac disconnect switch.

# Chapter 5

## Customer generation

---

This chapter provides PSE's requirements to interconnect and operate customer-owned and installed generation sources in parallel with PSE's electric distribution system. Customer generation sources include fuel cell, hydroelectric, biomass, solar, battery, or wind power generators.

---

### Responsibilities

**Puget Sound Energy** PSE will review all interconnection applications, and once approved, will issue Approval to Construct. Once the customer has completed the installation, passed the NEC inspection and provided the Notice of Completion to PSE, PSE will commission the system, install meters as applicable, and issue the Approval to Energize (also known as Permission to Operate).

**Customer** The customer shall submit an application to interconnect ahead of constructing/ installing a customer-generation system. This includes any system that will interconnect with and operate in parallel with PSE's electric distribution system regardless of the intent to export energy onto PSE's system. Customers shall also submit an application to modify an interconnected system prior to making material changes to an existing system. Failure to obtain approval ahead of construction may result in delays and unanticipated costs for any corrections necessary. All customer electrical equipment must comply with the NEC and any state or local code requirements.

After installation is complete and has passed the NEC inspection, the customer shall submit the Notice of Completion to PSE. The customer will then be given Approval to Energize (also known as Permission to Operate) the system, in most cases, once PSE personnel visit and inspect the generation equipment.

---

## General requirements

Customer generation systems may be connected to and operate in parallel to PSE's facilities in accordance with Electric Tariff G, Schedule 152. The provisions of Schedule 152 apply to all Interconnections, including without limitation Net Metering Interconnections (renewable generating systems up to 100 kW ac), eligible for special considerations outlined in Schedule 150.

Additional information about PSE products, services, and rates available for customer generating systems can be found at:

- [pse.com/netmetering](https://pse.com/netmetering) (for solar, solar plus batteries, and other renewables up to 100 kW ac)
- [pse.com/distributedrenewables](https://pse.com/distributedrenewables) (systems outside of Net Metering)

The design of these systems shall meet PSE's standards for voltage flicker and harmonics and will be served by PSE at a standard service voltage (see Chapter 1, Table 1).

---

## How to apply for interconnection

Customers must submit a signed Interconnection Application (including system diagram) using PowerClerk, our online application portal.

To apply for interconnection of a net metered system (including solar and solar plus battery systems up to 100 kW ac), visit <https://psenetmetering.powerclerk.com>.

To apply for interconnection of batteries that are not paired with solar (or other systems that do not qualify as net metered), please visit <https://psedistributedgenerationinterconnections.powerclerk.com>.

---

## Interconnection system diagrams

For PSE to review the interconnection application, a one-line diagram and site plan must be included. The one-line diagram shall note equipment model numbers, power output capacity, and site address. The diagram shall schematically represent all relevant equipment from the generator through to PSE's electric distribution system, and the site plan shall provide a birds-eye view of the relative locations of this equipment including:

- Generator(s) such as solar modules
- Inverter(s)
- Battery bank (as applicable)
- All disconnect switches, including any PSE-required disconnect switch labeled as a visible/lockable break (as applicable)
- Combiner panels (as applicable)
- Sub panels, including critical loads panels (as applicable)
- Gateways, transfer switches (as applicable)
- Main electrical panel
- Specific point of interconnection (designated breaker or location of line side tap)
- Conductor schedule
- Equipment schedule
- Production meter (as applicable)
- Service meter (net meter)
- Switch gear specifications (as applicable)

For modifications to existing interconnected systems, the diagram must include the existing and newly proposed elements of the system, as they will operate together.

PSE prefers the one-line diagram to be on a single page when possible.

A system diagram guide can be found at [pse.com/netmetering](https://pse.com/netmetering).

---

## Meter location

Net meters and production meters are subject to the meter location requirements defined in Chapter 4 of this handbook.

Production meters are optional. When a production meter is requested, it must be shown on the system diagram and noted on the Interconnection Application. A **single** production meter must be able to accurately measure all and only energy produced by the generating system and must be located adjacent to the net meter.

“Adjacent” is defined as between 10 inches to 6 feet center-to-center along the same wall. Installers shall not round corners.

Production metering for an expansion of a Generating Facility (defined as all generation behind a single net meter) will be reviewed on a case-by-case basis. The priority is for “all or none” of a generating facility’s energy output to be measured.

More information about why a customer may want production meters can be found at [pse.com/netmetering](https://pse.com/netmetering).

---

## Meter socket requirements

When an optional production meter is requested, the customer shall provide and install the meter socket. Customer-provided metering equipment shall meet the requirements stated in Chapter 4 of this handbook. Production meter sockets shall not be “jumped” prior to PSE’s installation of the meter.

Customers may not tap at or in a meter socket.

---

## Labeling and signage requirements

The labeling requirements in Chapter 4 of this handbook apply to net and production metering enclosures. In addition to those requirements, meter enclosures shall be labeled with permanently affixed signage at the production meter and net meter enclosures to identify their function (i.e., "NET METER" or "PRODUCTION METER"). Where a customer generation source includes a battery that operates in parallel with the grid, whether in combination with other generation sources or as a stand-alone battery, an additional permanently affixed label that reads "BATTERY" in red color must be affixed to the meter base. Where metering is accomplished at different voltages, the signage must also identify the voltages at which the meters are energized.

**Multiple Disconnect Locations:** Where a generating system utilizes more than one disconnect point to meet PSE’s disconnect switch requirement (detailed below), phenolic labels must specify which numbered disconnect is being referenced (e.g., "DISCONNECT 1 OF 2" and "DISCONNECT 2 OF 2"). In addition to labeling each disconnect that is a part of meeting PSE’s disconnect switch requirement, if disconnects are not colocated with the meter, the customer must provide a directory at the service meter indicating where the disconnect(s) are located and vice versa.

Labels shall conform to the requirements of NEC Article 690. All labeling should be capitalized. PSE requires engraved phenolic nameplates or adhesive die-cut labels at least 1 inch high, with raised or cut-out lettering that is a minimum of 3/4 inch high.

---

## Disconnect switch requirements

PSE must have the ability to disconnect customer generation from PSE's system for employee protection. In many cases, PSE will pull and lock out the service meter to isolate the customer with an interconnected generating system from the grid during a PSE system outage. However, this is not safe or possible in all situations, and a visible lockable air gap may be required.

A visible air gap, lockable disconnect switch is required in any of the following scenarios:

- Maximum generation capacity of combined generation sources, including batteries, is greater than 25 kW ac.
- Electric service is three-phase.
- Electric service is CT-metered.

When a visible air gap, lockable disconnect switch is required, it must be a single switch that isolates the entire generating system and be colocated with the electric service (net) meter.

An exception is allowed in the following circumstances:

- When a single required visible, lockable disconnect switch is accessible, but is not colocated with the electric service (net) meter, labeling must provide a directory at the service meter indicating where the disconnect is located and vice versa.
- When 2 or more generating sources (separate PV arrays, PV and batteries, etc.) are interconnected at different points (different breakers, subpanels, etc.), multiple disconnect switches may be used with proper labeling (see labeling requirements in previous section).
- When a PSE disconnect switch is required for PV plus batteries because generation capacity is greater than 25 kW ac on single phase service, no greater than 400 amps and has a self-contained 2S meter, Disconnect 1 of 2 may isolate a portion of the generating capacity that when in the off position, brings the total capacity down to below 25 kW ac and Disconnect 2 of 2 is the service meter pull. Labeling to clarify this sequencing is required.

When the generation system includes optional production metering, the disconnect switch shall be connected to the load side of the production meter (between the production meter and electrical panel) in case of 480 V self-contained production meters.

---

## Commissioning

Commissioning by PSE is to ensure that the customer generating system was installed according to PSE standards and the approved plans. In most cases, PSE will conduct an on-site inspection, including testing and the installation of meters as applicable.

Unless otherwise noted, the customer must leave the customer generation system off until PSE commissions the system, conducts testing as applicable, and issues the Approval to Energize (also known as Permission to Operate).

- **Net Metered Solar System without Batteries, with an accessible ac disconnect switch:**  
The system must be left off at the accessible ac disconnect switch after the NEC inspection until PSE commissioning and the Approval to Energize. The system is expected to turn on for testing when PSE puts the disconnect switch in the on position.
- Net Metered Systems that include optional production metering shall be left on at the disconnect switch with the PSE production meter socket covered and empty. The system is expected to turn on for testing when PSE installs the production meter.
- **Net Metered Solar System without batteries, without an accessible ac disconnect switch, or one that cannot be left in the off position (whole home disconnect switch):**  
The system must be left off at the breaker after the NEC inspection and the customer/installer should indicate on their Notice of Completion that an appointment is needed for PSE commissioning.
- Modification to an existing interconnected solar system that requires an added disconnect switch should follow the same guidelines as for other Net Metered Solar Systems above.

### Noted Exceptions

- Residential battery-only systems shall be left on after the NEC inspection and submittal of the Notice of Completion to PSE.
- Net Metered Systems with solar and batteries should be left on and in full export mode after the NEC inspection, once PSE has received the Notice of Completion, completed the desktop review, and notified the customer that a commissioning site visit is the next step. This ensures that the batteries will be charged, enabling PSE to conduct interconnection testing upon arrival.
- Modifications to existing interconnected solar systems without batteries that do not require a new utility disconnect may be left on after the NEC inspection and the Notice of Completion has been submitted to PSE.

PSE maintains the right to conduct an inspection to verify compliance with its guidance at a later date if problems arise or indications of possible noncompliance to NEC Article 720 or the applicable PSE guidance documentation are present.

---

## Testing

During system commissioning, or at any point to address interconnection safety concerns, PSE may test the customer generating system.

During a loss of grid ac input or a such simulated testing:

- The available dc voltage present at the solar interconnection point or utility point of connection (POC) shall be no more than 30 Vdc or 15 Vac within 30 seconds of rapid shutdown initiation. If a dc voltage is constant and measurable, it shall measure below 30 Vdc or 15 Vac between any two conductors or any conductor and ground.

Refer to NEC Article 690.12, Rapid Shutdown of PV Systems on Buildings, and UL 1741, Standard for Inverters, Converters, Controllers and Interconnection System Equipment for Use with Distributed Energy Resources, for more details.

- The available dc current present shall be limited to 0.5% of the reference of interconnection per IEEE 1547, Section 7.1, Limitation of DC Injection of 0.5% of Reference Point of Interconnection.

(That translates to 200 amps x 0.5% = 1 amp dc limit for a CL200 net meter point of reference.)

---

## Resources

Additional information about interconnection and net metering with PSE (including Rate Schedules 150 and 152, and system diagram guides) can be found at [pse.com/netmetering](https://pse.com/netmetering).

When a standards variance is requested, it must be submitted for PSE review and approval prior to system construction. Submit variance requests to [netmetering@pse.com](mailto:netmetering@pse.com) for net metering projects or [distributedrenewables@pse.com](mailto:distributedrenewables@pse.com) for all other customer generation projects.

Technical interconnection and interoperability requirements for distributed energy resources >100 kW or not qualified as Net Metered systems can be found [here](#).

# Chapter 6

## Temporary services

---

### What this chapter contains

In this chapter you will find answers to questions such as:

- What are the installation requirements for underground and overhead service?
- What are the trenching requirements?
- How do I locate existing underground utilities before I dig?
- How do I get my temporary service energized?

### Three-phase temporary service

If you require three-phase temporary service, your Project Manager will contact PSE's Meter Department.

---

## Definition

A temporary (temp) service is a means of supplying electricity to your site for less than one year. Typically, a temp service provides power for the construction phase of your project, while provisions are being made for your permanent power system. Temp service is provided underground or overhead depending on available PSE facilities.

---

## Obtaining your temporary service from existing power facilities

The following information applies to your temp service installation:

- Determine if you need overhead or underground service.
- Obtain an electrical work permit.
- Order underground utility locate service by contacting the 811 "Call Before You Dig" hotline minimum two business days before digging.
- Prepare the job site and install your temp service equipment (service post, pedestal, and meter base).
- Obtain an electrical inspection approval of your temp service equipment (this is done by you or your contractor).
- Call PSE to request that your temp service be connected and energized after your electrical inspection is complete.
- Apply for permanent service.
- At your request, we will check your site to determine if engineering is required.

If you have any questions, please call Customer Construction Services (CCS) at **1-888-321-7779**

---

## Scheduling

Most temp services are connected to existing power facilities and engineering is not required. In these cases temp services are typically energized 3 to 5 days after your installation has passed inspection. Depending on complexity and work volume, time frames will vary.

---

## Customer charge for service

Charges vary due to the type of system we have in your area. Your CCS Representative will explain current temp service fees.

---

## Temporary meter base/socket requirements

You are required to provide a meter socket with the following specifications:

- A ring-type socket that includes a screw-type, stainless steel, or aluminum meter ring (snap-type rings must be stainless steel).
- Rated 120/240 V
- Single-phase
- Minimum rating of 100 A
- Maximum rating of 200 A
- Four jaws
- Underwriters Laboratory (UL) approved

**NOTE:** A 120/208 V single-phase service requires a 5-terminal meter base with the fifth terminal tied to the neutral bus conductor. A 277/480 V three-phase service requires an accessible disconnect ahead of each meter socket and a safety socket with a manual bypass.

If you would like a service of 201 A or greater, refer to the metering requirements in Chapter 4, Meter Installation, located in this handbook.

All conductors necessary for standard service voltage, provided in Chapter 1, Table 1, must be determined.

---

## Temporary underground services

Temp underground service is available in PSE's service area where the existing power facilities are installed underground.

The process and cost of obtaining your temp underground service can vary, depending on the location of our existing facilities. If there is a power stubout, handhole, pedestal, or transformer located on your property, engineering may not be required. Simply install your temp service facilities (see Figure 36 and Figure 37), obtain an electrical inspection, and call PSE to connect your temp service.

**Meter location**

To properly locate your temp meter pedestal, set the meter pedestal on your property no more than 5 feet from the transformer, stubout, handhole, or pedestal.

If a distance greater than 5 feet is required, please contact a CCS Representative for approval prior to construction.

**Trenching and excavation requirements**

It is the customer's responsibility to provide the trenching needed to connect to a power stubout (shown in Figure 36). The cable you provide is to be sized according to the NEC and have a minimum 24 inches of backfill coverage.

**NOTE:** A 4-foot-square excavation is required at the stubout to provide working room for our personnel to splice your cable to ours.

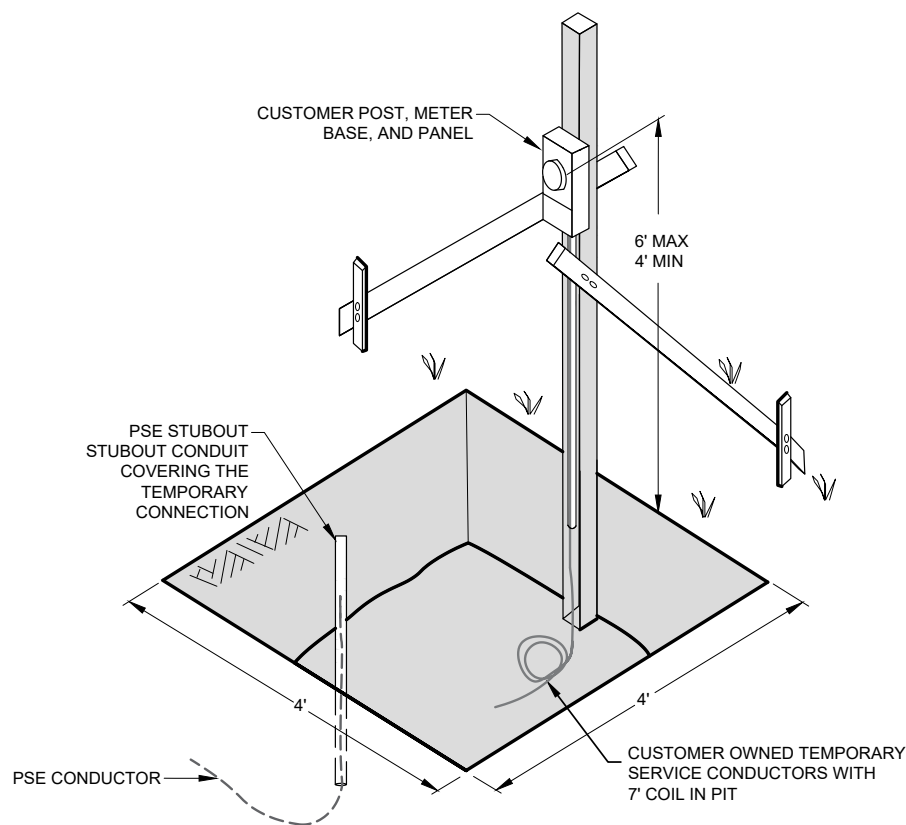
If the connection point to PSE facilities is a handhole, pedestal, or transformer; trench up to the nearest side and leave your wires exposed. If you discover any other conductors while digging your trench, please leave them covered. If further trenching is required, our personnel will complete it.

Remember to order underground utility locate service by contacting the 811 "Call Before You Dig" hotline minimum two business days before digging.

**NOTE:** Any trenching within 24 inches of existing underground facilities must be done by hand.

**Figure 36**

Trenching requirements for power stubout



**NOTE:** 4' x 4' work pit required to allow working room for the tools necessary to connect temporary service.

**Underground  
temporary  
service  
installation  
process**

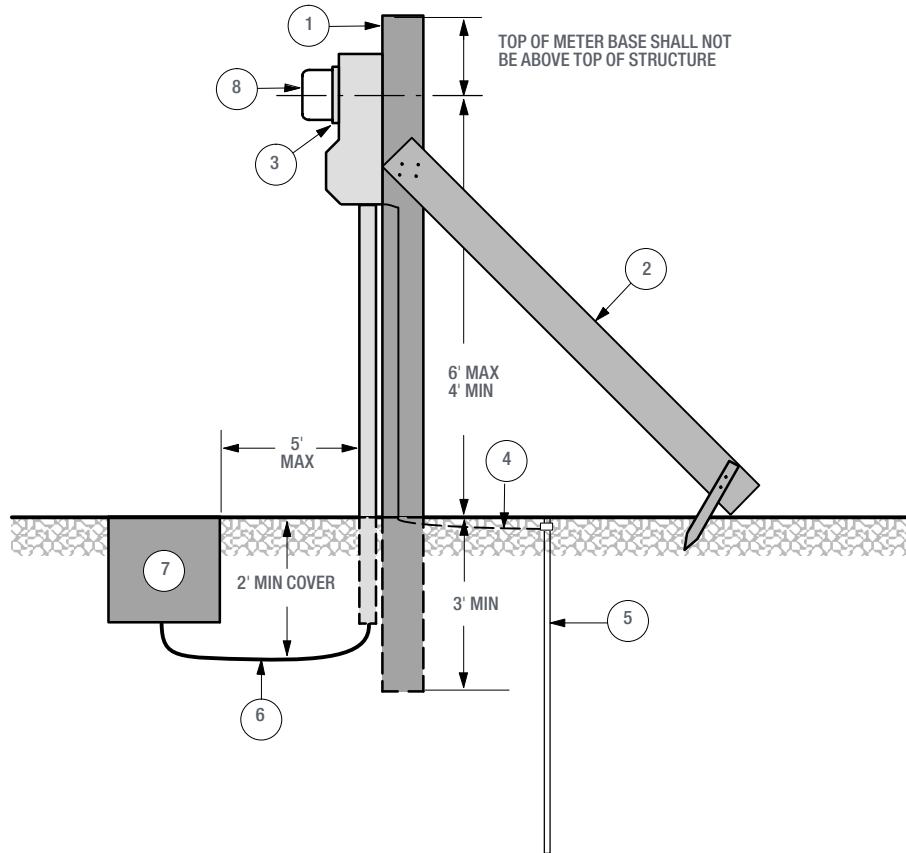
The following items must be completed before energizing your underground temp service:

1. Contact a CCS Representative at **1-888-321-7779**, and request your temp underground service.
2. Obtain an electrical work permit from the inspecting agency.
3. Order underground utility locate service by contacting the 811 “Call Before You Dig” hotline two business days before digging.
4. Install your meter pedestal and meter base/socket in the appropriate location (see Figures 34 and 36).
5. Provide the appropriately sized conductor from your meter socket to PSE’s connection point. Please leave 5 feet of extra cable at the stubout or handhole, and 10 extra feet at a transformer. Consult the NEC for the appropriate cable sizes.
6. Obtain and pass an electrical inspection.
7. Trench up to and expose the PSE connection point at the stubout, handhole, or transformer.
8. If trenching is provided, cover your cable except in the work pit where our personnel will be splicing your cable to ours.
9. After the above items are complete, call CCS at **1-888-321-7779** and inform a CCS Representative that your installation has been inspected and that you are ready for your temp service.

This installation shows a safe temp service. Do not deviate from the installation standards without approval from your CCS Representative. Doing so may extend the time frame for your service hookup.

If service needs to be connected in right-of-way (ROW), a permit will be required. This can take several weeks.

Figure 37 Temporary underground service installation



Items owned and installed by customer	
1	4" x 4" x 10' continuous single structure
2	2" x 4" bracing (post should be braced from two directions)
3	Meter socket and distribution panel (up to 200 A, 120/240 V)
4	Ground wire, in accordance with NEC/WAC
5	Ground rod, in accordance with NEC/WAC
6	Service entrance conductors in accordance with NEC

Items owned and installed by PSE	
7	Transformer, handhole, pedestal, or stubout
8	Meter

**NOTE:** Trench and backfill from meter base to transformer, handhole, pedestal, or stubout is customer provided.

---

## Temporary overhead services

Temp overhead service is available anywhere in PSE's service area where the existing electrical system is installed overhead.

The process and cost of obtaining your temp overhead service can vary depending on the location of our existing facilities. The least complicated and cheapest way a temp service can be installed is if a transformer is located on a pole alongside your property. If this is the case, engineering may not be required. All you have to do is install your temp service equipment, have it inspected, and call Customer Construction Services (CCS) at **1-888-321-7779** to order your service. Once the above items are completed, your service will be connected within a few business days.

### Meter location

Your temp meter post should be located on your property and within 70 feet of the PSE pole that will serve you. This limitation ensures that your temp service pole can withstand the weight of the conductor. If a distance greater than 70 feet is required, or if PSE's pole is on the opposite side of the street, please call CCS for approval prior to construction. A taller, stouter post with additional bracing could be required.

### Service line path requirements

In addition to the meter post distance limitation mentioned above, the service line path requirements are:

- The path that the service line will take should not cross property belonging to other individuals.
- If the service line will pass through trees or brush, clear a path to allow our service personnel to run the line and to allow the lines to hang without contacting trees or limbs. Maintaining this clear path is the customer's responsibility.
- The service line path should avoid areas where vehicular traffic will occur, unless your temp service post height is increased to provide adequate clearance (see Figure 38).

### Clearance requirements

The National Electric Code (NEC) and the National Electric Safety Code (NESC) have established minimum clearance requirements to maintain safe heights for electrical conductors over various terrains.

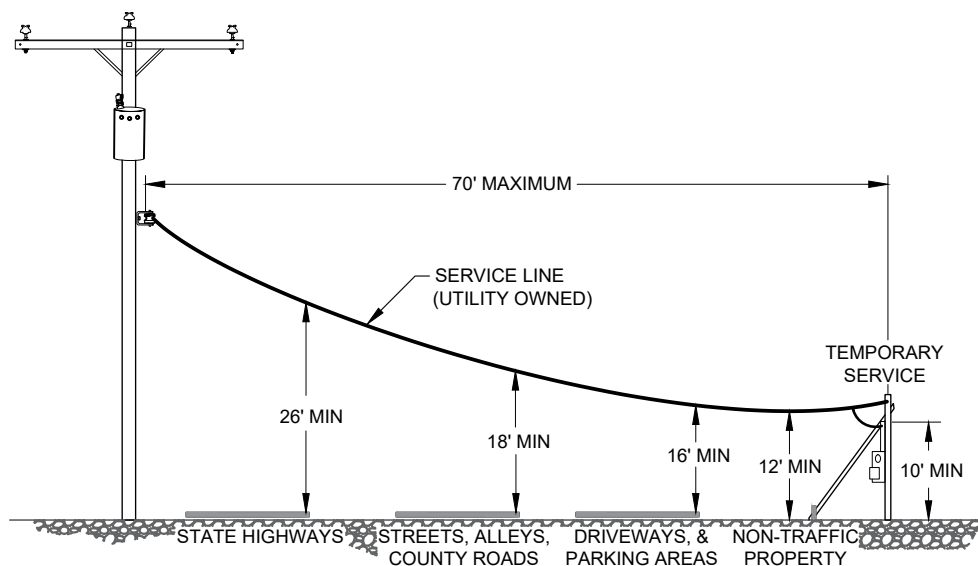
Figure 38 shows the clearance requirements for the types of terrain most commonly encountered.

The NEC and NESC require the lowest point of a service conductor to be at least 12 feet aboveground. The bottom of the drip loop must be a minimum of 10 feet above the ground.

You are required to provide a point of attachment on your service pole that will allow PSE to install the conductor and maintain the required clearances.

If you need further details, please consult the current issue of the NEC, or contact the state or local electrical inspector for your area.

**Figure 38** Minimum clearance requirements upon installation



### Overhead temporary service installation process

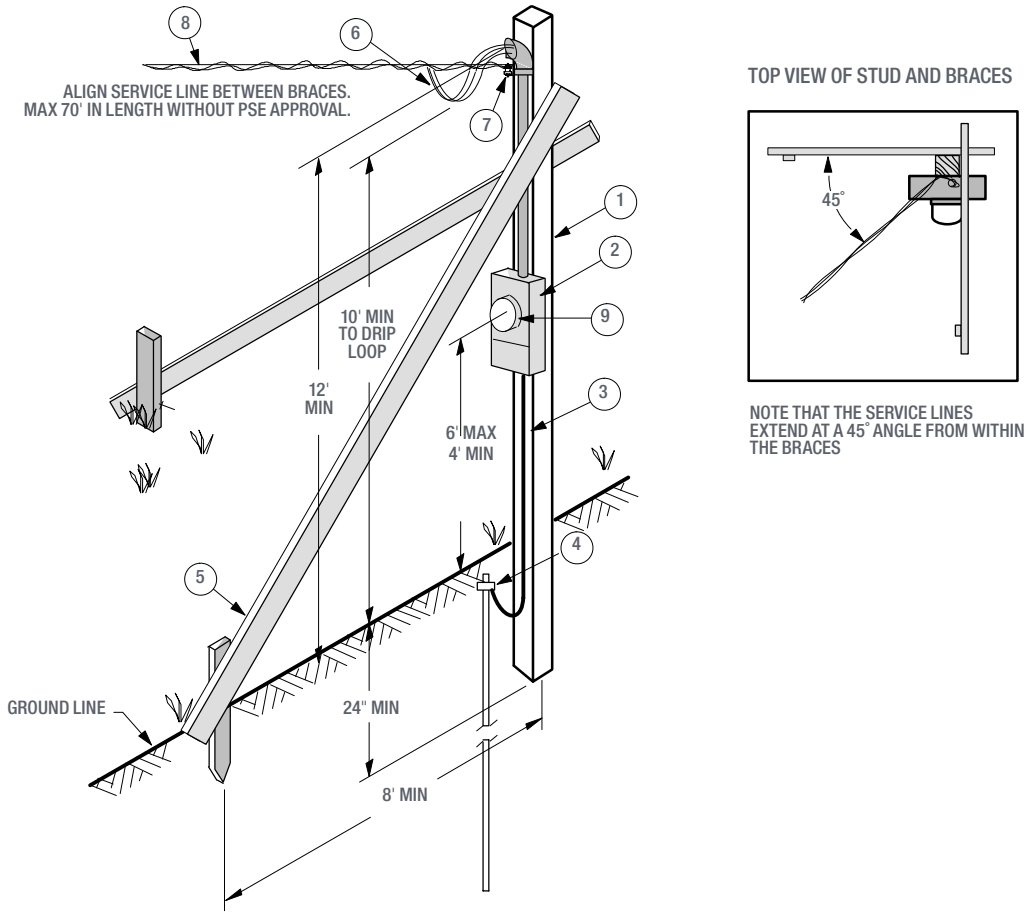
The following items must be completed before we can energize your service:

1. Contact a CCS Representative and request your temporary overhead service.
2. Obtain an electrical work permit from the inspecting agency.
3. Install a meter pole and meter socket. Temporary service equipment on trees is not acceptable.
4. Obtain and pass an electrical inspection.
5. After these items are completed, call CCS and inform a CCS Representative that your installation has been inspected and that you are ready for temp service.

Figure 39 shows a typical temp overhead service installation.

Consult with your CCS representative for non-typical installations.

Figure 39 Temporary overhead service installation



Items owned and installed by customer	
1	4" x 4" x 16' or 2" x 10" x 16' minimum, continuous single structure. No timber
2	Meter socket and distribution panel (up to 200 A, 120/240 V)
3	Ground wire, in accordance with NEC/WAC
4	Ground rod, in accordance with NEC/WAC
5	2" x 4" brace (two required)
6	Service entrance conductors - 18" out of weatherhead minimum
7	Insulated clevis (point of attachment)

Items owned and installed by PSE	
8	Service line
9	Meter

# Chapter 7

## Disconnection and modification of service

---

There may be a time when your electric service needs to be modified. You may wish to have your service disconnected, reconnected, moved from its current location, relocated, or simply de-energized. This may involve lengthening, shortening, transferring, or rerouting the existing service.

---

### Disconnection of your meter

If you need the power disconnected to work on your side of the meter, a temporary modification of PSE facilities is required to disconnect and reconnect at the power source. Disconnection and reconnection may require one or two servicemen, or a crew, to open the transformer fuse, to disconnect the service conductor from the source, or to pull the meter.

In some cases, PSE will also need to make a permanent facility modification, such as a transformer upgrade, to meet the customer's changing electrical need.

If the wire has to be removed, relocated, or otherwise manipulated as this becomes a modified service, refer to the Modified services section below. Check with your CCS Representative to verify any charges that you may incur.

---

### Non-residential modified services installing new/upgrading existing with NEC required disconnect style meter (occupied structure)

Customers making modifications to their service (including a new/upgraded meter base, an upgrade/work on the panel, and work on the CT can) will have their service disconnected to accommodate the cutover. The service shall not be reenergized until all new customer wires are landed with grounding and bonding in place. Use of the disconnect alone is not sufficient for PSE to leave the service energized for safety concerns.

---

## Modified services

PSE classifies work done on a service as a “modified service” when a customer requests a change in their secondary service that alters its current point of delivery or location to a new point of delivery without requiring the replacement of the entire service entrance conductor.

The modification of an underground service is different than the modification of an overhead service. In the modification of an underground service, the customer performs the modifications by adding, replacing, or relocating the secondary service conductors.

A modified service still must meet all the new service installation requirements. You are responsible for equipment from the meter socket into your building.

An electrical work permit must be present on your property for all work done on the customer side of the meter. You must apply for the permit before the work is started. After the work is completed, your local government agency must inspect the work before PSE can energize the service.

We know at times the electrical inspection is not completed or feasible by the time we arrive to reconnect your service. For modified services, if the permit is present and the work is completed, but the inspection has not been done, the service may still be energized by PSE if the work looks safe, clean, and completed. The inspection can take place the following day.

The customer requesting a modified service shall be required to pay PSE the costs of altering, transferring, or extending the existing electric service to the new point of delivery or location.

# Glossary

**Clearance** – A set distance between two objects.

**Conduit** – A listed or approved wireway with a smooth interior surface to permit easy drawing-in of the electrical conductors. A conduit may be metallic or nonmetallic, depending on its usage, in accordance with codes and Puget Sound Energy Standards.

**Corrosion Inhibitor** – Electrical joint compound used to retard oxidation of electrical connections.

**Customer Generation** – A generation facility installed by PSE customers that are interconnected and operated in parallel with PSE's electric distribution system through the electric service meter (net meter).

**Demand** – The maximum average kilowatt load used by the customer for a specific period of time during the billing period.

**Direct Burial** – The installation of electrical conductors in a trench, without the use of conduit.

**Disconnect Switch** – A single blade-type, visible and lockable disconnect.

**EUSERC** – Electrical Utility Service Equipment Requirements Committee

**Ground Mount** – A generation installation supported by its own independent structure.

**Guard Post** – A bollard or post designed to protect the meter installation or transformer from vehicular traffic.

**Guying** – Cables or braces used to relieve the strain of overhead conductors on masts and poles.

**High Leg** – (Also wild leg, delta leg) The phase leg that is at higher potential to ground than any other two-phase legs. This leg shall be identified in red.

**High-rise Building** – A structure meeting the definition set forth in the International Building Code.

**Instrument Transformer** – Current and/or potential transformers used in connection with metering equipment to monitor high current loads and/or high voltage potentials.

**Inverter** – An electronic device used to change dc current into ac current.

**Keybox or Keycards** – Permanently installed, locked box with keys enclosed, or a keycard screening monitor mounted on the outside of a building, for accessing the customer's premises to read, install, service, or remove Puget Sound Energy meters and/or electrical equipment during reasonable working hours.

**Manual Block Bypass (Circuit-Closing Block)** – A provision for paralleling the meter circuit, allowing the meter to be removed without interrupting service to the customer.

**Meter Jaw** – A spring-loaded receptacle installed inside a meter socket, interfacing the terminals of the meter to the source and load conductors of the service.

**Meter Loop** – Any provision in which an electrical meter may be installed. Does not include the service disconnect device.

**Meter Pole** – A pole which supports the metering equipment owned and maintained by the customer.

**Meter Base/Socket** – The mounting device consisting of meter jaws, connectors, and enclosure for accommodating socket-type meters. The mounting device may be either a single socket or a trough to accommodate more than one mounting unit.

**Multifamily Building** – A single structure comprised of two or more independent dwelling units having permanent provisions for living, sleeping, cooking, and sanitation.

**Municipal or State Inspector** – The qualified representative of a city or the Washington State Department of Labor and Industries, who has been authorized by governmental agencies to inspect electrical service installations on their behalf.

**NEC** – National Electrical Code

**Net Meter** – A PSE meter through which the customer generation is interconnected to the PSE electric distribution system. Net meters measure both energy delivered from PSE to the customer and energy returned to PSE from the customer.

**Nonresidential Buildings** – All structures that are not residential buildings or multifamily buildings, or where portions of such a building are intended for commercial, retail, or general public activities.

**Point of Attachment** – The point at which Puget Sound Energy's service conductors are attached to the customer's premises by an approved insulated clevis.

**Point of Delivery** – The location on the customer's premises where Puget Sound Energy's circuit and the customer's system are interconnected.

**Primary Voltage** – The higher voltage, before transformation, used to distribute electrical energy through neighborhoods and local areas. Normally in excess of 600 V.

**RCW** – Revised Code of Washington

**Safety Socket** – A three-phase self-contained meter base socket with provisions to de-energize the meter base without disconnecting the load.

**Seal** – The locking device used to secure meter and/or service entrance equipment to ensure safety and security for the unit.

**Secondary Voltage** – The lower voltage, after transformation, used to supply the customer with electrical energy. Normally less than 600 V.

**Self-Contained** – In reference to meter sockets: a device designed and rated to continuously carry the entire capacity of the service entrance equipment through the meter.

**Service Entrance Conductors** – Those conductors which extend between the customer's load center and point of delivery.

**Service Entrance Equipment** – Service conduit, conductors, weatherhead, meter base, enclosures, service disconnect, and load center.

**Service Mast** – The conduit above the meter used to provide mechanical protection for the service conductors and to support the service drop from PSE's system.

**Supply Side Tap** – A connection that is made on the line or utility side of the main service disconnect breaker.

**Temporary Service** – An electrical service installed by Puget Sound Energy to provide power to a customer on a temporary basis (12 months or less).

**WAC** – Washington Administrative Code

## Notes

---



