

## Addendum

### Electric Service Handbook: Single-Family Residential Projects Permanent and Temporary Service (Form #1218, 06/19)

#### Update to Underground Service Information

**Effective Date: 11/26/19**

This addendum is to clarify and correct information updated in the latest edition of this document.

**Chapters 2 & 5: Page 19 Customer-installed service line conduit installation requirements section, Page 54 Underground section, and Page 55 Figure 33**

- Conduit in the main service trench shall be 3-inch gray Schedule 40 from the PSE facility (pole/vault/handhole/pedestal) to the service riser/work pit.
- The knockout on the 200-amp meter base is 2-1/2 inches in diameter.
- **200-amp** services should be installed with a **non-continuous** conduit system using 3-inch conduit in the main service trench and a 2-1/2-inch conduit service riser to the meter base knockout because of the differing pipe sizes. Reference the Electric underground service installation requirements handout (Form 6080) for work pit requirements.

#### **NOTES**

1. PSE encourages customers to install 320-amp panels if the service requires 350 MCM to be installed for any portion of the service.
  2. An existing panel requiring an upgrade to larger than 200 amps, or an added motor load, may require excavation and the existing conduit be replaced with a 3-inch conduit or a new 3-inch conduit installed if no conduit existed previously.
- **320-amp** service with **continuous** or **non-continuous** conduit shall use a 3-inch conduit from end to end of the service.



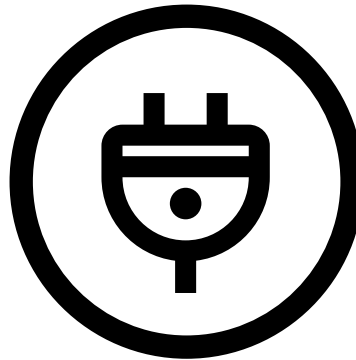

# **Electric Service Handbook**

March 2026

**Single-Family Residential Projects  
Permanent and Temporary Service**

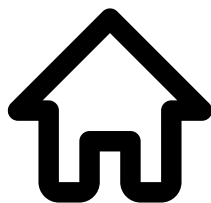

**©2026 by Puget Sound Energy**

All rights reserved. No part of this book may be reproduced or transmitted in any form or by any means, electronic or mechanical, including photocopying, recording, or information storage and retrieval system, without permission from Puget Sound Energy (PSE).



## Our commitments to appointments and service

We stand behind our service to you. We constantly track our performance and use your feedback to make improvements. We'll credit your bill if we fail to meet our service guarantees.

- Appointment service guarantee
- 24-consecutive-hour non-major storm power outage restoration guarantee
- 120-consecutive-hour power outage restoration guarantee

Conditions apply. For more information, visit [pse.com/guarantees](https://pse.com/guarantees).

# Table of contents

## Preface

- What this handbook contains . . . . . 1
  - PSE’s service availability . . . . . 1
- Codes, permits, and inspections . . . . . 1
  - Electrical service equipment inspection . . . . . 1
- Reconnecting existing electric service after repair or replacement . . . . . 2
- Scheduling/Timelines . . . . . 2
- Underground or overhead service? . . . . . 2
  - Which type of electrical system is available in your area? . . . . . 2
  - Underground service . . . . . 2
  - Overhead service . . . . . 3
  - Questions or assistance . . . . . 3
- Other electric service information . . . . . 4
- How to contact Puget Sound Energy . . . . . 5
- PSE’s service providers . . . . . 5
- Overview: new permanent and temporary electric service hookup . . . . . 6

## Chapter 1

### Steps to a successful permanent electric service installation

- Definitions . . . . . 7
- Service installation responsibilities . . . . . 7
  - Puget Sound Energy . . . . . 7
  - Customer . . . . . 8
- Starting the installation process . . . . . 8
  - Setting up an account or ordering a new service . . . . . 8
  - Will your project need engineering? . . . . . 9
- Choosing the right service size . . . . . 9
  - Service voltages . . . . . 9
  - Service sizes . . . . . 9
    - Sizes less than 200 A . . . . . 10
- Determining an approved meter location . . . . . 10
  - Customer-installed meter base/socket location . . . . . 10
- Know what’s below: Call 811 before you dig . . . . . 10
- Coordinating utility trenching and construction . . . . . 11
- Transformer locations . . . . . 11
- Liquefied propane tanks: clearances from ignition source . . . . . 15
- Outbuildings . . . . . 16
  - Service line installation responsibilities for outbuildings . . . . . 16
- Cost for service . . . . . 16
- Power quality, voltage flicker . . . . . 16

## Chapter 2

### Permanent underground service

Steps to a successful underground service installation . . . . .	17
Selecting a meter base/socket location . . . . .	18
Multiple metered services . . . . .	18
Service line trenches . . . . .	18
Trench routing/clearances . . . . .	18
Trench and backfill requirements . . . . .	18
Customer-installed service line conduit . . . . .	18
Customer-installed service line conduit installation requirements . . . . .	19
Continuous and discontinuous conduit systems . . . . .	19
When to choose continuous conduit . . . . .	20
When to choose discontinuous conduit . . . . .	21
Service entrance equipment . . . . .	22
Installation requirements . . . . .	22
Service entrance conduit size . . . . .	22
Permanent underground service for manufactured homes, 0–200 A . . . . .	25
Service equipment installation . . . . .	25
Meter base/socket requirements . . . . .	25
Remote metering (meter loop) for underground residential services . . . . .	27
What is remote metering? . . . . .	27
Requirements for residential remote metering, 200 A or less . . . . .	27
320 A, 400 A, and larger panels . . . . .	28
Remote services greater than 800 A . . . . .	28
Meter post and pedestal locations . . . . .	28

## Chapter 3

### Permanent overhead service

Steps to a successful overhead service installation . . . . .	29
Selecting a meter base/socket location . . . . .	30
Clearance requirements . . . . .	30
Service line ground clearance . . . . .	30
Maintenance of your service around trees . . . . .	30
Attachment of service conductor . . . . .	30
Minimum clearances from structures, building openings, and gas meters . . . . .	31
Intermediate service pole . . . . .	32
Service mast . . . . .	32
Service mast requirements . . . . .	32
Height requirements . . . . .	32
Additional mast supports (guy or brace) . . . . .	35
Screw-in service knobs . . . . .	35
Service entrance equipment installation requirements . . . . .	35

Manufactured homes . . . . .	36
Meter base/socket installation requirements for manufactured homes . . . . .	36
Customer-owned meter pole . . . . .	36
Meter pole requirements . . . . .	36
Meter pole locations . . . . .	37
Guying . . . . .	37
Setting . . . . .	37
Service length . . . . .	37
Minimum pole length requirement . . . . .	38

## Chapter 4

### Primary line extensions

Customer responsibility . . . . .	40
Inspection/Coordination . . . . .	40
Site preparation . . . . .	40
Customer-provided trench . . . . .	41
Trench width . . . . .	41
Trench excavating requirements . . . . .	43
Trench and backfill requirements for primary electric line extension trenches (no PSE gas) . . . . .	44
Trench and backfill requirements for primary electric line extension trenches (with PSE gas) . . . . .	44
Vaults . . . . .	44
Vault excavation procedure . . . . .	44
Vault location and access . . . . .	48
Vault backfill material . . . . .	48
Customer-supplied conduits . . . . .	49
Terminating conduit at transformer . . . . .	49
Excavating to expose existing buried primary voltage power lines . . . . .	49

## Chapter 5

### Meter installation

Service rating options . . . . .	50
Responsibilities . . . . .	50
Puget Sound Energy . . . . .	50
Customer . . . . .	50
Customer equipment . . . . .	50
Meter bases/sockets . . . . .	51
General requirements . . . . .	51
Meter base/socket location . . . . .	51
Labeling . . . . .	51
Grounding requirements . . . . .	51
Disconnecting means and its sequence . . . . .	51

Meter/panel combo units . . . . .	52
Residential meter bases with NEC required disconnect . . . . .	52
Residential modified services installing new/upgrading existing with NEC required disconnect style meter (occupied structure) . . . . .	52
Clearance requirements for meter installations . . . . .	53
200 A services . . . . .	54
Single-family residential. . . . .	54
Underground . . . . .	54
Overhead . . . . .	55
Outbuildings (overhead or underground service). . . . .	55
400 A self-contained services . . . . .	56
Underground . . . . .	56
Overhead . . . . .	57
Outbuildings (overhead or underground service). . . . .	57
400 A current transformer (CT) services. . . . .	58
Services over 400 A. . . . .	58

## Chapter 6

### Customer generation

Responsibilities . . . . .	60
Puget Sound Energy. . . . .	60
Customer . . . . .	60
General requirements. . . . .	61
How to apply for interconnection . . . . .	61
Interconnection system diagrams. . . . .	62
Meter location . . . . .	62
Meter socket requirements. . . . .	63
Labeling and signage requirements . . . . .	63
Disconnect switch requirements . . . . .	64
Commissioning . . . . .	65
Testing . . . . .	66
Resources . . . . .	66

## Chapter 7

### Temporary services

What this chapter contains. . . . .	67
Definition . . . . .	67
Obtaining your temporary service from existing power facilities . . . . .	67
Scheduling . . . . .	68
Customer charge for service . . . . .	68
Temporary meter base/socket requirements . . . . .	68
Temporary underground services. . . . .	68
Meter location. . . . .	68
Trenching and excavation requirements . . . . .	69
Underground temporary service installation process . . . . .	70

Temporary overhead services . . . . .	72
Meter location . . . . .	72
Service line path requirements . . . . .	72
Clearance requirements . . . . .	72
Overhead temporary service installation process . . . . .	73

## Chapter 8

### Disconnection and modification of service

Disconnection of your meter . . . . .	75
Residential modified services installing new/upgrading existing with NEC required disconnect style meter (occupied structure) . . . . .	75
Modified services . . . . .	76

<b>Glossary</b> . . . . .	78
---------------------------	----

### List of Tables

Table 1	Types of electric services . . . . .	4
Table 2	Standard voltages for residential customers . . . . .	9
Table 3	Service sizes available from PSE . . . . .	9
Table 4	Color codes for locating utilities . . . . .	11
Table 5	Clearances for padmount transformers . . . . .	12
Table 6	Service line installation responsibilities . . . . .	16
Table 7	Current transformer (CT) enclosure dimensions (minimum) . . . . .	58
Table 8	Example of overhead and underground modified service . . . . .	77

### List of Figures

Figure 1	Underground facilities . . . . .	2
Figure 2	Overhead facilities . . . . .	3
Figure 3	Clearances for transformers . . . . .	12
Figure 4	Clearances for transformers from structures . . . . .	13
Figure 5	Clear working space for padmount transformers and aboveground J-box enclosures . . . . .	14
Figure 6	Minimum clearances from oil-filled equipment to LP, hazardous liquid, or fuel tanks . . . . .	14
Figure 7	Minimum clearances from LP storage tanks to sources of ignition . . . . .	15
Figure 8	Typical underground service from overhead power facilities . . . . .	17
Figure 9	Example of continuous conduit in underground electric service . . . . .	20
Figure 10	Example of discontinuous conduit in underground electric service . . . . .	21
Figure 11	Two types of meter bases/sockets for permanent underground service . . . . .	23
Figure 12	401–800 A service entrance equipment . . . . .	24
Figure 13	Permanent underground service for manufactured homes, 0–200 A . . . . .	26
Figure 14	Remote metering for underground residential services on meter post . . . . .	27
Figure 15	Remote metering for underground residential services on meter pad . . . . .	28
Figure 16	Typical overhead service installation . . . . .	30
Figure 17	Minimum overhead service line vertical clearances from ground level . . . . .	31

Figure 18	Minimum clearances over other structures . . . . .	31
Figure 19	Intermediate service pole location . . . . .	32
Figure 20	Unguyed service masts . . . . .	33
Figure 21	Guyed service masts . . . . .	34
Figure 22	Butt gain . . . . .	36
Figure 23	Permanent overhead meter pole installation . . . . .	39
Figure 24	Conduit riser placement detail . . . . .	41
Figure 25	Typical joint utility trench with primary voltage cable on your private property . . . . .	42
Figure 26	Minimum dimensions and excavation requirements for a single-phase padmount transformer vault . . . . .	45
Figure 27	Aboveground junction box vault excavation . . . . .	45
Figure 28	Minimum dimensions of excavation requirements for small secondary handholes . . . . .	46
Figure 29	Joint trench detail for secondary pedestals and vaults . . . . .	47
Figure 30	Electrical vault access road cross-section . . . . .	48
Figure 31	Meter base/socket minimum clearances . . . . .	53
Figure 32	Recessed meter installation clearances . . . . .	54
Figure 33	Residential meter socket wiring diagrams . . . . .	55
Figure 34	Typical arrangement of service conductors for underground class 320 meter base/socket . . . . .	56
Figure 35	Typical arrangement of service conductors for overhead class 320 meter base/socket . . . . .	57
Figure 36	Instrument-rated (CT) meter bases/sockets . . . . .	58
Figure 37	Single-phase CT mounting base . . . . .	59
Figure 38	Trenching requirements for power stubout . . . . .	69
Figure 39	Temporary underground service installation . . . . .	71
Figure 40	Minimum clearance requirements upon installation . . . . .	73
Figure 41	Temporary overhead service installation . . . . .	74

# Preface

This handbook is your guide to Puget Sound Energy’s (PSE) requirements for new, altered/modified, or temporary electric service for permanent single-family residential structures. We have also included additional requirements for electric service to outbuildings (barns, shops, pump houses, garages, etc.).

---

## What this handbook contains

In this handbook you will find answers to questions such as:

- What are the installation requirements for permanent and temporary underground and overhead service?
- How do I choose the right service size?
- What are the trenching requirements?
- How do I locate existing underground utilities before I dig?

### PSE’s service availability

General boundaries for PSE’s gas and electric service area are available on [pse.com/construction-services](https://www.pse.com/construction-services). A Customer Construction Services (CCS) Representative can help you to determine the closest available service line and can provide you with cost information for establishing new service.

---

## Codes, permits, and inspections

This handbook should only be used as a guide. It does not cover all possible federal, state, or local code requirements. It is your responsibility to ensure that your project complies with the most recent issue of the National Electric Code (NEC) and any other federal, state, or local codes that may apply.

This handbook shall not be interpreted to conflict with the regulations of the state of Washington or other regulatory bodies having jurisdiction. PSE’s metering requirements may be more stringent. Local codes and requirements related to the planned work should be addressed before any construction begins.

### Electrical service equipment inspection

Once your service equipment is installed, the state of Washington, or the city with jurisdiction over your area, requires that your installation pass an electrical inspection before PSE can energize your system.

**NOTE:** It is your responsibility to request an electrical inspection.

Electrical inspections for most areas in the PSE service territory are done by the Washington State Department of Labor and Industries. However, electrical inspections are performed by city personnel in several jurisdictions. Please consult [pse.com/construction-services/permits-and-inspections](https://www.pse.com/construction-services/permits-and-inspections) for a list of the cities and current contact information.

---

## Reconnecting existing electric service after repair or replacement

All electrical equipment and wiring on the customer side of the meter (including meter base and service masts) are owned and maintained by the customer. Therefore, **you are responsible for any repair or replacement of storm-damaged or failed metering equipment.** If you must repair/replace equipment of this kind, your service may need to be de-energized or disconnected.

For more information, refer to Chapter 8, Disconnection and Modification of Service, of this handbook or contact your CCS Representative at **1-888-321-7779**.

---

## Scheduling/Timelines

The time needed for engineering, scheduling, and construction of the work will vary depending upon the complexity of the job, possible right-of-way permits, easements, and the volume of work requested by PSE customers. Contact your CCS Representative at **1-888-321-7779** for current construction scheduling

---

## Underground or overhead service?

**Which type of electrical system is available in your area?**

The two types of permanent services are underground and overhead.

You can determine if PSE's system is underground or overhead by checking for our facilities along your road. If the power system is underground, you'll see facilities like those in Figure 1. If the power system is overhead, a series of poles similar to Figure 2 will be visible.

Use Table 1 to help you determine which type of electrical service can be provided. For help determining which type of system is in your area, call your CCS Representative at **1-888-321-7779**.

**Underground service**

If your area is served underground, one or more underground facilities should be visible (see Figure 1). Please request a permanent underground service (Chapter 2).

**Figure 1** Underground facilities

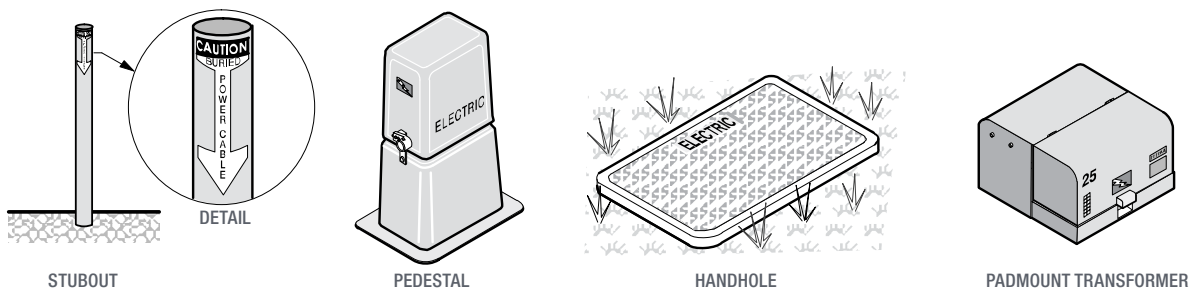

**Overhead service**

If the power system in your area is overhead, poles should be visible (see Figure 2). Please request a permanent overhead service (Chapter 3).

**Figure 2**

Overhead facilities

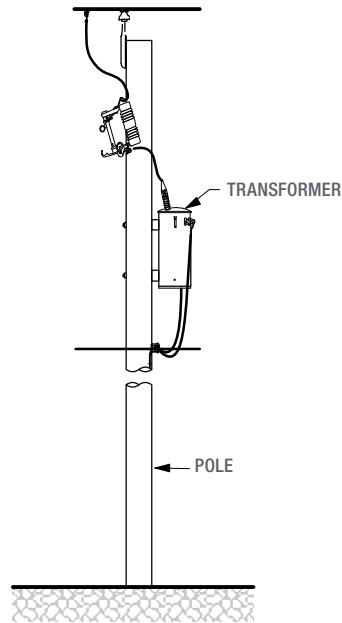

**Questions or assistance**

If none of the items in Figures 1 or 2 exist in your area, or if you have questions, call **1-888-321-7779** and a CCS Representative will be glad to assist you.

**Table 1** Types of electric services

If available electrical system is . . .	And if . . .	Then your service line will be . . .
Underground	Your new meter location is less than 225 ft.* from our nearest padmount transformer (see Figure 1).  <b>NOTE:</b> If your new meter location is more than 225 ft. from our nearest underground transformer, an additional transformer may be required.	Underground
Overhead	The new meter location is less than 200 ft.* from our nearest power pole. The service originates from the pole. The pole has a transformer on it (see Figure 2).	Underground
Overhead	The new meter location is less than 125 ft.* from our nearest power pole. The pole has a transformer on it (see Figure 2). Your service line does not cross anyone else’s property.	Overhead or Underground

**NOTE:** If your situation does not fit the criteria presented, please contact your PSE project manager.

\* Based on the typical voltage flicker calculations on underground system and sag calculations on overhead system. Contact a CCS representative regarding evaluation for type of service for your service request.

---

### Other electric service information

If you need information on the installation of permanent or temporary multifamily and nonresidential services, you will find it in the PSE **Electric Service Handbook for Non-residential Projects, Permanent and Temporary Service (Form 1220)**.

Puget Sound Energy’s guides and handbooks are available at the [Construction Services Guides and Handbooks web page](#).

---

## How to contact Puget Sound Energy

You can obtain further information by contacting us through the following:

- Go to [pse.com/construction-services](https://pse.com/construction-services)
- Or call PSE Customer Construction Services (CCS) at **1-888-321-7779**  
Monday through Friday, 7 a.m. – 5 p.m.

If you have questions about Energy Efficiency Programs:

- Go to [pse.com/rebates](https://pse.com/rebates)
- Or call PSE Energy Advisors at **1-800-562-1482**  
Monday through Friday, 8 a.m. – 5 p.m.

If you have general questions regarding your account, such as changing service or questions about your bill:

- Go to [pse.com/customer-service/help-center/my-account](https://pse.com/customer-service/help-center/my-account)
- Or call Customer Service at **1-888-225-5773**; TTY **1-800-962-9498**  
Monday through Friday, 7:30 a.m. - 6:30 p.m.

If you have an emergency or a service delivery issue, please call:

- Customer Service at **1-888-225-5773**; TTY **1-800-962-9498**  
24 hours a day, 7 days a week.

---

## PSE's service providers

PSE contracts with two partner companies to provide construction services: Potelco, Inc. and InfraSource Construction LLC. The employees who install your service may work for these service providers on PSE's behalf.

## Overview: new permanent and temporary electric service hookup

---

**This information applies only if PSE has existing power facilities in your area.**

If electric power is not readily available, please contact: **Customer Construction Services 1-888-321-7779** or [pse.com/construction-services](https://www.pse.com/construction-services)

### Single-family residential customer responsibilities

- Determine if you need overhead or underground service.
- Call PSE to set up an account and submit an order. Allow adequate time for possible engineering, right-of-way permits, and easement review.
- Obtain an electrical work permit.
- If temporary service, install temporary service facility and meter base.
- If permanent service, determine the service size amp rating you want (200, 320, or 400 A).
- Determine an approved permanent meter location.
- Ensure that existing underground utilities are located before you dig. Call 811 two business days prior to digging for a free service that will mark the location of underground lines.
- Prepare job site by providing a clear path/trench for your service line for proper vault entrance requirements per PSE standards.
- Provide site preparation and installation requirements (site plans) according to PSE installation standards in the **Gas and Electric Underground Service Installation Requirements (Form 3061)**.
- Obtain an approved electrical inspection.
- After the electrical inspection has been completed and approved, request that PSE install and energize your system.

### PSE's responsibilities

- Connect temporary service.
- Determine if engineering is required.
- Install your overhead or underground permanent service line conductors.
- Install your meter and energize your system

### Scheduling/ time frame

- If engineering is not required, services are typically installed and energized 3 to 5 days after you have passed your inspection. Engineering, right-of-way permits, etc., **can extend time frames by 8 weeks or more.**

### Permanent and temporary service charge

- Charges vary due to the type of service you request and the type of system we have in your area. Contact your Customer Construction Services Representative for current rate information.

# Chapter 1

## Steps to a successful permanent electric service installation

---

### Definitions

PSE defines a single-family residence as a structure that is:

- Located on a legal residential lot.
- Approved for occupancy as a permanent single-family residence by the local governing agency or agencies.
- A parcel where the lot line is extended to the public thoroughfare, even if the unit(s) shares a common wall(s) with other like living units, such as in zero-lot-line construction.

A mobile or manufactured home will be considered a single-family residence if it meets the above requirements, and:

- Is permanently located on a foundation.
- Has had the axles and wheels removed.
- Meets all other requirements for a mobile home permit as required by the local governing agency or agencies.

**NOTE:** A mobile or manufactured home located in a mobile home park in which each home owner DOES NOT own the parcel that the home sits on does not qualify as a single-family residence.

---

### Service installation responsibilities

Installing new electrical service to your single-family residence is a joint project between you and PSE.

#### Puget Sound Energy

PSE is responsible for:

- Installing the service line conductors to a customer-installed and maintained service mast or underground meter service riser.
- Installing the meter in a customer-installed and maintained meter base/socket.
- Energizing your system.

**Customer**

You are responsible for:

- Determining if you need overhead or underground service.
- Setting up an account and submitting an Application for Service.
- Obtaining an electrical work permit.
- Determining the service size amp rating you want.
- Determining an approved meter location.
- Providing site preparation and installation requirements according to PSE installation standards in the **Gas and Electric Underground Service Installation Requirements (Form 3061)**.
- Before any digging project, **calling the 811 “Call Before You Dig”** hotline a minimum of two business days before digging.
- Installing the meter base/socket on the outside wall in an approved location.
- Installing all the electrical wiring inside your residence.
- Obtaining a city or state inspection and approval of your installation.
- After your electrical inspection is complete, calling PSE to request that your service be installed and energized.
- Keeping your meter base/socket accessible to PSE
- Coordination with other utility companies being installed in a joint trench.

---

## Starting the installation process

### Setting up an account or ordering a new service

You may establish your billing account when you are ready to initiate your temporary service order, order your permanent service, or after the state electrical inspection is complete and your trench is ready (if applicable).

To establish an account with PSE, call CCS at **1-888-321-7779**. The CCS Representative will ask for your billing information and the address for new service. (New addresses are obtained from the U.S. Postal Service or the County Addressing Department.)

To order a new service, submit an Electric Service Application Single-Family Residential 100E to your CCS Representative. All forms can be downloaded from [pse.com/construction-services](https://pse.com/construction-services).

**Will your project need engineering?**

A CCS Representative will ask you the following questions to help determine how your project is handled:

- What kind of residential building is this service for (home, barn, shop, etc.)?
- What is the building's square footage?
- What kind of electrical or gas appliances will you have (furnace, heat pump, air conditioning, water heater, etc.)?
- What size service panel will you be installing?
- When will you be ready for service?
- Do you need underground or overhead service?
- Will any other utility be sharing the trench?
- Is the PSE utility connection point adjacent to your property or across the street?

**NOTE:** If a transformer or electrical service stubout is located on your property, your project probably will not require engineering. If no transformer or stubout is available, your project will require engineering and/or needs a municipality right-of-way permit, and our CCS Representative will ask you to complete and submit an Electric Service Application Single-Family Residential 100E. This form can be downloaded at [pse.com/construction-services](https://pse.com/construction-services).

---

## Choosing the right service size

**Service voltages**

PSE offers their customers the voltages shown in Table 2.

**Table 2**

Standard voltages for residential customers

Service type	Voltage
Single-phase	120/240 V, 3-wire *
Three-phase	120/208 V, 4-wire 277/480 V, 4-wire

\* Available for loads to a maximum demand of 100 kW. Larger loads may be served, if determined feasible by a PSE engineer. All motors must be rated 7-1/2 HP or less.

**Service sizes**

PSE offers several service sizes for single-family residential structures and for outbuildings. The service size you need depends on both the size of your home and the power requirements of the equipment you will be installing in it. Table 3 explains the sizes that are available.

**Table 3**

Service sizes available from PSE

Voltage	Ampere rating	Typical use
120/240	200 A	0-1500 Sq. Ft. or 1501-2500 Sq. ft.
	320 or 400 A	2501-3500 Sq. ft.
	Over 400 A	greater than 3500 Sq. ft.

**Sizes less than 200 A**

You may install a service panel or meter base/socket that is sized less than 200 A, but the service line and meter that PSE installs will be sized as if you were installing a 200 A service.

If you are installing an underground service that is less than 200 A, your meter base/socket must meet the dimensional requirements for a 200 A underground meter base/socket (refer to Chapter 5, Meter Installation, located in this handbook).

---

## Determining an approved meter location

**Customer-installed meter base/socket location**

**NOTE:** Only authorized and qualified PSE personnel shall install and remove meters.

You are required to install your meter base/socket in compliance with the requirements in Chapter 5. All locations are subject to approval by a PSE Representative.

If you have questions regarding meter locations, call your CCS Representative at **1-888-321-7779**.

Meter base/sockets, including current transformer (CT) enclosures, must be located:

- Outside.
- On the front 1/3 of your home closest to normal drivable public access.
- In an area that is not subject to being fenced-in (patios, decks, porches, breezeways and backyards are bad locations).
- On a structure that is owned by you.

These approved locations allow us to:

- Read your meter in a cost-effective manner.
- Maintain your meter efficiently.
- Disconnect your service if there is a fire.

**NOTE:** Refer to the **Gas Meter Clearances and Service Installation Requirements** ([Form 3885](#)) and **Electric Underground Service Installation Requirements** ([Form 6080](#)) for more information.

---

## Know what's below: Call 811 before you dig



**Know what's below.  
Call before you dig.**

Before excavating, Washington law requires you to call 811 to locate underground utility lines. Doing so will enable you to avoid potential injury, fines, costly repair of PSE utility facilities, and electric or natural gas service disruptions. Call 811 at least two to five full business days prior to digging. (For example, call Wednesday to dig on Monday.) When you call, an operator will record information about your dig and notify affected utility companies, including PSE. PSE locates and marks its own lines for free, but privately owned utility lines must be located by a separate vendor, typically for a fee.

The locate service uses the following color codes to identify underground utilities:

**Table 4** Color codes for locating utilities

Color	Utility
White	Proposed excavation area
Pink	Temporary survey markings
Red	Electric power lines, cables, conduit, and lighting cables
Yellow	Gas, oil, steam, petroleum, or gaseous materials
Orange	Communication, alarm or signal lines, cables, or conduit
Blue	Potable water
Purple	Reclaimed water, irrigation, and slurry lines
Green	Sewers and drain lines

**NOTE:** Use white paint to mark the area within which you want utility locations.

Once all utilities are located:

- Do not dig with machinery within 3 feet of the locate marks.
- Hand dig to expose all utilities to be crossed.

---

## Coordinating utility trenching and construction

New construction typically involves the installation of telephone cables, cable television cables, and natural gas lines; as well as electric power cables.

It is the responsibility of you and your builder to notify each utility about your intended electric service installation as well as all other utilities providing service to your new structure.

If you need a PSE gas service, please call 1-888-321-7779 and complete an application for gas service at [pse.com/construction-services](https://www.pse.com/construction-services).

---

## Transformer locations

PSE will install padmount transformers using the clearances listed in Table 5 and shown in Figures 3 through 6.

Clearances between padmount transformers and structures must be measured from the metal portion of the transformer closest to the building or structure (including any overhangs).

A clear and level working space is necessary for the operation and maintenance of padmount transformers (Figure 6).

The working space should be free from obstructions such as trees, shrubbery, poles, buildings, retaining walls, structures, fences, fire hydrants, utility pedestals, decorative screens, ditches, streams, roadways, etc.

Shrubs, hedges, plants, ground cover, or other vegetation with invasive root, vine, or branch systems that may grow underneath or into PSE equipment are prohibited.

**Table 5** Clearances for padmount transformers

Feature	Clearance distance
Combustible walls or roof (including stucco).	10 feet. See Figure 4.
Noncombustible walls (including brick, concrete, steel, and stone), provided the side of the transformer facing the wall does not have doors. Materials that pass UBC Standard 2-1 or ASTM E136-79 are considered to be noncombustible.	3 feet. See Figure 4.
Fire sprinkler valves, standpipes, and fire hydrants.	6 feet. See Figure 3
Doors, windows, vents, fire escapes, and other building openings.	10 feet. See Figure 3.
The water's edge of a swimming pool or any body of water.	15 feet. See Figure 3.
Individual domestic and irrigation wells.	100 feet. See Figure 3.
Facilities used to dispense or store LP or hazardous liquids or fuels.	20 feet. See Figure 6.
Gas service meter relief vents.	3 feet. See Figure 3.
Generators, customer-owned transformers, etc.	6 feet.

**Figure 3** Clearances for transformers

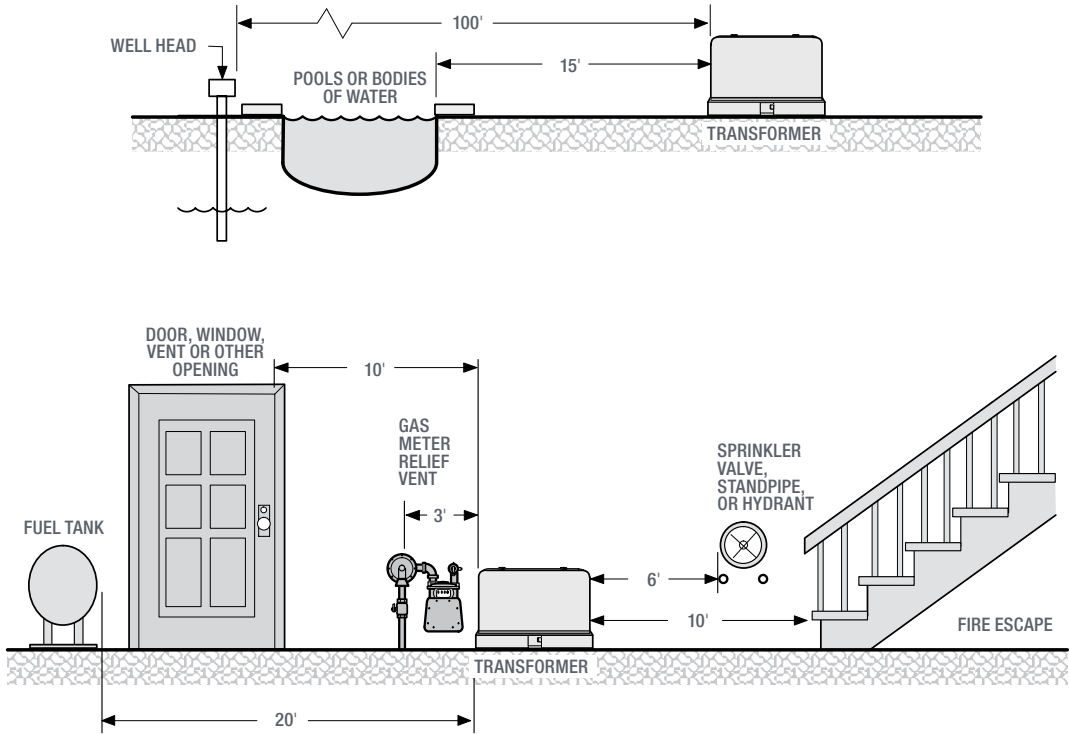
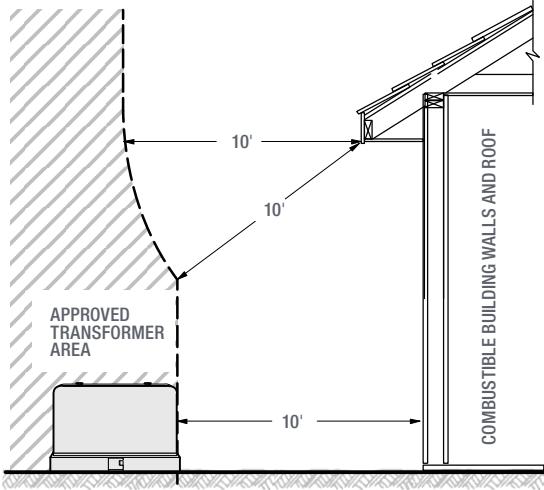
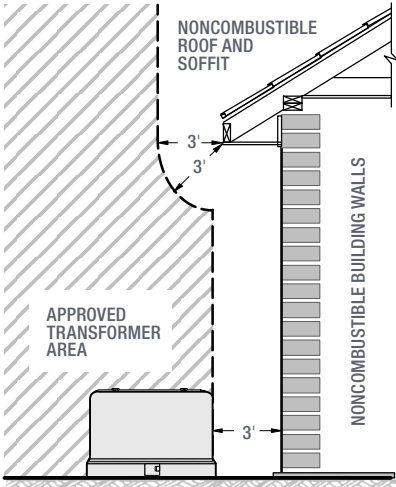

Figure 4 Clearances for transformers from structures



TRANSFORMER CLEARANCES FROM COMBUSTIBLE SURFACES



TRANSFORMER CLEARANCES FROM NONCOMBUSTIBLE SURFACES

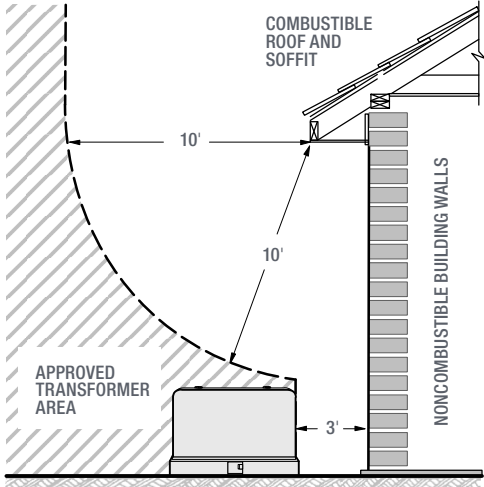

TRANSFORMER CLEARANCES FROM NONCOMBUSTIBLE WALLS WITH COMBUSTIBLE ROOFING

Figure 5 Clear working space for padmount transformers and aboveground J-box enclosures

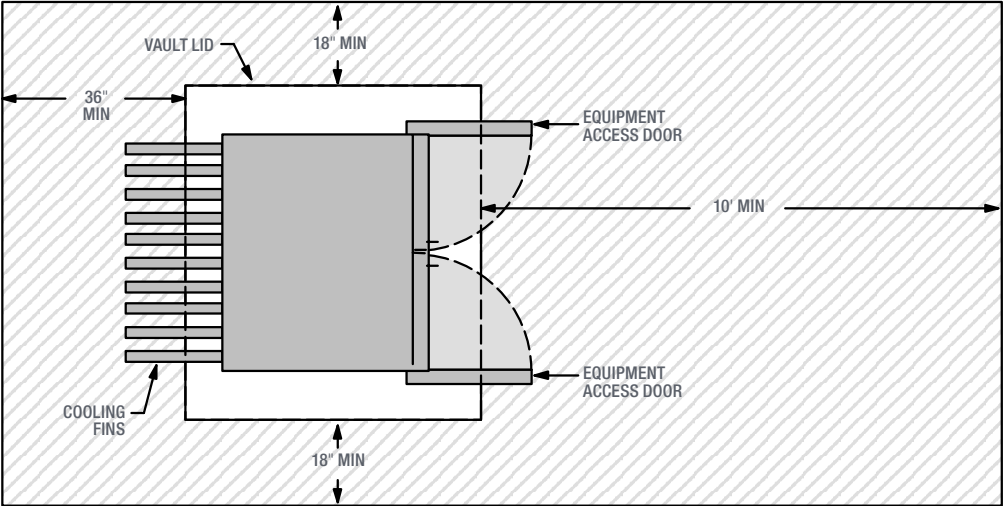
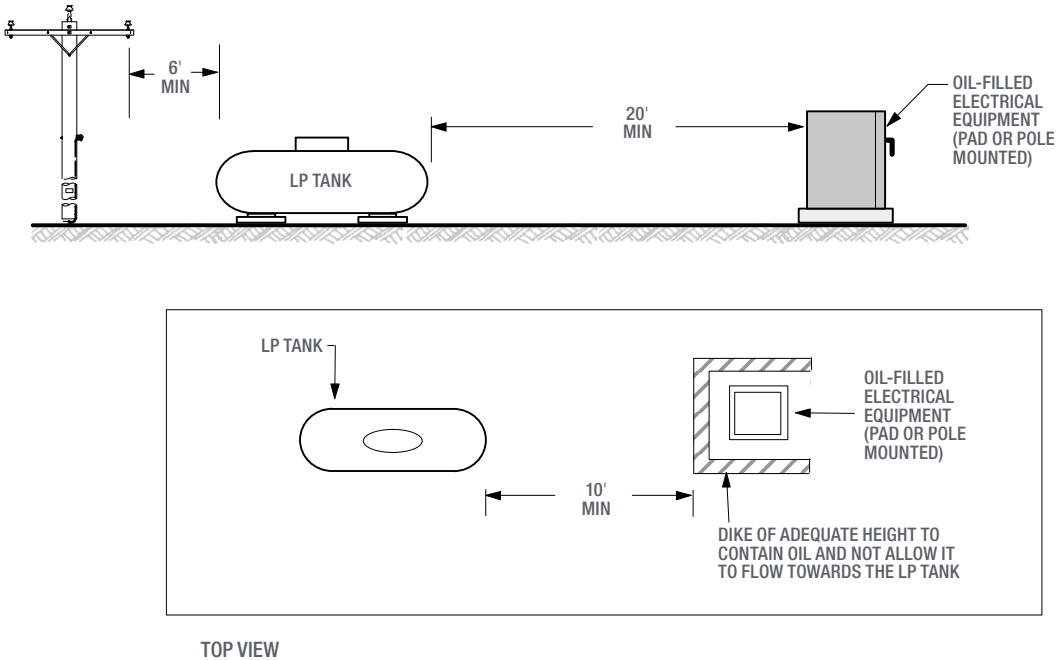

Figure 6 Minimum clearances from oil-filled equipment to LP, hazardous liquid, or fuel tanks



## Liquefied propane tanks: clearances from ignition source

If there are liquefied propane (LP), hazardous liquid, or fuel tanks on your property, the following minimum clearances apply from PSE's padmounted transformer or the ignition source (see Figures 6 and 7).

- All LP tanks must be at least 6 feet from a vertical plane extending down from an overhead primary voltage line.
- Consumer storage LP tanks must be at least 5 feet from any source of ignition, such as electric meter bases, submersible transformers, secondary handholes or pedestals, or padmount switches.
- The fill connection, gauge connection, or vent on the LP tank must be at least 10 feet from any source of ignition.

Figure 7

Minimum clearances from LP storage tanks to sources of ignition

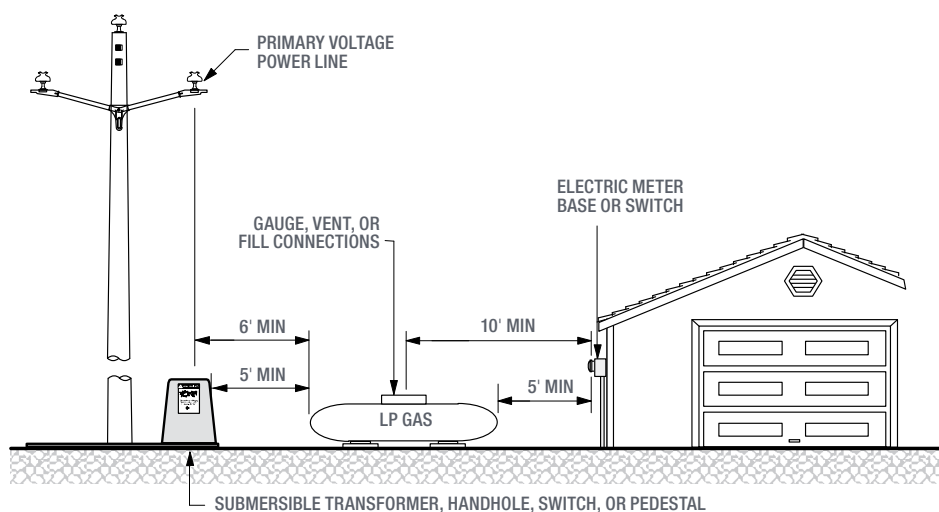

---

## Outbuildings

An outbuilding is a stand-alone structure that is located on residential property and is not a living space. Typical outbuildings are barns, pump houses, garages, shops, and storage sheds.

### Service line installation responsibilities for outbuildings

An underground service line to an outbuilding is installed by the customer or PSE, depending upon the intended use of the outbuilding (see Table 6).

If you want PSE to install a separate service to your outbuilding, refer to the Service Installation Responsibilities section at the beginning of this chapter.

Table 6

Service line installation responsibilities

If the primary use of Outbuilding is for . . .	Service line will be installed and maintained by . . .
Commercial purposes or a pump house for a multifamily/community well serving more than 2 households.	Customer
General residential (garages, shops, small barns and well pump houses serving up to 2 households).	Puget Sound Energy

**NOTE:** Installation costs and billing rates are different for each type of primary use of outbuildings. Contact your CCS Representative at **1-888-321-7779** for more information.

---

## Cost for service

Charges vary depending on the location of existing electrical facilities, the type of service you are requesting, and the distance to run service from our facilities to your home.

Contact CCS at **1-888-321-7779** to determine the cost for service.

---

## Power quality, voltage flicker

In your Application for Service, PSE requires the locked rotor starting currents (in amps) for the largest single-phase and three-phase motors that draw in-rush current. After we determine the size of transformer required to serve the new load of the facility, we will calculate the percent voltage flicker (from the motor's starting current) at the point of service and provide that number to you.

If this voltage dip exceeds PSE's limits based on facility type, the transformer size must be increased to compensate for this. **You will be responsible for the difference in cost of the larger transformer**, or you will need to install sufficient controls to bring flicker back within PSE's limits.

**NOTE:** We will size PSE's facilities to provide a level of voltage flicker that is normally acceptable to customers. If you need to be served with a higher quality of service, contact your CCS Representative.

# Chapter 2

## Permanent underground service

---

### Steps to a successful underground service installation

The following list details the key steps in the installation of your underground service resulting in PSE's installation of your underground service line and meter (see Figure 8).

- Confirm where your service line will originate by contacting Customer Construction Services (CCS) at **1-888-321-7779**.
- Call PSE to set up an account and submit an order. Allow a minimum 4-12 weeks for possible engineering, right-of-way permits, and easement review.
- Obtain an electrical work permit.
- Determine an acceptable location for your meter base/socket (see Chapter 5).
- Coordinate with PSE project manager for any work in right-of-way.
- Order underground utility locate service by contacting the 811 "Call Before You Dig" hotline a minimum of two business days before digging.
- Dig a trench and provide proper conduit between your meter location and the service line origination (transformer, pedestal, handhole, pole, or stubout).
  - » Provide 4-foot-square work pits at poles, stubouts, pedestal, handholes, and meter service entrance.
  - » Provide conduit for electrical service lines and a minimum of 3/8-inch pull rope.
- Install your meter base/socket service entrance equipment.
- Obtain a city or state electrical inspection and approval of your installation.
- Call CCS at **1-888-321-7779** to have your service installed and energized.

**Figure 8** Typical underground service from overhead power facilities

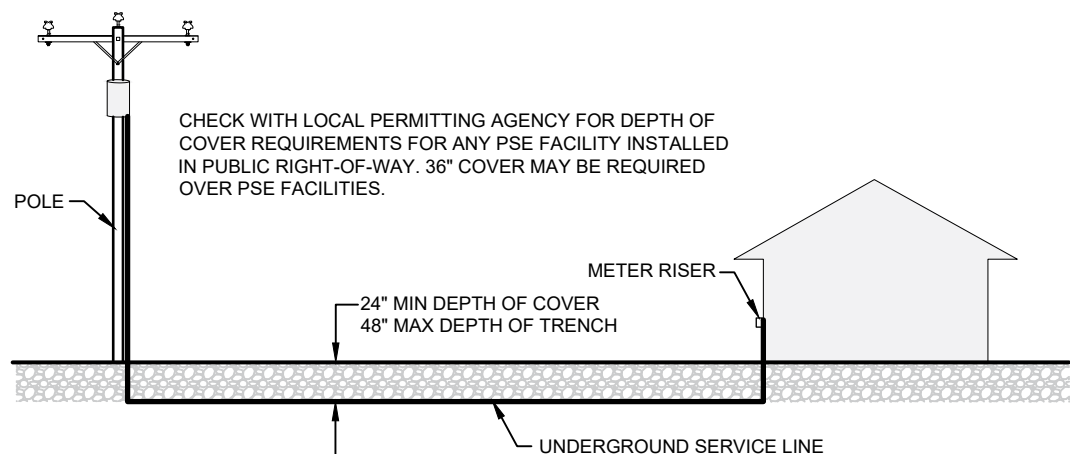

---

## Selecting a meter base/socket location

When choosing your meter base/socket location, be sure to consider the types of terrain where your service line will be buried. Since PSE is responsible for repairing your service line if it fails, the path you select is subject to being dug up. Therefore, we recommend that the service line route be accessible for repairs and excavation.

**NOTE:** Refer to the general requirements section in Chapter 5, Metering Installation, when selecting a location for your electric meter base and socket.

### Multiple metered services

If a residential class customer installs a bus gutter or meter-pack enclosure to set two meters (one meter for the house, the other for the shop, barn, garage, etc.) on a single piece of property being billed to the same individual, PSE will run a single service line to a remote permanent meter base at the customer's request. However, the single line must accommodate the kW load and limit the voltage drop and voltage flicker to within PSE's standards.

**NOTE:** PSE will not run a single service line to a bus gutter or meter-pack that serves multiple residential class customers residing on differing properties with separate legal ownership.

**NOTE:** Alternate Dwelling Units (ADUs) with different mailing address must be metered separately (One meter on each home).

---

## Service line trenches

This section refers to the illustrations found in the **Electric Underground Service Installation Requirements (Form 6080)** available at [pse.com/construction-services](http://pse.com/construction-services).

### Trench routing/clearances

The routing of a customer-provided trench must maintain a minimum of 5 feet from septic tanks and a minimum of 10 feet from drain fields.

### Trench and backfill requirements

PSE will allow **customer-owned facilities** within the service line trench if the following minimum horizontal clearances from PSE facilities are maintained:

- 18 inches minimum for customer-owned tight-line sewer (not tile), storm drain lines, roof drain lines, natural gas line, propane gas line, fuel oil line, and water mains up to 6 inches.
- 12 inches minimum for water services, irrigation pipes, lighting, security and electric supply circuits, closed-system roof drains/storm drains (not French drains), and culverts.

**NOTE:** The **Electric Underground Service Installation Requirements (Form 6080)** illustrates the service trench requirements in detail.

### Customer-installed service line conduit

If your service line will be crossing under any permanent structure (driveways, sidewalks, decks, patios, rockeries, retaining walls, or through your backyard), you are required to provide and install conduit under those obstructions. \*

You are required to provide an electrical service line conduit for services 100 feet long or less. However, PSE recommends the use of conduit for all services.

\* Any portion of the service conductor not in conduit may not be under a drive path or hard surface.

### Customer-installed service line conduit installation requirements

- The service line conduit shall be gray, schedule 40 PVC conduit with a minimum 3 inches in diameter for all runs.
- White water pipe or green sewer pipe is not acceptable.
- The service line conduit shall contain no more than a total of 180 degrees of bends of which no individual bend is less than a 24-inch radius.
- Install a minimum of 3/8-inch pull rope, or 3/8-inch polyester pulling tape, in the conduit. Strength of the pulling rope or tape shall meet or exceed 1800-pound rated tensile strength.
- Stop the conduit 4 feet from the pole in the work pit with the pole butt exposed.
- Do not provide a conduit elbow at the base of PSE's pole, and do not install conduit on a PSE pole.
- When installing conduit at a transformer, stop 3 feet from the entrance at the bottom of the transformer minipad (Figures 9, 10 and 24).

**NOTE:** Details of a service line trench with customer-installed conduit is shown in the **Electric Underground Service Installation Requirements (Form 6080)**.

---

## Continuous and discontinuous conduit systems

A continuous conduit system is defined as a section of conduits permanently glued together and installed between the location of available power (e.g., PSE power pole, padmount transformer, pedestal, handhole, or stubout) and the meter base without any points of separation where it exists underground (e.g., conduit work pits). See Figure 9.

A discontinuous conduit system is defined as multiple sections of conduits installed between the location of available power and the meter socket with points of separation between sections where they exist underground (see Figure 10).

Choosing to install a continuous conduit system has its advantages and disadvantages:

- An advantage of a continuous conduit system is that the PSE electrical crew does not require an excavated work pit to be open at the location of your meter socket on the day your new service is energized. Preferred method of PSE installation is a work pit at the meter base i.e. a discontinuous conduit system.
- Disadvantages of a continuous conduit system:
  - » The length should be enough to ensure PSE's electrical cable can be pulled between the location of available power and the meter socket, and,
  - » Water can migrate and flow into the home if the available power source exists at a higher elevation than the location of the meter base.

**NOTE:** Contact CCS or your PSE project manager to initiate a cable pulling review.

**Figure 9** Example of continuous conduit in underground electric service

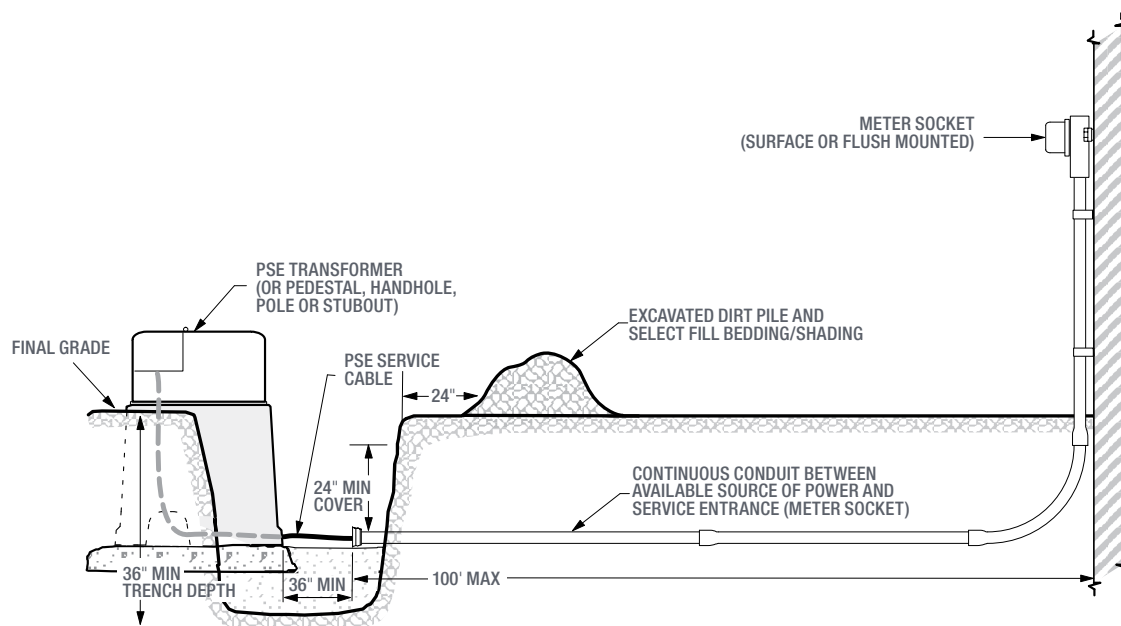

### When to choose continuous conduit

Choose to install a continuous conduit system for your electrical service if:

- At a distance where the cable pulling is easy without a pull rope. Contact CCS or your PSE project manager to initiate a cable pulling review.
- The sum total of the degrees of bends in the conduit run (including the bend required at the bottom of the meter base riser) does not exceed 180° with minimum radius of bend is 24 inches.
- The elevation at the location of available power is less than the elevation of your meter socket (i.e., your meter socket is uphill from the location of available power).

**NOTE:** By choosing to install a continuous conduit system, the customer assumes responsibility for recognizing potential surface and sub-grade water flows that may create an entry of water into the customer's electrical equipment. PSE is not responsible for damage caused by water entering a customer's meter base or equipment.

**Figure 10** Example of discontinuous conduit in underground electric service

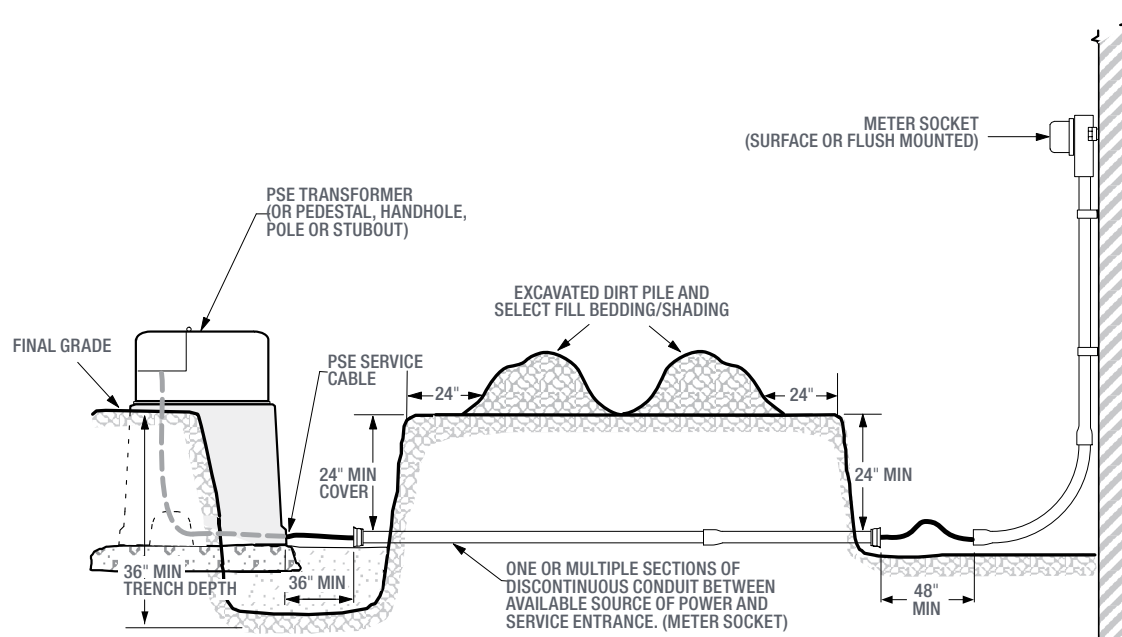

**When to choose discontinuous conduit**

Choose to install a discontinuous conduit system for your electrical service if:

- The sum total of the degrees of bends in the conduit run (including the bend required at the bottom of the meter base riser) exceeds 180° requiring additional work pits for cable pulling.
- The elevation at the location of available power is greater than the elevation of your meter socket (i.e., your meter socket is downhill from the location of available power).

A table for selecting the required conduit size is provided in the **Electric Underground Service Installation Requirements (Form 6080)**.

Puget Sound Energy (PSE) does not prefer continuous conduit system.

Contact CCS at **1-888-321-7779** if you have questions on whether to install continuous or discontinuous conduit for your underground electric service.

---

## Service entrance equipment

Determine the meter base/socket location, the service line route, and the size of the service you want (for example, 200 A), before you begin installing your service entrance equipment.

### Installation requirements

- Service entrance equipment can be installed either flush-mounted or surface-mounted (see Figure 11).
- Install the meter base/socket so that the top of the meter will be between 4 and 6 feet above finished grade with a 5 foot height being ideal.
- The service entrance conduit has a maximum of one 45° or 90° degree bend with a minimum 24-inch radius.
- Do not install “LB” joints, conduits, or devices that allow access to the service conductor in the riser ahead of the meter.
- A current transformer (CT) enclosure, if required, must be mounted on the outside of the structure it serves.

**NOTE:** Service entrance equipment for a 401–800 A installation is shown in Figure 12.

### Service entrance conduit size

The **Electric Underground Service Installation Requirements** ([Form 6080](#)) illustrates the service entrance conduit size requirements in detail.

**Figure 11** Two types of meter bases/sockets for permanent underground service, home built on permanent foundation

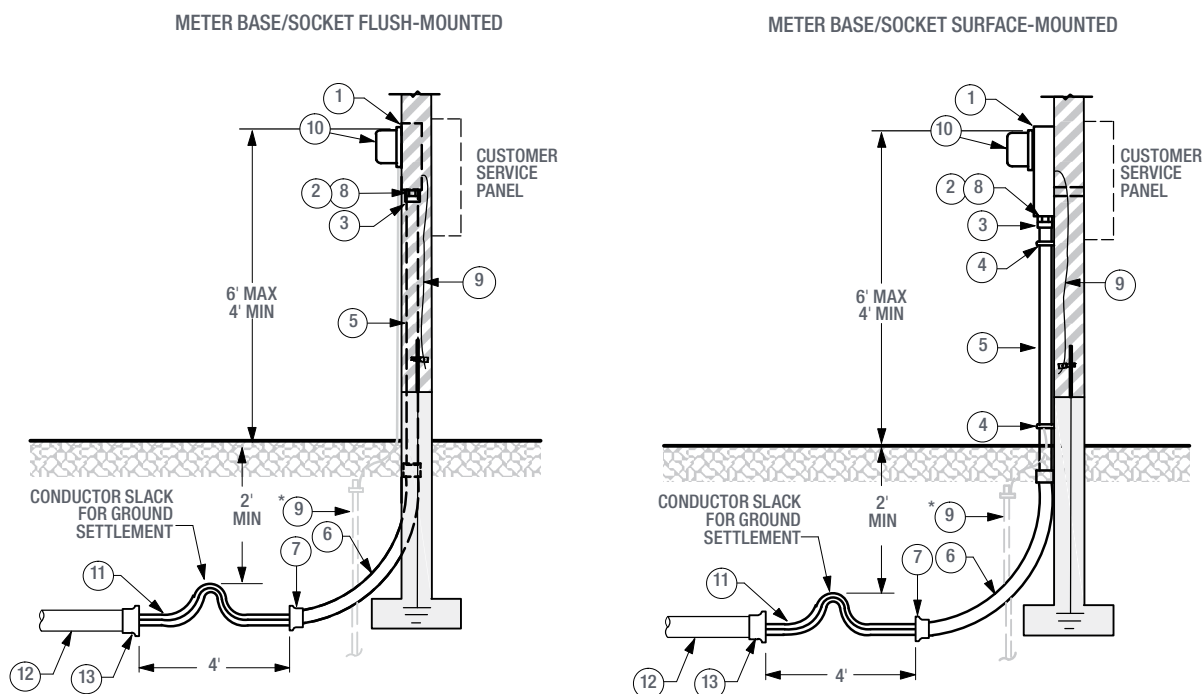

**NOTE:** Conductor slack shall be left at the base of the service entrance for ground settlement to relieve tension on meter connections.

**NOTE:** Total distance of raceway within the building to the customer's overcurrent protection shall not exceed 15 ft (WAC 296-46B-230.070).

\* Optional grounding electrode(s) for structures without permanent foundation.

\*\* Schedule 40 PVC or rigid-steel conduit may not be allowed on **flush-mount** installations. Check with local jurisdictional codes before installation.

Items owned and installed by customer	
1	Meter base/socket
2	Insulating busing
3	Terminal adapter or lock washer
4	Conduit strap (2)
5	Rigid steel conduit, Sch 40 or Sch 80 PVC **
6	Elbow, 45° or 90°, 24" min radius
7	Bell end
8	Lock washer
9	Ground electrode and wire in accordance with NEC/WAC

Items owned and installed by PSE	
10	Meter
11	Service line
PSE owned but customer purchased and installed	
12	Conduit (required in residential plats)
13	Bell end

**Figure 12** 401–800 A service entrance equipment, home built on permanent foundation

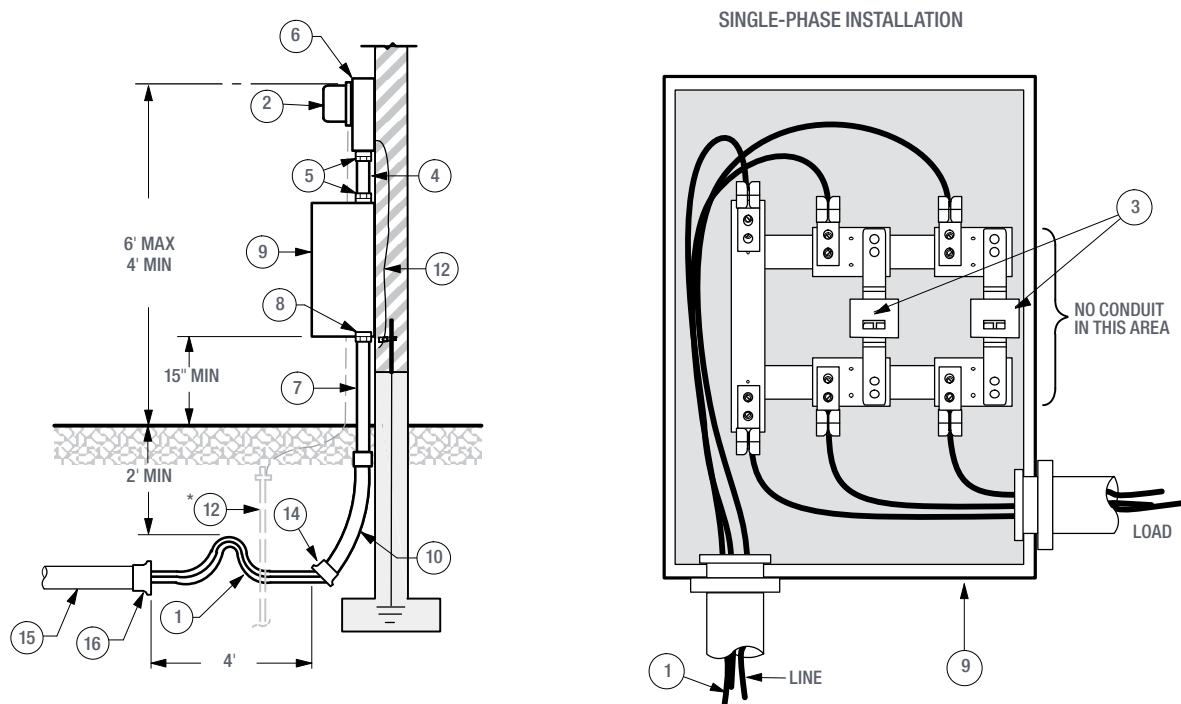

**NOTE:** Total distance of raceway within the building to the customer's overcurrent protection shall not exceed 15 ft (WAC 296-46B-230.070).

\* Optional grounding electrode(s) for structures without permanent foundation.

\*\* Schedule 40 PVC or rigid-steel conduit may not be allowed on flush-mount installations. Check with local jurisdictional codes before installation.

Items owned and installed by customer	
4	Conduit (Sch 40 or Sch 80 PVC or steel or EMT), 1" single-phase, 1-1/4" three-phase
5	Insulating busing
6	Six terminal meter base/socket with test switch space
7	Rigid steel conduit, Sch 40 or Sch 80 PVC **
8	Insulating bushing
9	Current transformer enclosure (outside or in electric room)
10	45° or 90° bend - rigid steel, Sch 40 or Sch 80 PVC
11	Line and load side connectors for service conductors (2-bolt lugs)
12	Ground electrode and wire in accordance with NEC/WAC *
13	Current transformer mounting bracket
14	Bell end

Items owned and installed by PSE	
1	Service conductors (residential only)
2	Meter
3	Current transformer with meter circuit wiring
PSE owned but customer purchased and installed	
15	Conduit (required in residential plats)
16	Bell end

---

## Permanent underground service for manufactured homes, 0–200 A

### Service equipment installation

If you are installing an underground service to your manufactured home, your service equipment can be installed one of two ways:

- On a customer-owned pedestal or meter post (see Figure 13).
- On the manufactured home, if both of the following conditions are met:
  - » The manufacturer installed the service equipment at the time your home was built.
  - » The service equipment meets the meter base/socket requirements listed below.

### Meter base/socket requirements

Meter base/sockets installed on manufactured homes must:

- Be located on an outside wall of your home.
- Be located on the front one-third of your home closest to normal drivable public access. Refer to Meter Locations and Clearances on Page 2 of the **Electric Underground Service Installation Requirements (Form 6080)** for more information.
- Be between 4 and 6 feet above finished grade.
- Meet PSE's service entrance conduit size requirements.
- Not be in a walkway or breezeway.
- Not be in an area that is subject to being fenced.

**NOTE:** Meter bases/sockets not installed on the manufactured home must meet the requirements of NEC 550.32(B).

**Figure 13** Permanent underground service for manufactured homes, 0–200 A

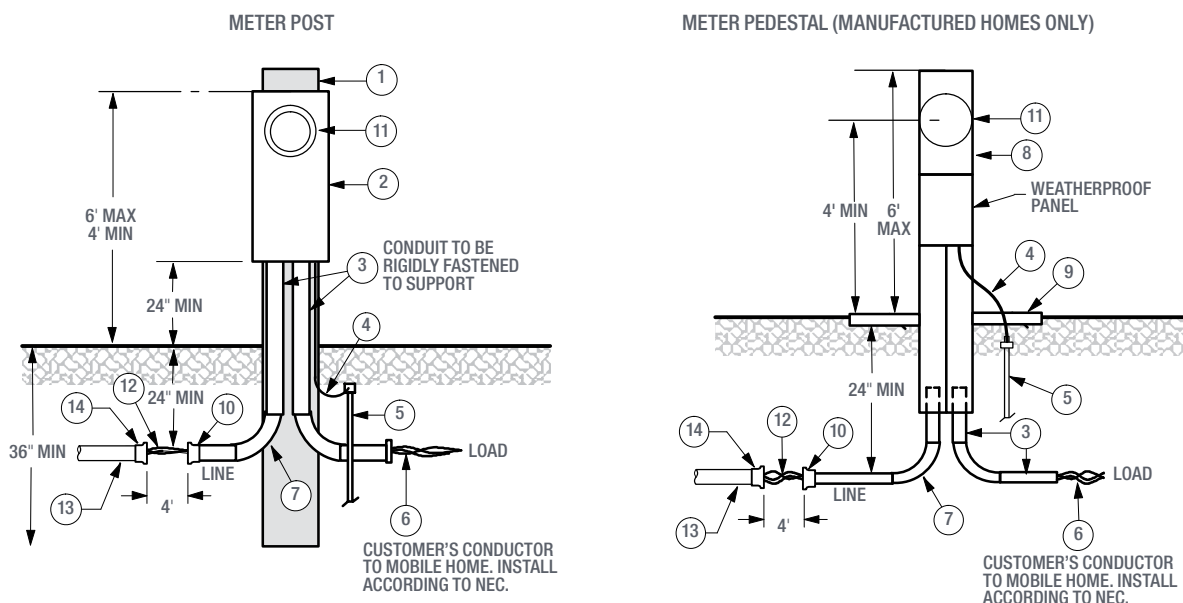

Items owned and installed by customer	
1	6" x 6" x 8" min fully pressure-treated post
2	Service entrance equipment
3	Service conduit as specified in Table 7
4	Ground wire, in accordance with NEC/WAC
5	Ground rod(s), in accordance with NEC/WAC
6	Service conductor to building/residence
7	Elbow, 45° or 90° bend, 24" min radius
8	Factory-built metal meter pedestal (manufactured homes only)
9	36" x 36" x 3" min concrete stabilizer pad
10	Bell end

Items owned and installed by PSE	
11	Meter
12	PSE service line
PSE owned but customer purchased and installed	
13	Conduit (required in residential plats)
14	Bell end

## Remote metering (meter loop) for underground residential services

### What is remote metering?

Normally, a meter base/socket and associated devices (current transformers, etc.) are attached to a permanent fixed structure that contains the load being served (such as a house). If the metering equipment is not attached to the permanent structure, it is called “remote metering.” In this case, the conductors that run from the meter to your house are installed, owned, and maintained by you.

### Requirements for residential remote metering, 200 A or less

Remote metering shall be mounted on a structure or meter post. It is your responsibility to purchase, install, and maintain this equipment. The required metering cabinet and supporting structure are shown in Figure 14.

Meter bases/sockets shall be permanently labeled to indicate the address they serve. PSE requires engraved phenolic nameplates or adhesive die-cut labels that are at least 1 inch high. Service will not be established until marking is complete.

**NOTE:** Felt-tip pens and label maker tape are not considered permanent marking.

**Figure 14** Remote metering for underground residential services on meter post

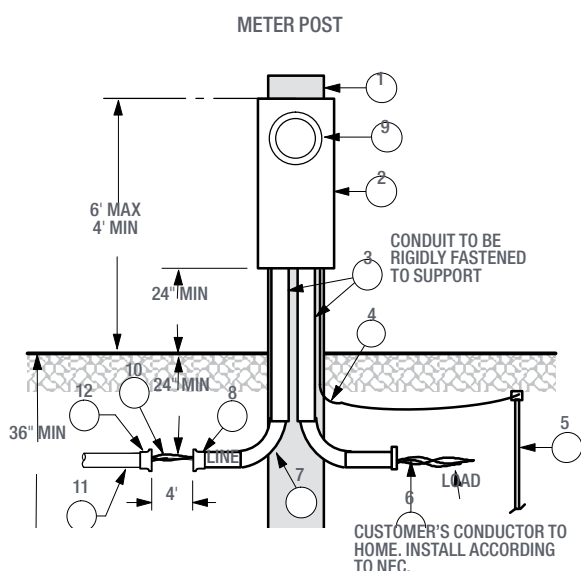

#### Items owned and installed by customer

- 1 6" x 6" x 8' min fully pressure-treated post, mason block, or concrete
- 2 Service entrance equipment
- 3 Service conduit as specified in Table 7
- 4 Ground wire, in accordance with NEC/WAC
- 5 Ground rod(s), in accordance with NEC/WAC
- 6 Service conductor to building/residence
- 7 Elbow, 45° or 90° bend, 24" min radius
- 8 Bell end

#### Items owned and installed by PSE

- 9 Meter
- 10 PSE service line

#### PSE owned but customer provided and installed

- 11 Conduit (required in residential plats)
- 12 Bell end

**NOTE:** For 320-amp service, use galvanized steel pipe for the post.

### 320 A, 400 A, and larger panels

Remote meter installations that require current transformers shall be mounted on permanent support structures that are made of galvanized steel pipe with unistrut cross-braces, concrete, or masonry blocks (see Figure 15). Support structures made of wood (treated or not) are unacceptable.

The customer shall provide a 3-foot x 3-foot x 3-inch-thick concrete pad surrounding the meter or holes 2 feet deep that are filled with concrete to anchor the structure.

Meter bases/sockets shall be **permanently labeled** to indicate the address they serve. PSE requires engraved **phenolic nameplates** or adhesive die-cut labels at least 1-inch high. Service will not be established until marking is complete.

**NOTE: Felt-tip pens and label maker tape are not considered permanent marking.**

Other requirements specified in this handbook for meter bases/sockets and current transformer (CT) enclosures apply.

**Figure 15** Remote metering for underground residential services on meter pad

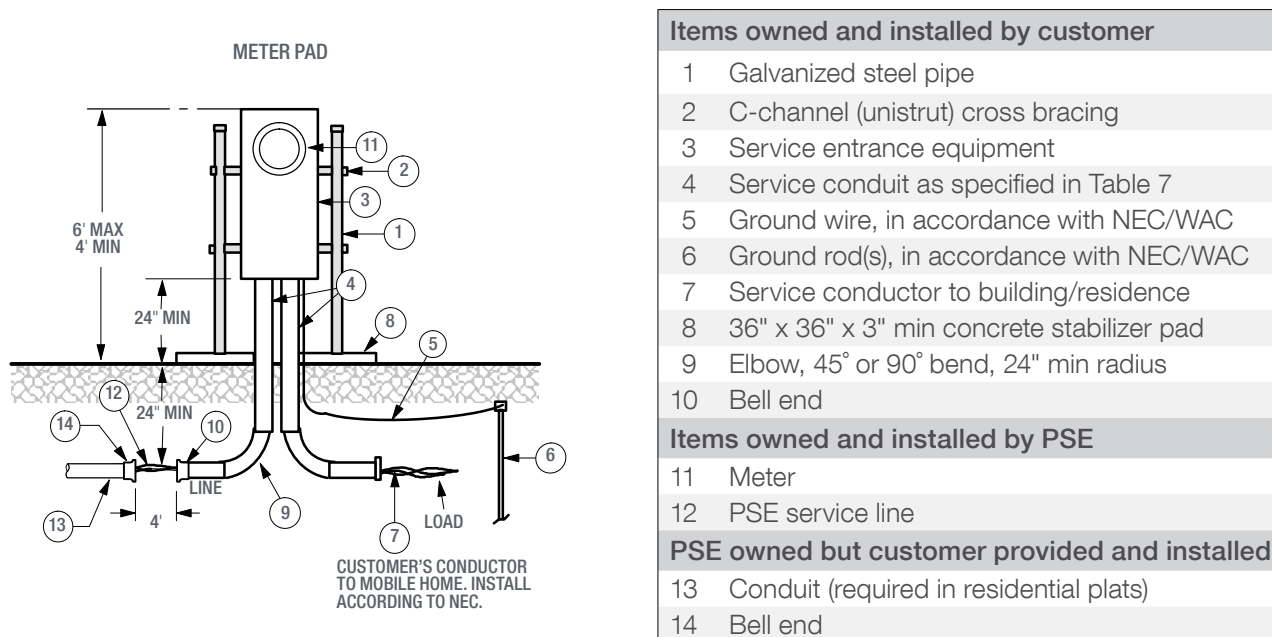

### Remote services greater than 800 A

Remote services 800 A or greater require EUSERC outdoor switchgear. Ask your CCS Representative for more information.

### Meter post and pedestal locations

Remote metering must be:

- Accessible for reading and maintenance during normal business hours.
- Not be in a walkway or breezeway.
- Not be in an area that is subject to being fenced or enclosed.
- Safe parking must be located within 50 feet of the meter.

**NOTE:** When installed close to PSE's transformer, all metering equipment must be a minimum of 3 feet from the transformer and not installed in front of the transformer.

# Chapter 3

## Permanent overhead service

---

### Steps to a successful overhead service installation

The following checklist will assist you in preparing for the installation of an overhead service (see Figure 16). After you have completed these items, PSE can install the overhead service line and meter.

- Check for any local ordinances/covenants that prevent you from obtaining an overhead service.
- Call PSE to set up an account and submit an order. Allow adequate time for possible engineering, right-of-way permits, and easement review.
- Obtain an electrical work permit.
- Complete Electric Service Application Single-Family Residential 100E. All forms can be downloaded at [pse.com/construction-services](https://pse.com/construction-services).
- Supply recently approved site drawings including septic, drain field location, wet and dry utility locations and load information to your PSE Customer Construction Services (CCS) Representative.
- Call CCS to find out where your service line will originate.
- Determine an acceptable location for your meter base/socket.
- Provide a path clear of obstructions between PSE's service pole and your service mast. Remove any trees/tree branches, bushes and any vegetation within 3 feet around the service conductor path.
- Provide the location of any domestic or community water well on your property included in the site plan as well.
- Install the required service entrance equipment.
- Install the service entrance conductors (leave a minimum of 18 inches exposed at the weatherhead).
- Verify that the service mast height requirements have been met (see Figure 16).
- Provide payment for any preconstruction costs determined by CCS.
- Have the city or state inspect and approve your installation.
- Call CCS at **1-888-321-7779** to have your service installed and energized.

## Selecting a meter base/socket location

After CCS determines which pole the service line will come from, you can determine the location of your meter base/socket.

Your meter base/socket must be located outside and on the front one-third of your structure closest to normal drivable public access. Refer to Chapter 5 in this handbook for detailed meter location criteria.

Consider the type of terrain the line will cross when choosing a meter base/socket location. PSE strongly suggests avoiding service line routes that cross a driveway. Service lines that cross driveways can be hit by vehicles, which can cause damage to the service equipment and even to your home.

**Figure 16** Typical overhead service installation

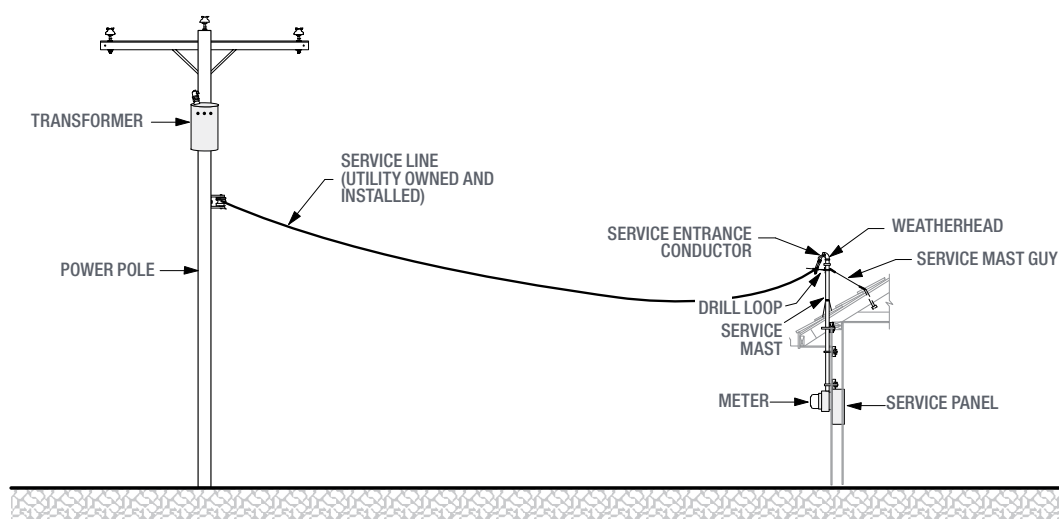

## Clearance requirements

### Service line ground clearance

The National Electric Safety Code (NESC) establishes minimum clearance requirements to maintain safe height requirements for electrical conductors over various terrain (see Figure 17).

The NESC requires the lowest point of a service conductor to be at least **12 feet** above the ground. The bottom of the drip loop must be a minimum of **10 feet** above the ground.

### Maintenance of your service around trees

If the service line will pass through any trees, you are required to prune those trees to provide a clear path for the service line. You are also responsible for regular tree pruning, and if necessary, tree removal to keep the path clear.

### Attachment of service conductor

It is not your responsibility to string the conductor, but you are required to provide a point of attachment at your service mast that will allow PSE to install the conductor and maintain the required clearances.

If you need further details, please contact the state or local electrical inspector for your area.

Figure 17 Minimum overhead service line vertical clearances from ground level

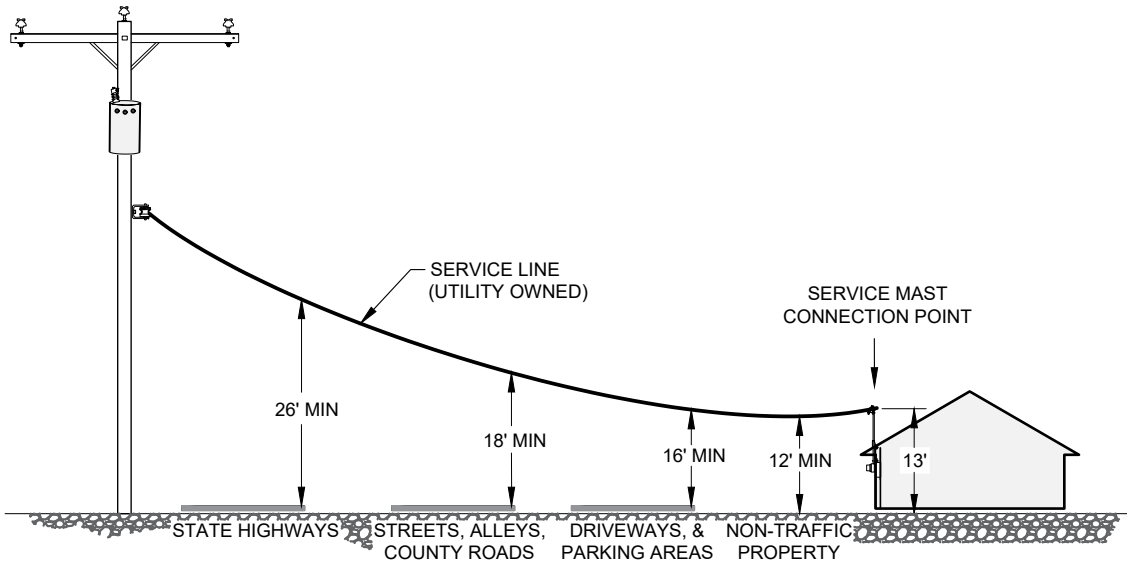

**Minimum clearances from structures, building openings, and gas meters**

- A minimum clearance of 3 feet is required between electric service lines and windows, doors, porches, fire escapes, or similar openings.
- A minimum radial clearance of 3 feet is required between electric service equipment and the natural gas meter pressure relief vent (see Figure 18).
- Service lines passing over the roof of another structure (but not attached to that structure) must maintain the minimum clearances (see Figure 18).
- Service lines passing over a deck must maintain a minimum clearance of 11 feet (see Figure 18).

Figure 18 Minimum clearances over other structures

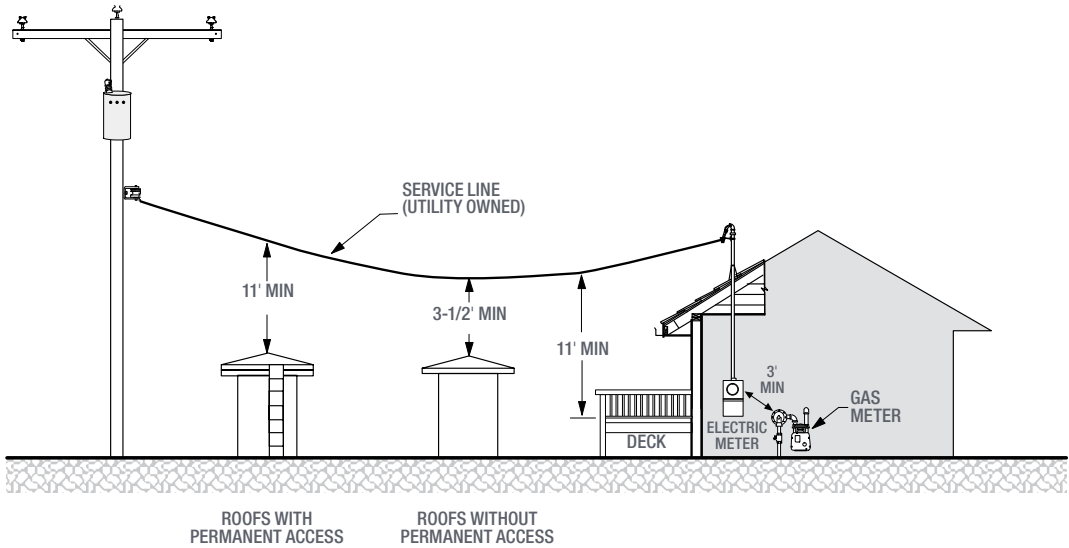

### Intermediate service pole

When the length of an overhead service line exceeds 125 feet or the clearances shown in Figure 18 cannot be achieved, an intermediate service pole **may** be required to maintain safe ground clearance (see Figure 19) for the wire and to relieve excessive tension at the service mast. Contact your PSE project manager to initiate a review.

This intermediate service pole is set and owned by PSE and the cost is in addition to the service line costs. Please contact CCS for installations that may require an intermediate service pole to determine additional costs.

**Figure 19** Intermediate service pole location

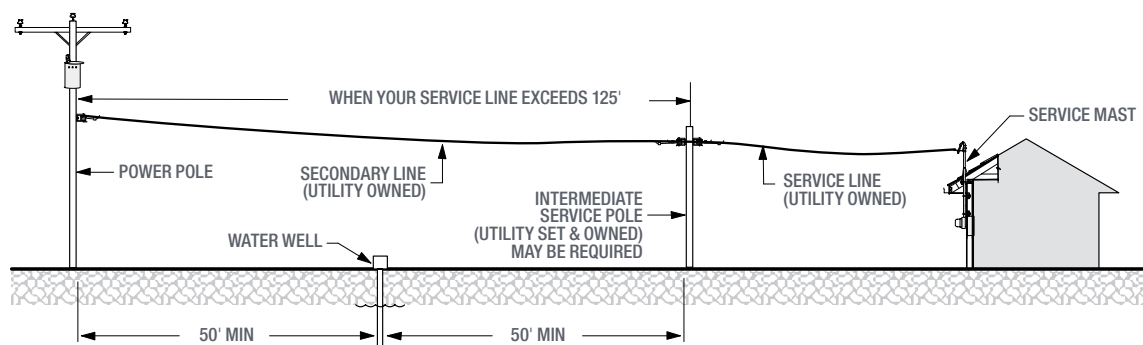

### Service mast

A service mast is a rigid steel conduit that runs vertically from the top of your meter base/socket up through your roof. It contains your service entrance conductors and typically supports one end of your service line. Service masts are necessary when installing an overhead service and are installed by you or your electrical contractor.

#### Service mast requirements

The service requirements for the installation of the service mast are located in the National Electric Code (NEC). Some of the more common methods are included in this section (see Figures 20 and 21).

#### Height requirements

The service bracket (the point of connection with PSE's service wire at the top of your service mast) must be at least 13 feet above final grade or terrain so that the minimum clearances over your property can be maintained. Additional height may be required depending on the location and type of structure or terrain that your service line passes over.

The NEC also requires that your service mast maintain minimum clearances above your roof (see Figure 20). The clearance required depends on the slope of your roof, and whether or not your service line is attached to the structure.

For other options and details refer to the NEC. Your CCS Representative can assist you with determining the proper mast height.

Figure 20 Unguyed service masts

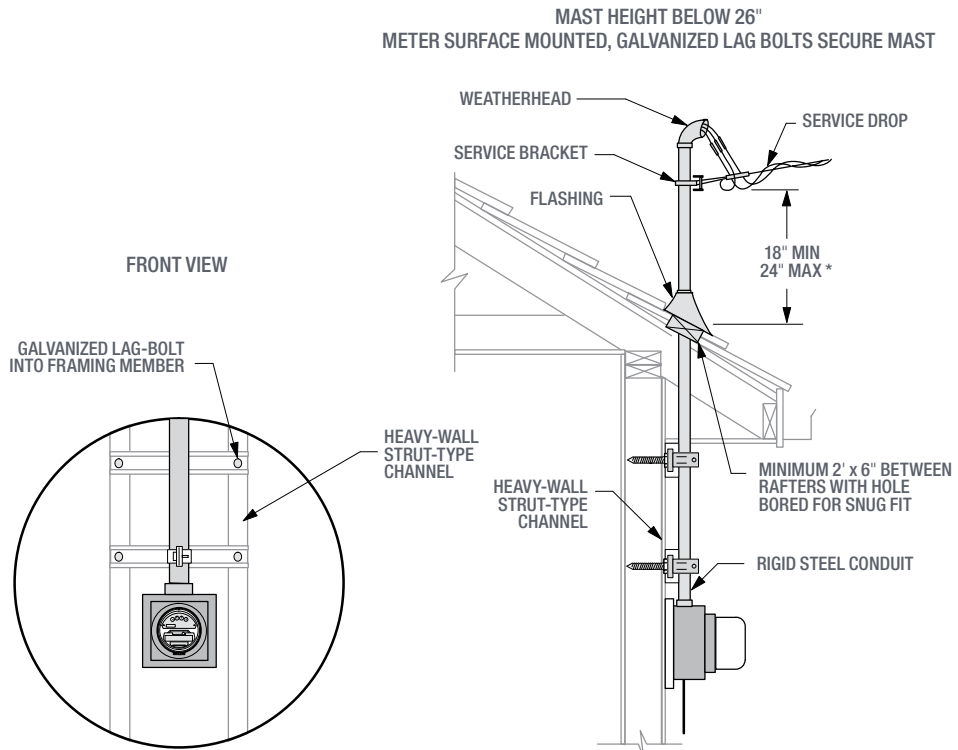
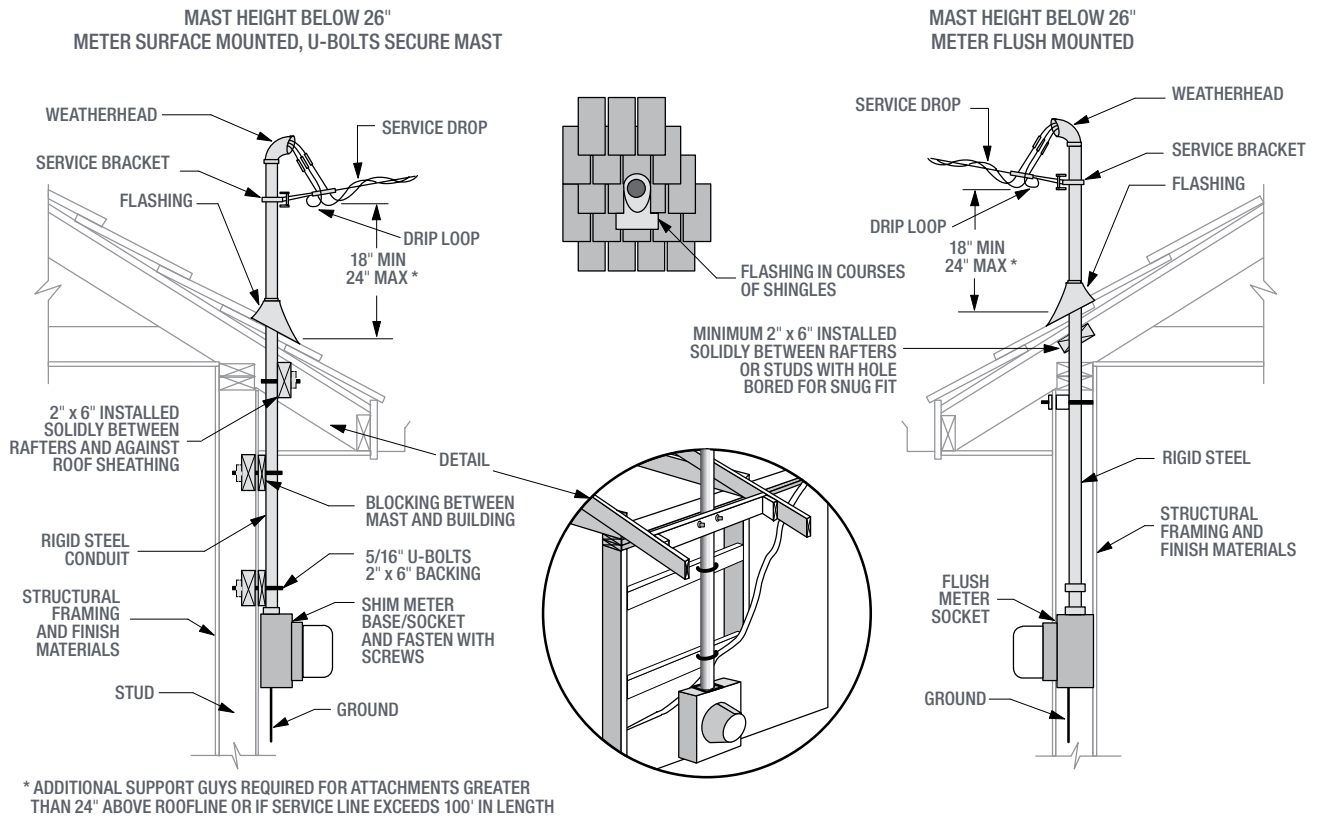
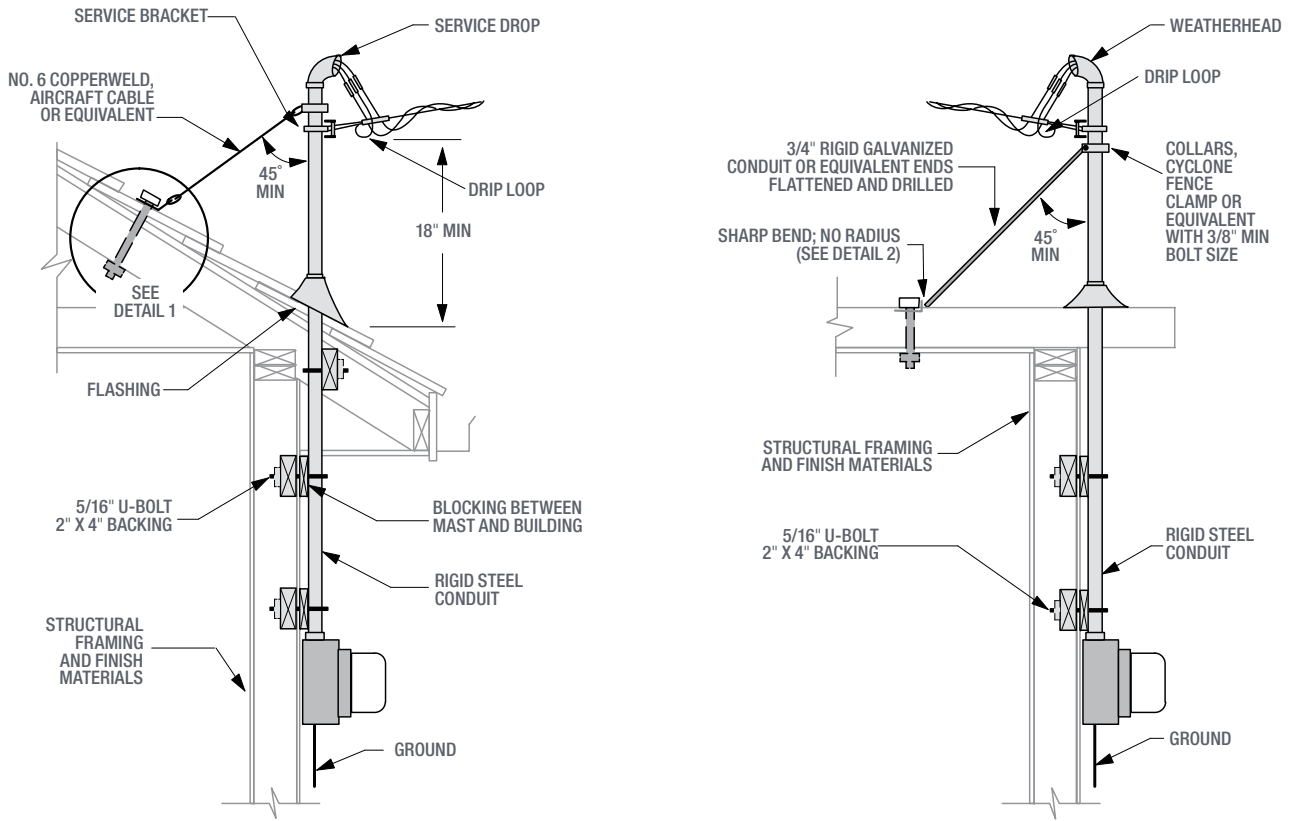
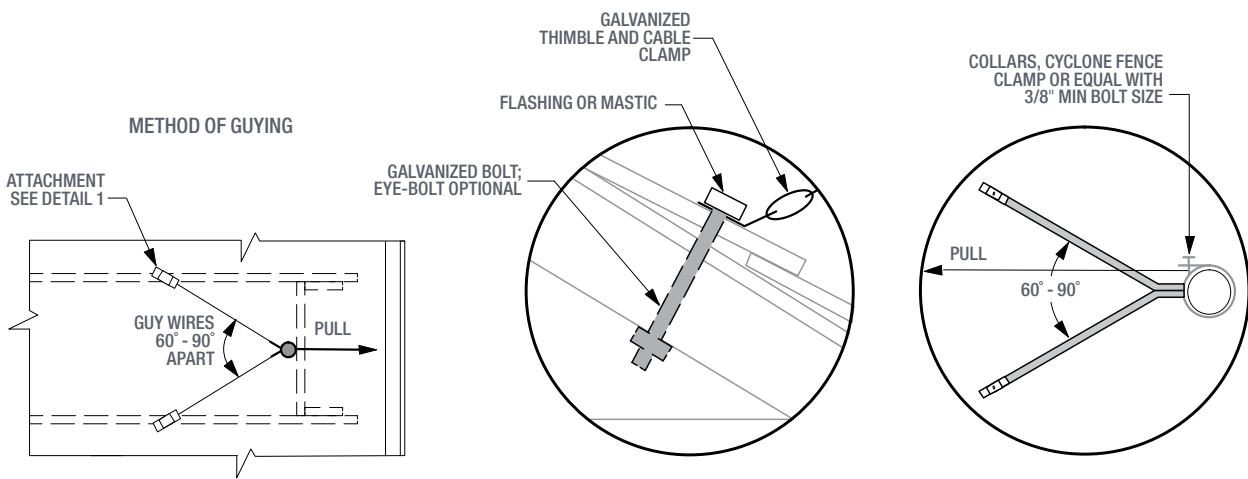

Figure 21 Guyed service masts



DETAIL 1

DETAIL 2



**Additional mast supports (guy or brace)**

Additional mast supports, typically a guy or a brace, are required for any service line if:

- The service line is over 100 feet long; or,
- The point of attachment is more than 24 inches above your roof (see Figure 21).

Guys and braces are installed to prevent the weight of the service line from pulling your service mast away from your home or damaging your roof.

Further information regarding guying and bracing service masts is available in the NEC.

**Screw-in service knobs**

For new or altered overhead service lines, you must provide a substantial point of attachment that meets NEC requirements. Older type screw-in service knobs attached to the home's wall are often inadequate to support modern triplexed service lines. PSE may prohibit use of service knobs if deemed inadequate.

---

## Service entrance equipment installation requirements

After you have determined the meter base/socket location, the service route, the height of your service mast, and the size of your service (200 A, 400 A, etc.); you are ready to begin installing your service entrance equipment.

Once you have installed your meter base/socket and mast you are ready to provide and install your service entrance conductor. The service entrance conductor is the wire that is connected to the top lugs in your meter base/socket and runs up through the service mast.

The service entrance conductors must be sized according to the NEC and to the rating of your meter base/socket. When installing the wire, leave at least 18 inches of it exposed at the end of the weatherhead to allow PSE to connect your service line to it. When you install your meter base/socket, make sure the top of the meter will be between 4 and 6 feet above finished ground level.

If you have any questions regarding the installation of your service equipment, we suggest that you refer to the NEC, call the inspecting agency for your area, or contact an electrical contractor.

---

## Manufactured homes

If you are installing an overhead service to a manufactured home, our service equipment can be installed one of two ways:

1. On a customer-owned meter pole, or,
2. On the manufactured home, if both of these conditions are met:
  - a. The manufacturer installed the service equipment at the time the home was built, and
  - b. The service equipment meets the meter base/socket requirements listed below.

### Meter base/ socket installation requirements for manufactured homes

Meter base/sockets installed on manufactured homes must be:

- Located on an outside wall of your home and accessible for reading and testing.
- Located on the front one-third of your home closest to normal public access.
- Between 4 and 6 feet above finished grade.

**NOTE:** Do not locate the meter base/socket in an area that is subject to being fenced.

---

## Customer-owned meter pole

### Meter pole requirements

If a meter pole is required for the project, it is the customer's responsibility to purchase and install it. The meter pole must meet the following requirements:

- Be sound, round, or square, and reasonably straight and made of wood (commonly cedar or Douglas fir).
- Fully pressure treated. Verification from a PSE representative is required before installing the pole.
- Minimum nominal diameter of 5-1/2 inches at the top (see the Service length section for the minimum pole size requirement).
- Class 6 or better.
- 35 feet long minimum. **Exception:** With prior approval from a PSE representative, a meter pole of 20, 25, or 30 feet in length may be used (see the Minimum pole length requirement section) if the minimum conductor-to-ground clearances can be met (see Figure 17 for requirements).
- Butt gain cut 12 feet from the bottom of the pole (2-inch by 1/2-inch cut into the face of the pole), or a have a manufacturer's tag attached at 12 feet from the bottom of the pole. Nailing a washer to the pole at this location is acceptable as an alternative to having the gain pre-marked at the factory.

Figure 22

Butt gain

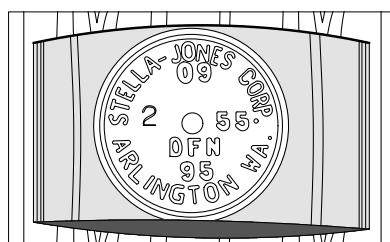

**Meter pole locations**

Meter poles shall be:

- Accessible for reading and testing the meter.
- Located in a maximum distance of 150 feet from PSE's utility pole.
- In an area that does not cross adjoining properties without obtaining easements.
- Installed within 30 feet of the commercial building.
- Approved by a PSE representative.

**Guying**

- A guy is required on all meter poles where the distance between PSE's pole and the meter pole is greater than 70 feet or the span crosses a public road and where the native soil is sand, clay, gumbo, peat, highly organic, swamp, marsh, or any uncompacted or uncompactible material.
- A push brace or pole key brace may be used if guy space is unavailable.
- PSE engineering shall verify spans and guying for non-round poles.

A meter pole installation is shown in Figure 23.

**NOTE:** Multiple meters serving separate properties are not allowed on a single-meter pole.

If you have any questions, contact your CCS Representative for further assistance.

**Setting**

- Meter poles shall be set at a minimum depth of 10% of the pole's total length plus 2 feet.
- If soil conditions are poor, crushed rock can be used as a substitute for backfill.
- The customer shall provide evidence of buried depth of pole to PSE by adding a butt-gain-type marker, such as nailing a washer to the pole at the location required.
- A PSE representative shall be able to see the butt gain upon field inspection.
- A photo or means of evidence that the "gain" was installed on the pole at the correct location is the customer's responsibility. As an alternative, the customer can schedule an appointment with a PSE representative at the time to install the pole to allow PSE to inspect the correct depth of installation. Another alternative is for the customer to take a photo of the depth of bury with a measuring tape and provide it to PSE as evidence of compliance.

**Service length**

- Round and square timbers for a service length of less than 100 feet require a continuous, one-piece 6-inch by 8-inch minimum timber.
- Round and square poles with service length greater than 100 feet require a continuous, one-piece 8-inch by 8-inch minimum timber.
- A PSE representative shall approve a service drop length exceeding 100 feet.
- All pole-mounted service equipment shall be installed on a standoff brackets to facilitate climbing.

**Minimum pole length requirement**

- If the meter pole is within 50 feet of a PSE power pole and the service conductor does not pass over a driveway or parking area, then:
  - » The minimum pole length of 20 feet is allowed with PSE approval.
- If the meter pole is within 50 feet of a PSE power pole and the service conductor passes over a driveway or parking area; **or**,
- If the meter pole is between 50 feet to 100 feet of a PSE power pole and the service conductor does not pass over a driveway or parking area, then:
  - » The minimum pole length of 25 feet is allowed with PSE approval.
- If the meter pole is between 50 feet to 100 feet of a PSE power pole and the service conductor passes over a driveway or parking area; **or**,
- If the meter pole is between 101 feet to 150 feet of a PSE power pole and the service conductor does not pass over a driveway or parking area, then:
  - » The minimum pole length of 30 feet is allowed with PSE approval.
- If the meter pole is between 50 feet and 100 feet of a PSE power pole and the service conductor crosses over a city or county road or state highway; **or**,
- If the meter pole is between 101 feet and 150 feet of a PSE power pole and the service conductor passes over a driveway or parking area; **or**,
- If the meter pole is between 101 feet and 150 feet of a PSE power pole and the service conductor crosses over a city or county road or state highway, then:
  - » The minimum pole length is 35 feet.

Figure 23 Permanent overhead meter pole installation

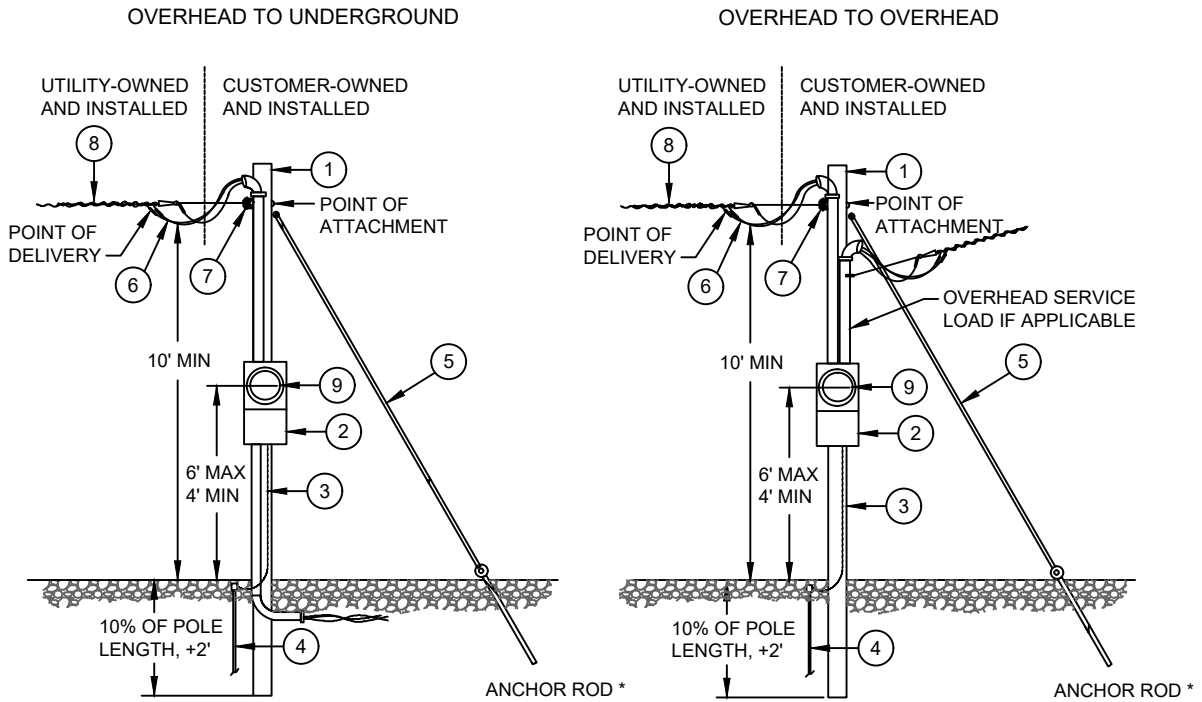

\* ANCHORS SHOULD BE EITHER SCREW TYPE OR CROSS-PLATE TYPE.

Items owned and installed by customer	
1	Customer-owned meter pole
2	Meter socket
3	Ground wire, in accordance with NEC/WAC
4	Ground rod(s), in accordance with NEC/WAC
5	Down guy, 5/16" minimum diameter noncorrosive stranded steel wire required for services over 70 ft from PSE pole. Push brace or pole key brace may be substituted for down guy.
6	Service entrance conductors - 18" out of weatherhead
7	Insulated clevis

Items owned and installed by PSE	
8	Service line
9	Meter

# Chapter 4

## Primary line extensions

---

If your new residence is not located close to existing primary electrical facilities, a primary line extension is required to place a transformer close to your structure. Primary line extensions are typically underground facilities.

## Customer responsibility

---

PSE's Electric Tariff G, Schedule 85 requires customers to provide the trenching, excavation for vaults and backfill in accordance with PSE standards and work sketch, or contract with PSE to provide this work at its estimated cost.

If you require a primary line extension, submit Electric Service Application Single-Family Residential 100E. All forms can be downloaded at [pse.com/construction-services](https://pse.com/construction-services).

## Inspection/Coordination

---

PSE shall assign a Project Manager to oversee the trench location, equipment placement/installation, and backfilling.

- Work shall be subject to the inspection and satisfaction of PSE.
- No work shall be backfilled, covered, or concealed until it has been inspected and approved by the inspector.

## Site preparation

---

The following site requirements must be met before the installation can begin.

- The trench route shall be clear of spoils, construction materials, and any other obstacles.
- The site shall be at final grade or acceptable subgrade in the area of construction.
- The front property line shall be surveyed and staked.

## Customer-provided trench

### Trench width

The minimum trench width is 18 inches. The excavator may need to increase the trench width depending on the other conduits/lines being installed in the trench.

When increasing the trench width, remember to allow adequate horizontal separation between PSE's electrical conduits/cables, gas lines, and other utility-owned conduits and lines in the trench (see Figure 24).

Customer-owned facilities may not be in the same trench with PSE-owned gas lines.

PSE will allow customer-owned facilities within an electric power trench if the following minimum horizontal clearances from PSE electric facilities are maintained:

- 18 inches minimum for customer-owned tight-line sewer (not tile), storm drain lines, roof drain lines, natural gas line, propane gas line, fuel oil line, and water mains up to 6 inches.
- 12 inches minimum for water services, irrigation pipes, lighting, security and electric supply circuits, communication lines, closed-system roof drains/storm drains (not French drains), and culverts.

**NOTE:** When constrained by obstructions or clearances from other buried utility lines/facilities, the horizontal clearance between PSE power and communications may be reduced to 4 inches with mutual agreement from the participating communications providers. It is your responsibility to obtain agreement from participating communications providers for a reduced clearance when needed.

Figure 24 illustrates PSE's width and depth requirements for primary voltage cable residential line extension trenches on private property with and without a gas line present.

Figure 24

Conduit riser placement detail - top view (not to scale)

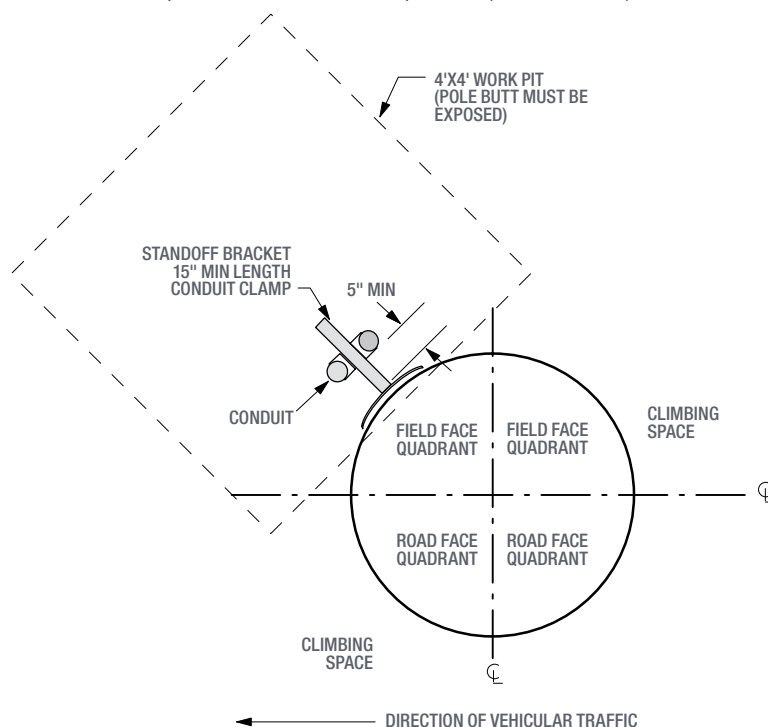

**NOTE:** Please see the **Gas and Electric Underground Service Installation Requirements (Form 3061)** for work pit details.

**Figure 25** Typical joint utility trench with primary voltage cable on your private property (cross-section view)

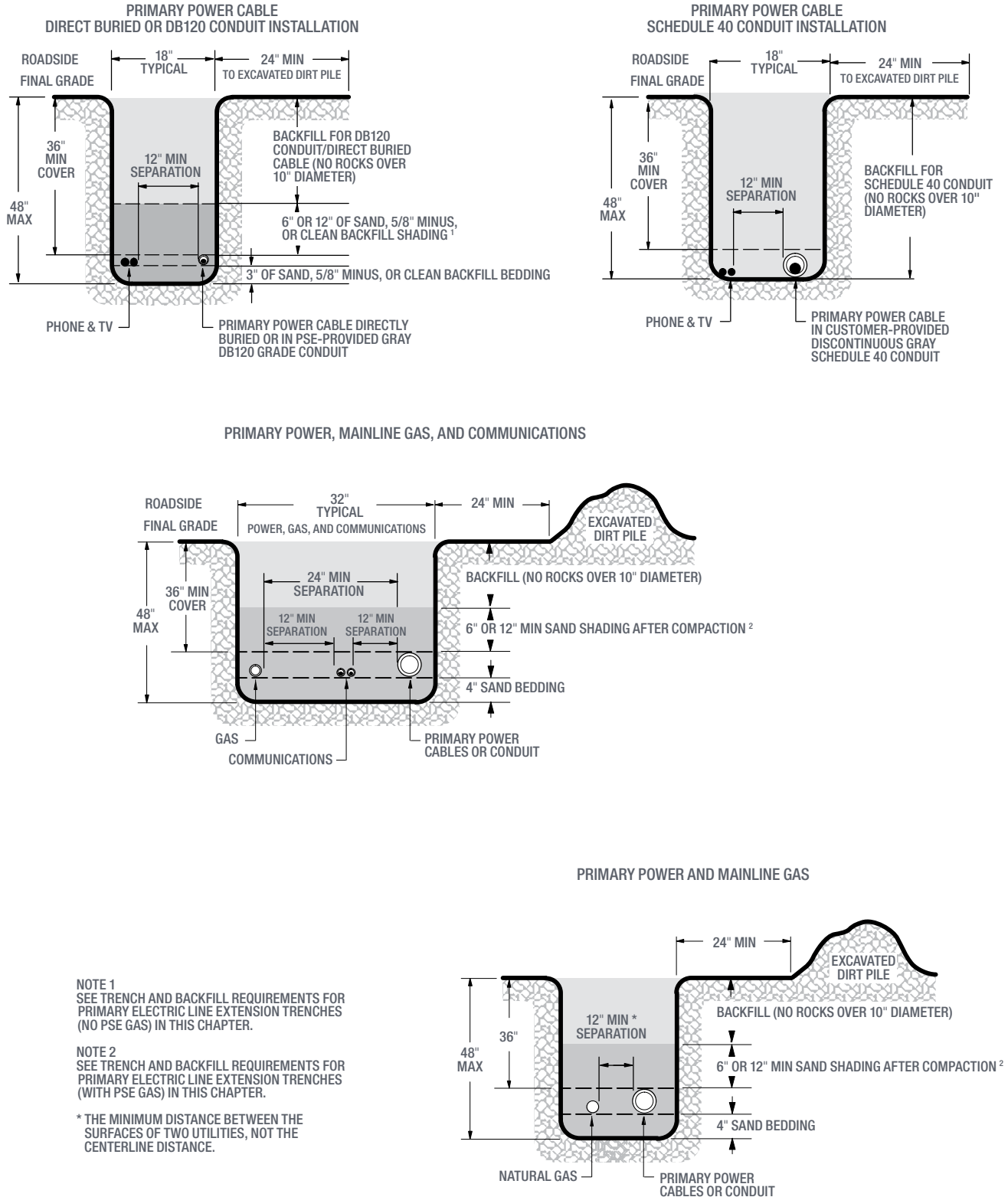

NOTE 1  
SEE TRENCH AND BACKFILL REQUIREMENTS FOR PRIMARY ELECTRIC LINE EXTENSION TRENCHES (NO PSE GAS) IN THIS CHAPTER.

NOTE 2  
SEE TRENCH AND BACKFILL REQUIREMENTS FOR PRIMARY ELECTRIC LINE EXTENSION TRENCHES (WITH PSE GAS) IN THIS CHAPTER.

\* THE MINIMUM DISTANCE BETWEEN THE SURFACES OF TWO UTILITIES, NOT THE CENTERLINE DISTANCE.

## Trench excavating requirements

The following requirements for the trench must be met before power conduits/cables will be installed.

- When trenching in right-of-way (ROW), the governing jurisdictions may require the entity performing the trenching to obtain a ROW permit. Additionally the entity performing the work will need to be licensed and bonded.
- Contact the governing jurisdiction to determine specific permitting requirements and the approximate turn around time from the permit application submittal date.
- For trench work provided by you within a public ROW or a PSE easement, PSE requires that you use a Washington State licensed and bonded contractor and complete and sign a PSE trenching agreement form.
- Trench work within a public right-of-way must meet the erosion and sediment control requirements of the local jurisdiction.

**NOTE:** Acquiring permits for excavation-related activity can take more than a month or longer depending on the amount of material being excavated, location of the excavation, and the jurisdiction issuing the permit. To avoid schedule delays, contact your PSE Project Manager for an estimated time frame to acquiring your permits.

- Provide a signed Excavation Requirements & Final Grade Certification document supplied by your Project Manager or PSE Representative.
- The trench shall be excavated according to the trench detail and PSE's work sketch.
- The trench shall be straight and the trench bottom shall be smooth, level, and free from obstructions, sharp objects, or rocks larger than 1/2 inch in diameter.
- Excavated or loose material shall be placed at least 2 feet from the field edge of the trench.
- Water shall be removed by pumping or draining following the erosion and sediment control requirements of the local jurisdiction.

**NOTE:** Trenches or vault excavations that are 4-feet-deep or greater require special sloping. Contact your PSE Project Manager for these requirements.

**Restrictions:** When PSE's project scope requires the manipulation of an existing primary cable or circuit, customers or third party contractors shall not uncover and expose existing buried primary voltage power lines or ducts in an energized state. PSE shall coordinate with the customer and service provider for the lines to be de-energized and grounded, or PSE shall provide qualified workers to perform exposure of energized buried lines. These restrictions apply to both direct-buried cables and cables in conduit.

### Trench and backfill requirements for primary electric line extension trenches (no PSE gas)

PSE will not energize its facilities until backfill is completed.

When PSE primary cables are directly buried, or installed in PSE-provided gray DB120 grade conduit, you are responsible for the following:

- Providing a minimum 3-inch bedding layer of sand, 5/8-inch minus, or clean backfill (with rocks or solid material no larger than 5/8 inch in diameter and no sharp objects) placed below cables/conduits.
- A 12-inch layer of the same shading material above the directly buried cables/conduits.
- If native backfill is completely free of foreign objects and rocks in excess of 8 inches in diameter, shading with sand, 5/8-inch minus, or clean backfill can be reduced to 6 inches.
- The remaining trench shall be backfilled with soil that is free of rocks larger than 10 inches in diameter and foreign objects.

When PSE primary cables are installed in gray Schedule 40 grade or better conduit, you are responsible for the following:

- Backfilling the trench with soil that is free of foreign objects and rocks larger than 10 inches in diameter. Bedding and shading of the conduit with sand, clean backfill or select fill as 5/8-inch minus crushed aggregate is not required.

### Trench and backfill requirements for primary electric line extension trenches (with PSE gas)

You must provide a 12-inch layer of sand above and a 4-inch layer of sand bedding below the utilities before backfilling (see Figure 25). If native backfill is completely free of foreign objects and rocks in excess of 8 inches in diameter, sand shading over utilities can be reduced to 6 inches after compaction.

You are responsible for the following:

- Completing backfill as soon as practical after facilities are placed and inspected.
- Carefully placing backfill to prevent damage or movement of the cables or conduit.
- Cost of damages to PSE facilities caused by improper backfill or compaction.
- Relocation costs due to change in grade or alignment.

**CAUTION:** Do not use a compactor directly over the power conduit(s) until at least 30 inches of backfill is in place so that the compactor will not damage the cables or conduit. Do not penetrate the soil deeper than 3 inches during compaction with a backhoe compactor.

---

## Vaults

PSE is responsible for furnishing and installing all primary vaults, secondary pedestals, and secondary handholes required for your electric service.

### Vault excavation procedure

1. Locate the vault according to PSE's work sketch drawing.
2. Determine a suitable place to put the spoils (at least 2 feet from the edge of the excavation).
3. Excavate so the vault is in correct alignment with the trench and so that conduits for primary voltage cables (if required) can be brought straight into the front half of the vault.
4. Dig a hole large enough to accommodate the transformer or junction box vault and allow for easy installation and compaction (see Figures 26 through 28).
5. Remove debris and level the bottom of the excavation.
6. Prepare the bottom of the excavation so that the vault will rest on solid undisturbed earth with a 6-inch base of crushed rock. This prevents vault settling.

**Figure 26** Minimum dimensions and excavation requirements for a single-phase padmount transformer vault

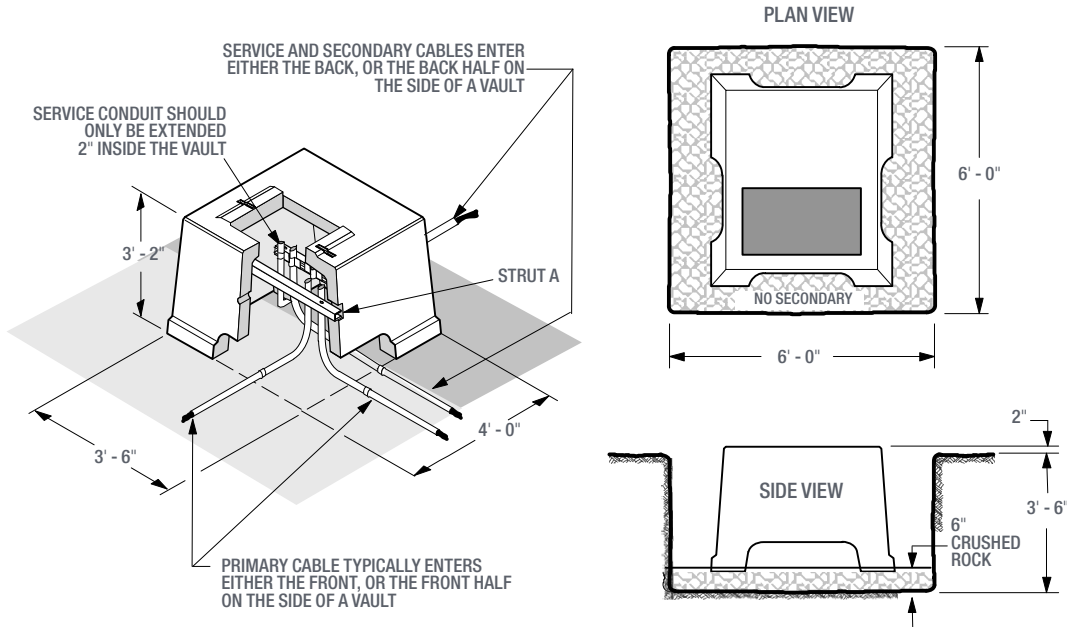

**Figure 27** Aboveground junction box vault excavation

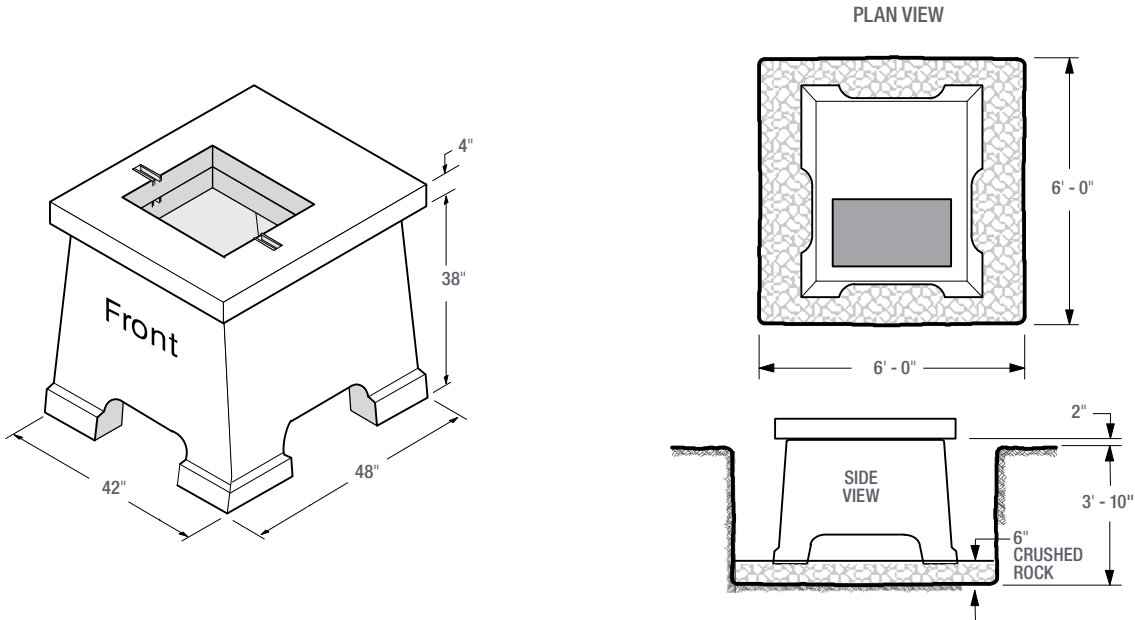

**NOTE:** Refer to Figure 26 for proper access points.

**Figure 28** Minimum dimensions of excavation requirements for small secondary handholes

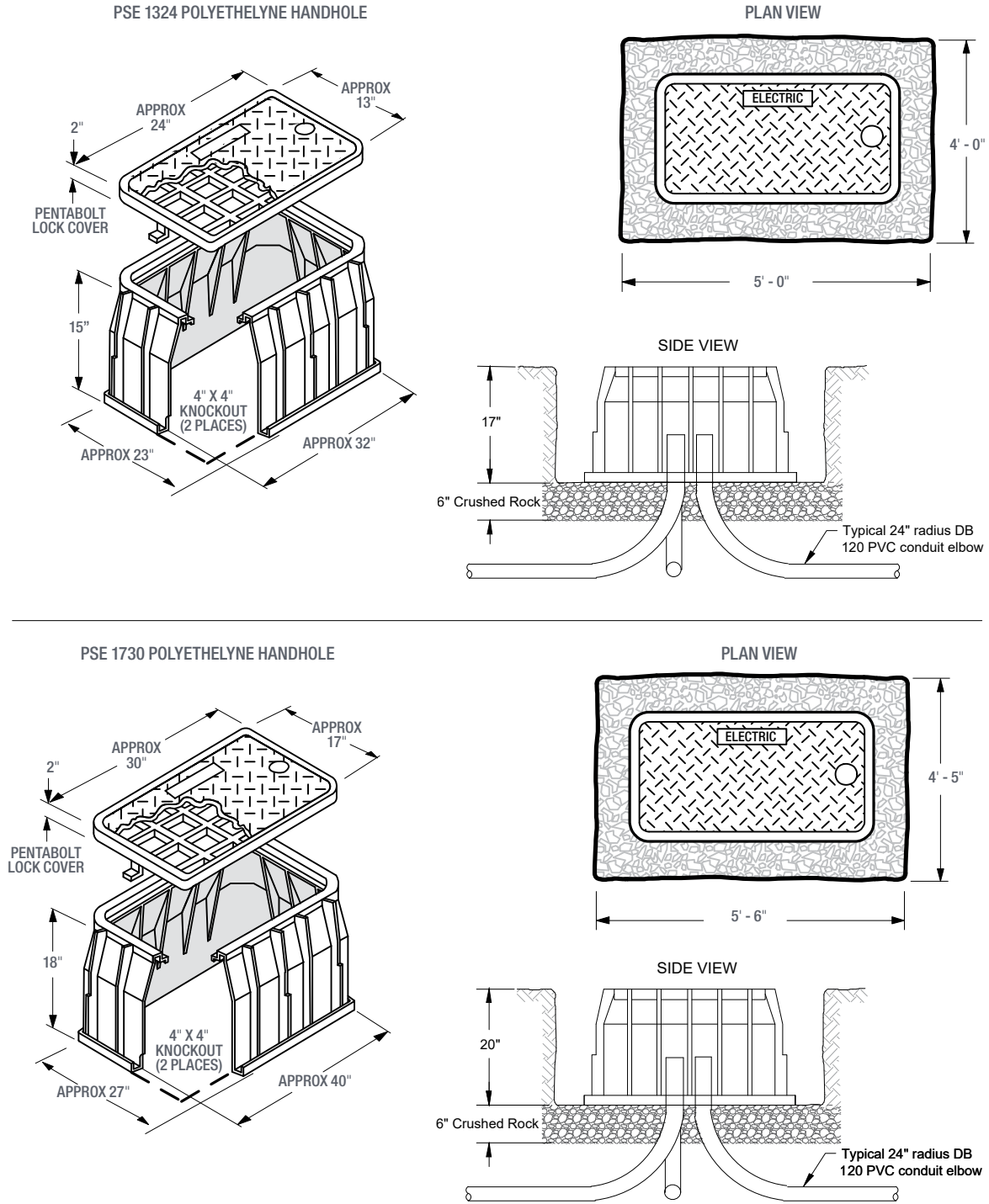
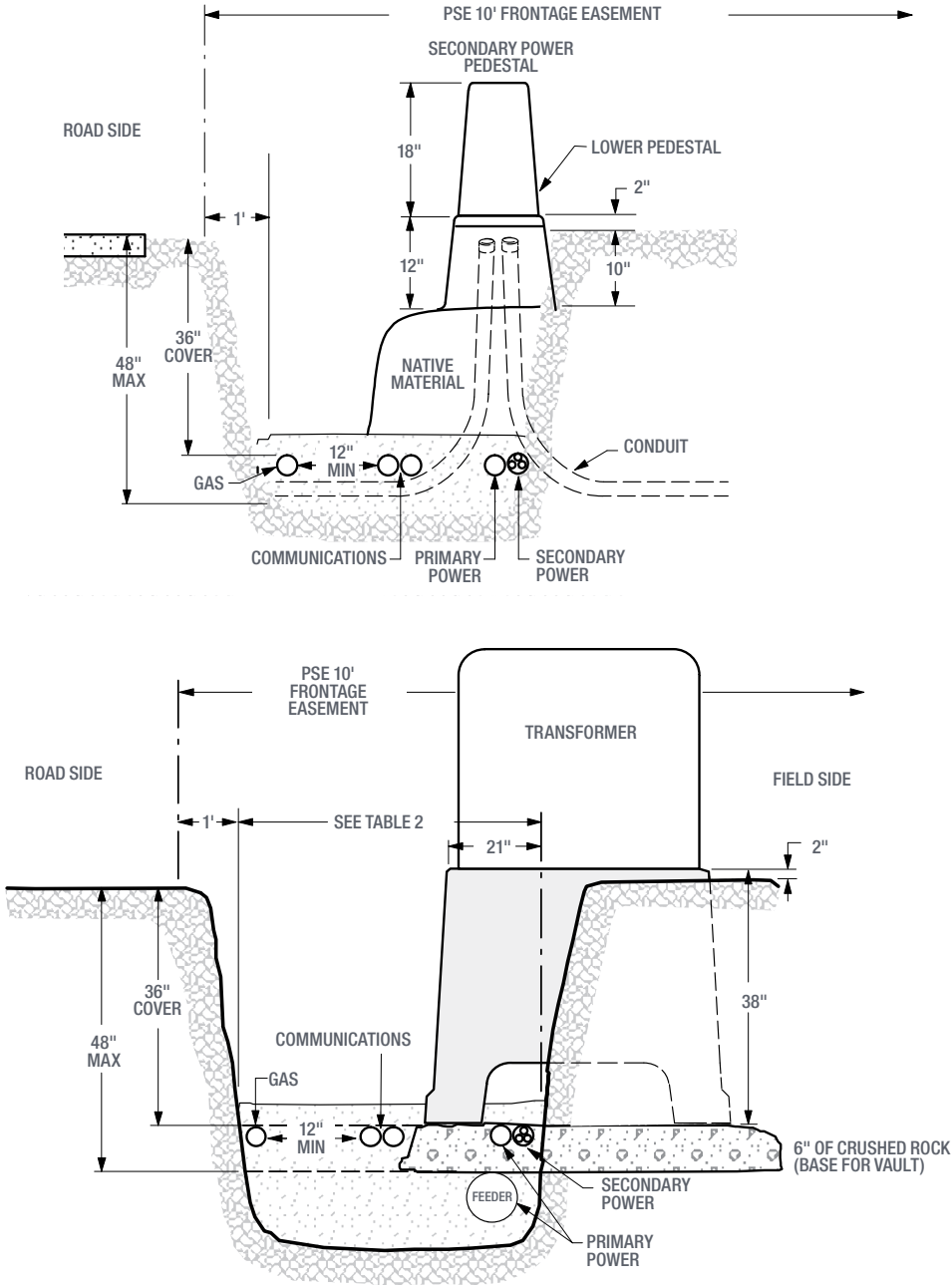

Figure 29 Joint trench detail for secondary pedestals and vaults



### Vault location and access

Underground equipment must be readily accessible by workers and equipment during construction and for future operation and maintenance. Workers should not have to climb over or remove obstacles to gain access. Heavy construction equipment must be able to get close enough to the excavation to place the vault in the hole. Consider the underground equipment's weight and the lifting angle and swinging radius of the boom truck when choosing the underground equipment's location. Remember that dump trucks may need access if select fill is used for fill or if excavated material will be hauled away.

A clear and level working space is necessary for the operation and maintenance of underground equipment. The location must allow room to operate a switch handle, completely open a hinged steel door, or use a hotstick to install and operate equipment. In no case shall clearances be less than those required by code from combustible and noncombustible walls, bodies of water, fire escapes, etc.

The working space should be free from obstructions such as trees, shrubbery, poles, buildings, retaining walls, structures, fences, fire hydrants, decorative screens, ditches, streams, roadways, etc. Consider possible future structures and equipment that could interfere with clearances and accessibility.

### Vault backfill material

Backfill around vaults should consist of good compactible material such as clean earth fill, crushed rock, or sand. No voids should remain between the vault walls and the sides of the excavation.

Backfill beneath the vault shall be crushed rock, six inches deep, to stabilize the vault.

If the vault is located in a concrete drive or sidewalk, a felt joint is to be installed around its perimeter.

**Figure 30** Electrical vault access road cross-section

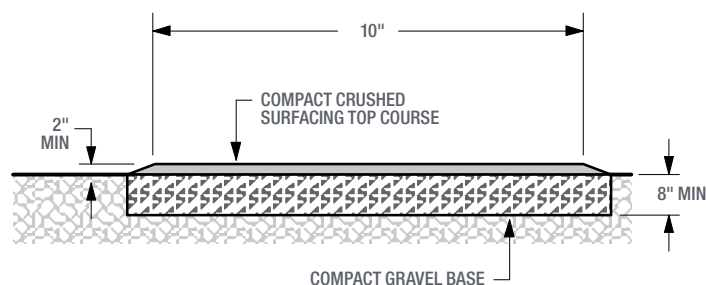

---

## Customer-supplied conduits

You may supply and install primary conduit for construction convenience.

If you supply the conduit for primary voltage cable, it will be owned and maintained by PSE and shall meet the following specifications:

- PVC electrical grade, Schedule 40 (or Schedule 80 if required in poor soil conditions).
- Gray in color.
- 2-, 3-, 4-, or 6-inch diameters as specified on the work sketch.
- Conduit bends shall be long radius bends, 36-inch minimum radius.
- Meet requirements in ASTM F 512 and NEMA TC 2.

---

## Terminating conduit at transformer

If the service line conduit is to extend into a minipad transformer, the customer shall install the service line conduit two inches into the mousehole on the face of the minipad that is closest to the residence and perpendicular to the face of the minipad. Refer to customer conduit entrance requirements (Figure 30).

If the service is connected to a submersible transformer in a vault, a qualified PSE representative shall be present when the knockouts are broken out and while the service line conduit is placed two inches into the vault.

---

## Excavating to expose existing buried primary voltage power lines

Routinely, PSE must uncover existing buried primary power cables in order to maintain, intercept and reroute, or cut new equipment into the circuit such as transformers or J-boxes. In these situations, the excavation taking place must be coordinated with the customer with respect to the hazards a buried energized line presents. Customers preparing trench up to a cable intercept point shall not uncover the cable ahead of the scheduled date for line work. Customers preparing a trench route to a cable intercept point must stop 3 feet from locate marks prior to the start of PSE line construction work. Only once the cable is isolated, tested, and grounded by qualified electrical workers, rendering the cable de-energized, may a customer proceed to expose PSE's cable through normal safe work and digging practices.

# Chapter 5

## Meter installation

---

This chapter provides you with PSE’s requirements for the metering equipment that you must provide to hook up your new service. Please follow these requirements to avoid a delay in your service hookup. If you have any questions about this information, call your Customer Construction Services (CCS) Representative.

Please see **Meter Socket Catalog Numbers (Form 7517)** for information on preapproved meter catalog numbers. It is located on PSE’s [Construction Services Guides and Handbooks web page](#).

---

## Service rating options

PSE’s metering equipment requirements for single-family residential structures (not apartments or condominiums) are based upon the following single-phase service ratings:

Voltage	Ampere rating
120/240	200 A
120/240	400 A
120/240	over 400 A *

\* If you need a three-phase service, please contact your CCS Representative. Refer to the PSE **Electric Service Handbook for Non-residential Projects, Permanent and Temporary Service (Form 1220)** for three-phase metering requirements.

---

## Responsibilities

### Puget Sound Energy

PSE is responsible for installing the meter, service line, and current transformers (CTs).

### Customer

You are responsible for providing and installing all service entrance equipment (including the meter base/socket and CT enclosure).

---

## Customer equipment

The customer load monitoring equipment shall be installed only on the load side of PSE metering. No customer equipment shall be allowed inside a meter or current transformer enclosure. This includes customer load monitoring and control devices.

**NOTE:** Meter base/socket and current transformer enclosures shall not be used as junction boxes

---

## Meter bases/sockets

### General requirements

The meter base/socket you purchase and install shall meet the following general requirements:

- Be a ring-type socket that includes a screw-type, stainless steel, or aluminum meter ring (snap-type rings must be stainless steel).
- Be Underwriters Laboratories (UL) approved.
- Be rated for exterior use and be rain-tight according to NEMA-3R.
- Have all unused openings tightly sealed from the inside of the socket.
- Be plumb and securely fastened to the supporting structure.
- Have a cover that is securely attached to the meter base/socket case.

**NOTE:** Meter base/socket and current transformer enclosures shall not be used as a junction box.

### Meter base/socket location

For single-family residences and manufactured and mobile homes, you are required to install your meter base/socket in a place that is accessible to PSE. All locations are subject to approval by a PSE Representative. If you have questions regarding meter locations, call your CCS Representative.

Meter bases/sockets and current transformer (CT) enclosures must be located:

- Outside.
- On the front one-third of your home closest to normal public access.
- In an area that is not subject to being fenced or walled in (such as patios, decks, porches, breezeways, backyards, and carports).
- On a structure that is owned by you.
- For Alternate Dwelling Units (ADUs), or duplexes, identify which property each meter belongs to.

These locations allow PSE to:

- Read your meter in a cost-effective manner.
- Maintain your meter efficiently.
- Disconnect your service in case of fire.

Meter location information is provided in the **Electric Underground Service Installation Requirements** ([Form 6080](#)).

### Labeling

When there are multiple meter sockets on the same property, or the meter socket is remotely located, labeling is required. PSE requires engraved **phenolic nameplates** or adhesive die-cut labels at least 1-inch high. Service will not be established until marking is complete.

**NOTE: Felt-tip pens and label maker tape are not considered permanent marking.**

### Grounding requirements

All meter bases/sockets, enclosures, and conduit shall be bonded and grounded in accordance with the NEC.

### Disconnecting means and its sequence

For those services where a disconnect switch is installed, the meter shall be ahead of the disconnect switch. The service/safety disconnect must be collocated within 5 feet of the meter. Each meter shall have a corresponding disconnect.

**Meter/panel  
combo units**

For overhead service, meter/panel combo units must meet the requirements in Chapter 3.

For underground service, these units must meet the requirements in Chapter 2, unless the line side conductors terminate below the meter base. If line side conductors terminate below the meter base and are bussed up to the top jaws, the minimum dimension for width and height is no longer required.

**NOTE:** If using this type of service equipment, please check with your local or municipal inspector to determine if it meets updated NEC 2020 codes for disconnects. PSE requires this type of equipment to be hot sequenced and does not allow a disconnect ahead of the meter socket.

**Residential  
meter bases  
with NEC  
required  
disconnect**

It is the customer's responsibility to ensure all external access points on the meter equipment are secured. PSE suggests/recommends that the customer lock external disconnect access for public safety/against possible tampering. This includes any areas where wires or panels can be accessed. PSE will lock/seal the meter ring and all compartments that contain PSE wire.

**Residential  
modified  
services  
installing new/  
upgrading  
existing with  
NEC required  
disconnect  
style meter  
(occupied  
structure)**

Customers making modifications to their service (including a new/upgraded meter base, and an upgrade/work on the panel) will have their service disconnected to accommodate the cutover. The service shall not be reenergized until all new customer wires are landed with grounding and bonding in place. Use of the disconnect alone is not sufficient for PSE to leave the service energized for safety concerns.

## Clearance requirements for meter installations

The following clearances are required around all meter installations. It is your responsibility to provide and maintain these clearances.

- The top of the meter shall be between 4 and 6 feet above finished grade (except meter pedestals).
- For any meter base in a flood zone, a raised platform may be required in order to allow PSE access and to meet the height requirement in Figure 31.
- A working space of 36 inches wide by 36 inches deep (see Figure 31) is required around the meter. This working space is to be kept clear of any obstructions including landscaping. Six feet of worker headroom is required.
- There shall be a minimum horizontal and vertical clearance of 18 inches between the center of the electric meter and any obstruction (see Figure 31).
- If a recessed meter base/socket is installed, a 10-inch clearance is required from the meter to the closest portion of the wall (see Figure 32).
- If a flush or recessed meter base/socket is installed, the siding or finished surface of the structure shall not overlap the cover of the meter base/socket.
- If a flush or recessed meter base/socket is installed, space must be left around the locking tab for PSE to install a meter seal.
- Meter base/socket may be recessed a maximum of 4 inches behind a finished exterior surface.

**Figure 31** Meter base/socket minimum clearances

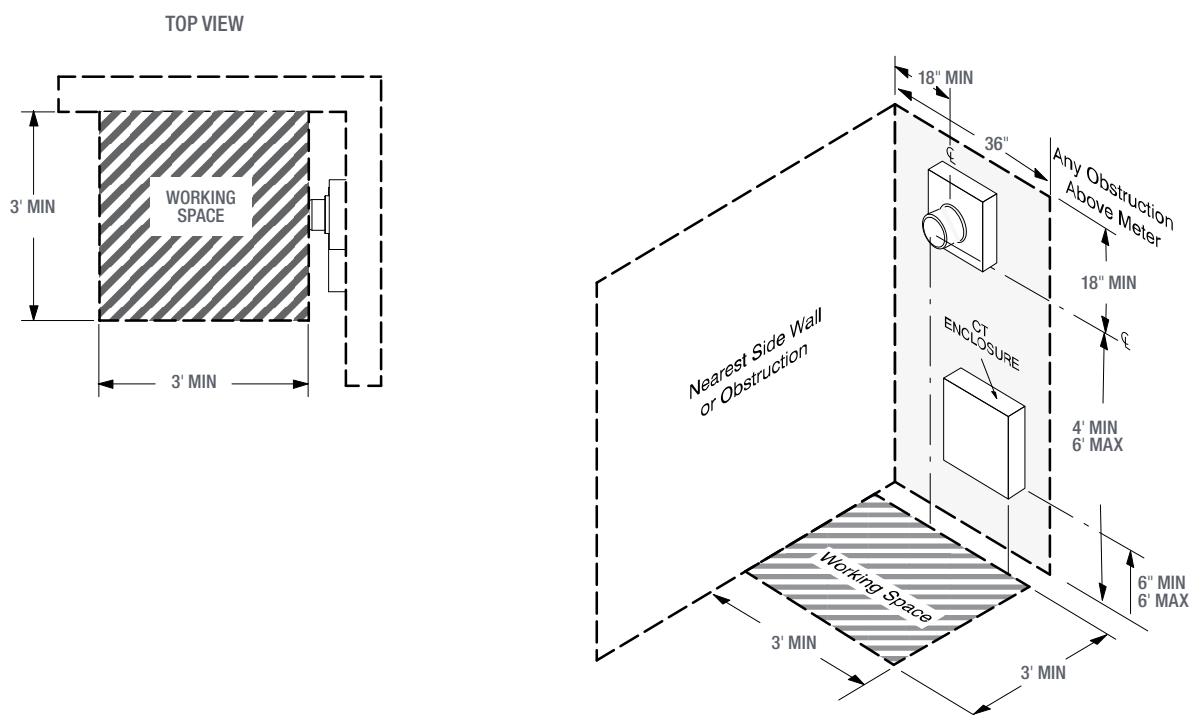
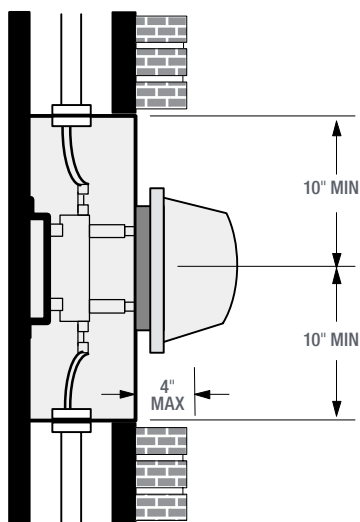

Figure 32 Recessed meter installation clearances



## 200 A services

### Single-family residential

The 120/240 V, 200 A service is the most common service installed by PSE. Typically, it is installed on homes with a living area of less than 2,500 square feet. However, depending upon what type of equipment you are installing, you may want a larger service. It is your responsibility to determine your electrical requirements and to notify PSE of the size of service you would like. Refer to Chapter 1, Table 3, for service size information.

### Underground

In addition to the meter base/socket requirements earlier in this chapter, meter bases/sockets for 200 A underground services shall:

- Be rated for 120/240 V and 200 A.
- Contain four meter jaws and one connection point for the neutral conductor.
- Be at least 4-1/4 inches deep, 11 inches wide, and 14 inches high.
- Accept 2-1/2 inch PVC conduit.
- Have lugs (electrical connectors) that are marked to accept 4/0 aluminum conductors.

**NOTE:** Use only the conduit knockouts on either side of the bottom of the meter base/socket enclosure for PSE's service cable.

**Overhead**

In addition to the meter base/socket requirements earlier in this chapter, meter bases/sockets for 200 A overhead services shall:

- Be rated for 120/240 V and 200 A.
- Contain four meter jaws and one connection point for the neutral conductor.

**Outbuildings (overhead or underground service)**

Meter bases/sockets for 200 A (or less) services to single-family residential use outbuildings (such as garages, shops, single-family wells, or noncommercial barns) must meet all the requirements listed in this chapter for either underground or overhead services.

**NOTE:** If an outbuilding is used for a commercial operations, please refer to the PSE **Electric Service Handbook for Non-residential Projects, Permanent and Temporary Service (Form 1220)**, as you will have additional requirements including customer-provided service conductor and a manual bypass meter base/socket.

**Figure 33** Residential meter socket wiring diagrams

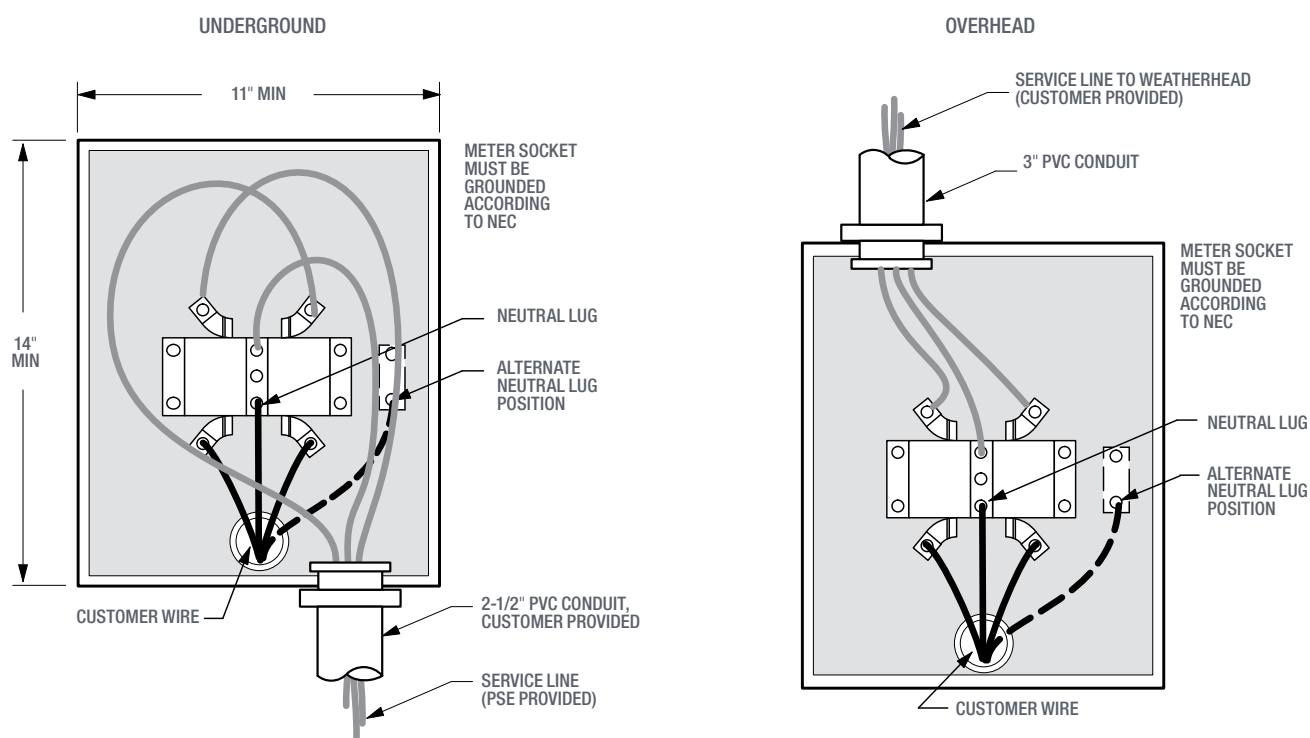

## 400 A self-contained services

The meter base/socket required for a 120/240 V, 400 A service is called a Class 320 meter base/socket (see Figures 34 and 35). It is larger than the 200 A meter base/socket, but it is still a self-contained meter base/socket. It can be installed on residences where the continuous current rating is 320 A or less.

**NOTE:** If your structure requires more than 320 A of continuous current, you are required to install a CT service (refer to the 400 A current transformer (CT) services section in this chapter).

### Underground

In addition to the meter base/socket requirements listed earlier in this chapter, Class 320 meter bases/sockets for 400 A underground services shall:

- Be rated for 120/240 V and 320 A continuous current.
- Contain four meter jaws and one connection point for the neutral conductor.
- Contain a Class 320 manual block bypass (see Figure 34).
- Have lugs that will accept 350 MCM aluminum wire.
- Accept 3-inch steel or Schedule 40 or 80 conduit through a knockout in the bottom left corner or center of the enclosure.
- Have at least an 8-1/2-inch clearance between the bottom of the lugs and the bottom of the enclosure (see Figure 34).

Figure 34

Typical arrangement of service conductors for underground class 320 meter base/socket

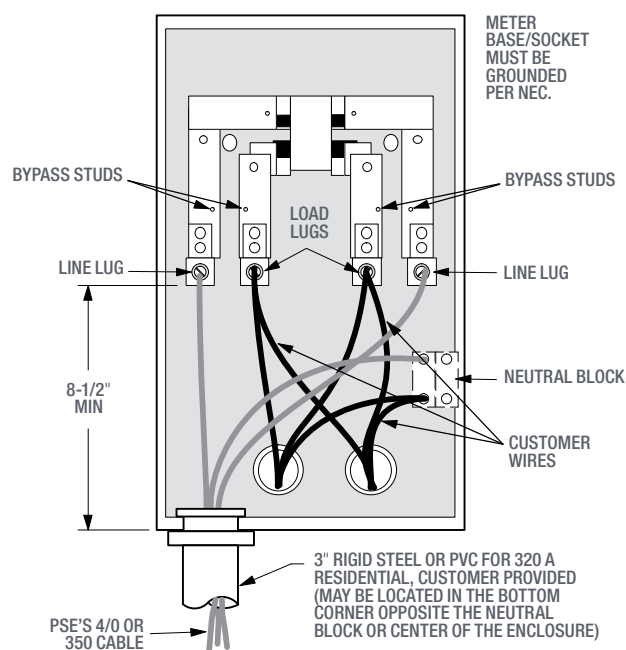

**Overhead**

In addition to the meter base/socket requirements listed earlier in this chapter, Class 320 meter bases/sockets for 400 A overhead services shall:

- Be rated for 120/240 V and 320 A continuous current.
- Contain four meter jaws and one connection point for the neutral conductor (see Figure 35).
- Contain a Class 320 manual block bypass.

**Figure 35**

Typical arrangement of service conductors for overhead class 320 meter base/socket

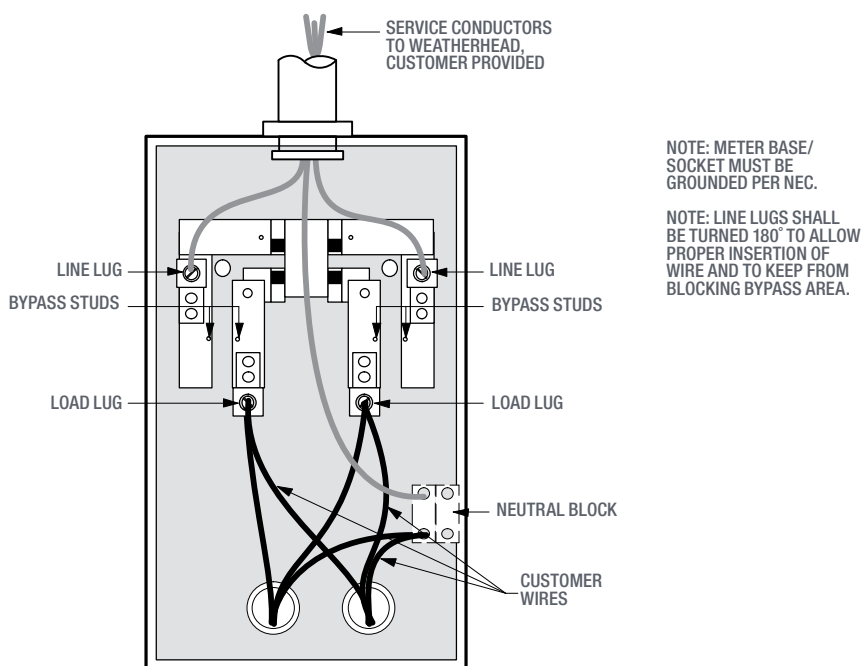
**Outbuildings  
(overhead or  
underground  
service)**

The metering requirements for 400 A services to outbuildings are the same as the metering requirements for 400 A services to single-family residential structures.

## 400 A current transformer (CT) services

120/240 V, 400 A CT services are available at an additional charge. This service requires a different meter base (see Figure 36). It also requires additional equipment (CT enclosure, conduit, CT mounting bracket, etc.). The CT enclosure must be located on the outside of the structure that it serves. Contact your CCS Representative for more information.

**NOTE:** The CT enclosure cannot be used as a junction box or bus gutter.

**Figure 36** Instrument-rated (CT) meter bases/sockets

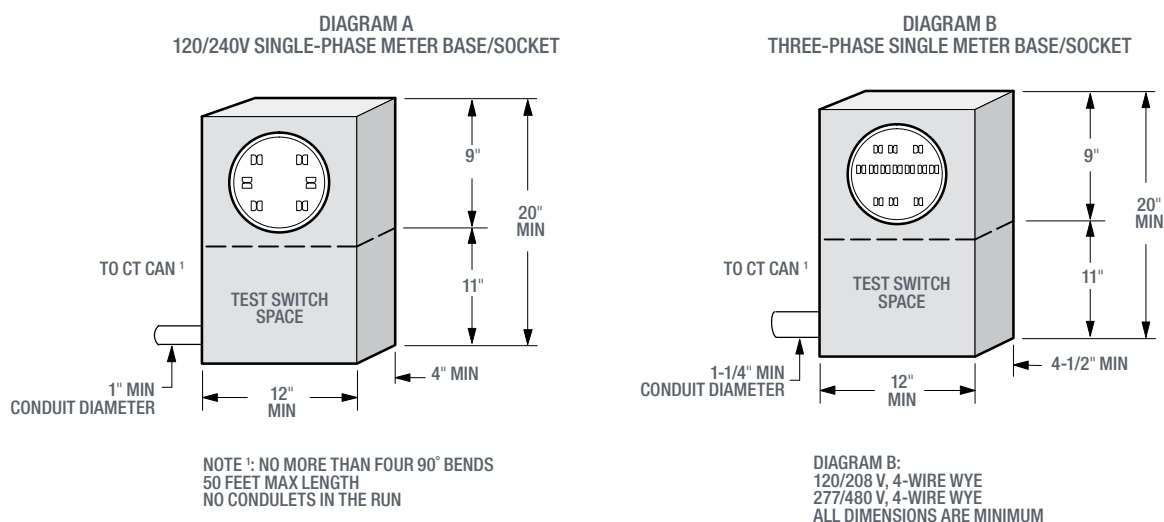

## Services over 400 A

All 120/240 V services over 400 A (320 A continuous current) require CT metering. Figure 37 shows a CT mounting base. Please contact your CCS Representative for more information. Table 7 describes minimum CT enclosure dimensions.

**Table 7** Current transformer (CT) enclosure dimensions (minimum)

Phase	Switch Ampacity	No. of Transformers	Width	Height	Depth
1 *	400-800	2	24"	48"	11"
3 *	201-800	3	36"	48"	11"
3 **	over 800	3	**		

\* When enclosure dimension is greater than 24" x 48", a single side-hinged door is required.

\*\* Services over 800 A require a switchboard designed to EUSERC specifications. Services from 201-800 A may be switchboard designed to EUSERC specifications.

Figure 37 Single-phase CT mounting base

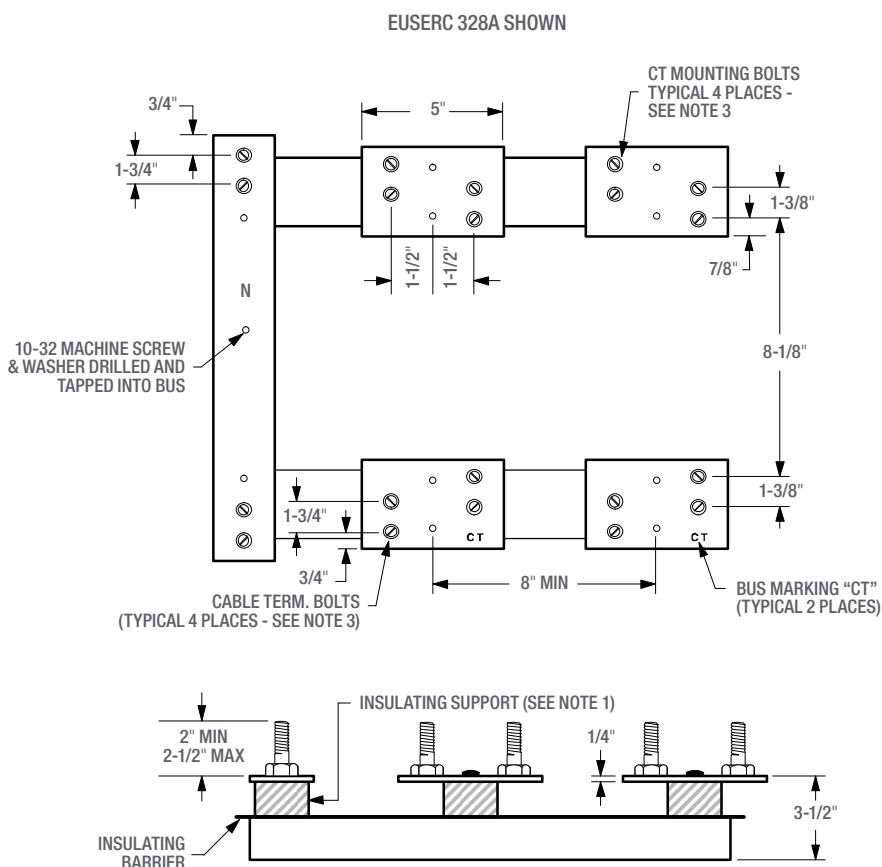
**Notes:**

1. Insulated supports shall be rated for the serving voltage and have sufficient mechanical strength for the application.
2. Mounting base accepts bar-type current transformers only.
3. Two 1/2-inch steel bolts shall be provided for each cable terminating position and each bolt shall be furnished with a spring washer and a nut. The spring washer may be either a cone-type (belleville) or a split-ring washer and a flat washer. Bolts shall be secured in place and spaced as shown. All parts shall be plated to prevent corrosion.

# Chapter 6

## Customer generation

---

This chapter provides PSE’s requirements to interconnect and operate customer-owned and installed generation sources in parallel with PSE’s electric distribution system. Customer generation sources include fuel cell, hydroelectric, biomass, solar, battery, or wind power generators.

---

### Responsibilities

#### Puget Sound Energy

PSE will review all interconnection applications, and once approved, will issue the Approval to Construct. Once the customer has completed the installation, passed the NEC inspection, and provided the Notice of Completion to PSE, PSE will commission the system, install meters as applicable, and issue the Approval to Energize (also known as Permission to Operate).

#### Customer

The customer shall submit an application to interconnect ahead of constructing/ installing a customer-generation system. This includes any system that will interconnect with and operate in parallel with PSE’s electric distribution system, regardless of the intent to export energy onto PSE’s system. Customers shall also submit an application to modify an interconnected system prior to making material changes to an existing system. Failure to obtain approval ahead of construction may result in delays and unanticipated costs for any corrections necessary. All customer electrical equipment must comply with the NEC and any state or local code requirements.

After installation is complete and has passed the NEC inspection, the customer shall submit the Notice of Completion to PSE. The customer will then be given Approval to Energize (also known as Permission to Operate) the system, in most cases, once PSE personnel visit and inspect the generation equipment.

---

## General requirements

Customer generation systems may be connected to and operate in parallel to PSE's facilities in accordance with Electric Tariff G, Schedule 152. The provisions of Schedule 152 apply to all Interconnections, including without limitation Net Metering Interconnections (renewable generating systems up to 100 kW ac), eligible for special considerations outlined in Schedule 150.

Additional information about PSE products, services, and rates available for customer generating systems can be found at:

- [pse.com/netmetering](https://pse.com/netmetering) (for solar, solar plus batteries, and other renewables up to 100 kW ac)
- [pse.com/distributedrenewables](https://pse.com/distributedrenewables) (systems outside of Net Metering)

The design of these systems shall meet PSE's standards for voltage flicker and harmonics and will be served by PSE at a standard service voltage (see Chapter 1, Table 2).

---

## How to apply for interconnection

Customers must submit a signed Interconnection Application (including system diagram) using PowerClerk, our online application portal.

To apply for interconnection of a net metered system (including solar and solar plus battery systems up to 100 kW ac), visit <https://psenetmetering.powerclerk.com>.

To apply for interconnection of batteries that are not paired with solar (or other systems that do not qualify as net metered), please visit <https://psedistributedgenerationinterconnections.powerclerk.com>.

---

## Interconnection system diagrams

For PSE to review the interconnection application, a one-line diagram and site plan must be included. The one-line diagram shall note equipment model numbers, power output capacity, and site address. The diagram shall schematically represent all relevant equipment from the generator through to PSE's electric distribution system, and the site plan shall provide a birds-eye view of the relative locations of this equipment including:

- Generator(s) such as solar modules
- Inverter(s)
- Battery bank (as applicable)
- All disconnect switches, including any PSE-required disconnect switch labeled as a visible/lockable break (as applicable)
- Combiner panels (as applicable)
- Sub panels, including critical loads panels (as applicable)
- Gateways, transfer switches (as applicable)
- Main electrical panel
- Specific point of interconnection (designated breaker or location of line side tap)
- Conductor schedule
- Equipment schedule
- Production meter (as applicable)
- Service meter (net meter)
- Switch gear specifications (as applicable)

For modifications to existing interconnected systems, the diagram must include the existing and newly proposed elements of the system, as they will operate together.

PSE prefers the one-line diagram to be on a single page when possible.

A system diagram guide can be found at [pse.com/netmetering](https://pse.com/netmetering).

---

## Meter location

Net meters and production meters are subject to the meter location requirements defined in Chapter 5 of this handbook.

Production meters are optional. When a production meter is requested, it must be shown on the system diagram and noted on the Interconnection Application. A **single** production meter must be able to accurately measure all and only energy produced by the generating system and must be located adjacent to the net meter.

“Adjacent” is defined as between 10 inches to 6 feet center-to-center along the same wall. Installers shall not round corners.

Production metering for an expansion of a Generating Facility (defined as all generation behind a single net meter) will be reviewed on a case-by-case basis. The priority is for “all or none” of a generating facility’s energy output to be measured.

More information about why a customer may want production meters can be found at [pse.com/netmetering](https://pse.com/netmetering).

---

## Meter socket requirements

When an optional production meter is requested, the customer shall provide and install the meter socket. Customer-provided metering equipment shall meet the requirements stated in Chapter 5 of this handbook. Production meter sockets shall not be “jumped” prior to PSE’s installation of the meter.

Customers may not tap at or in a meter base/enclosure.

---

## Labeling and signage requirements

The labeling requirements in Chapter 5 of this handbook apply to net and production metering enclosures. In addition to those requirements, meter enclosures shall be labeled with permanently affixed signage at the production meter and net meter enclosures to identify their function (i.e., "NET METER" or "PRODUCTION METER"). Where a customer generation source includes a battery that operates in parallel with the grid, whether in combination with other generation sources or as a stand-alone battery, an additional permanently affixed label that reads "BATTERY" in red color must be affixed to the meter base. Where metering is accomplished at different voltages, the signage must also identify the voltages at which the meters are energized.

**Multiple Disconnect Locations:** Where a generating system utilizes more than one disconnect point to meet PSE’s disconnect switch requirement (detailed below), phenolic labels must specify which numbered disconnect is being referenced (e.g., "DISCONNECT 1 OF 2" and "DISCONNECT 2 OF 2"). In addition to labeling each disconnect that is a part of meeting PSE’s disconnect switch requirement, if disconnects are not colocated with the meter, the customer must provide a directory at the service meter indicating where the disconnect(s) are located and vice versa.

Labels shall conform to the requirements of NEC Article 690. All labeling should be capitalized. PSE requires engraved phenolic nameplates or adhesive die-cut labels at least 1 inch high, with raised or cut-out lettering that is a minimum of 3/4 inch high.

---

## Disconnect switch requirements

PSE must have the ability to disconnect customer generation from PSE's system for employee protection. In many cases, PSE will pull and lock out the service meter to isolate the customer with an interconnected generating system from the grid during a PSE system outage. However, this is not safe or possible in all situations, and a visible lockable air gap may be required.

A visible air gap, lockable disconnect switch is required in any of the following scenarios:

- Maximum generation capacity of combined generation sources, including batteries, is greater than 25 kW ac.
- Electric service is three-phase.
- Electric service is CT-metered.

When a visible air gap, lockable disconnect switch is required, it must be a single switch that isolates the entire generating system and be colocated with the electric service (net) meter.

An exception is allowed in the following circumstances:

- When a single required visible, lockable disconnect switch is accessible, but is not colocated with the electric service (net) meter, labeling must provide a directory at the service meter indicating where the disconnect is located and vice versa.
- When 2 or more generating sources (separate PV arrays, PV and batteries, etc.) are interconnected at different points (different breakers, subpanels, etc.), multiple disconnect switches may be used with proper labeling (see labeling requirements in previous section).
- When a PSE disconnect switch is required for PV plus batteries because generation capacity is greater than 25 kW ac on single phase service, no greater than 400 amps and has a self-contained 2S meter, Disconnect 1 of 2 may isolate a portion of the generating capacity that when in the off position, brings the total capacity down to below 25 kW ac and Disconnect 2 of 2 is the service meter pull. Labeling to clarify this sequencing is required.

When the generation system includes optional production metering, the disconnect switch shall be connected to the load side of the production meter (between the production meter and electrical panel) in case of 480 V self-contained production meters.

---

## Commissioning

Commissioning by PSE is to ensure that the customer generating system was installed according to PSE standards and the approved plans. In most cases, PSE will conduct an on-site inspection, including testing and the installation of meters as applicable.

Unless otherwise noted, the customer must leave the customer generation system off until PSE commissions the system, conducts testing as applicable, and issues the Approval to Energize (also known as Permission to Operate).

- **Net Metered Solar System without Batteries, with an accessible ac disconnect switch:**  
The system must be left off at the accessible ac disconnect switch after the NEC inspection until PSE commissioning and the Approval to Energize. The system is expected to turn on for testing when PSE puts the disconnect switch in the on position.
- Net Metered Systems that include optional production metering shall be left on at the disconnect switch with the PSE production meter socket covered and empty. The system is expected to turn on for testing when PSE installs the production meter.
- **Net Metered Solar System without batteries, without an accessible ac disconnect switch, or one that cannot be left in the off position (whole home disconnect switch):**  
The system must be left off at the breaker after the NEC inspection and the customer/installer should indicate on their Notice of Completion that an appointment is needed for PSE commissioning.
- Modification to an existing interconnected solar system that requires an added disconnect switch should follow the same guidelines as for other Net Metered Solar Systems above.

### Noted Exceptions

- Residential battery-only systems shall be left on after the NEC inspection and submittal of the Notice of Completion to PSE.
- Net Metered Systems with solar and batteries should be left on and in full export mode after the NEC inspection, once PSE has received the Notice of Completion, completed the desktop review, and notified the customer that a commissioning site visit is the next step. This ensures that the batteries will be charged, enabling PSE to conduct interconnection testing upon arrival.
- Modifications to existing interconnected solar systems without batteries that do not require a new utility disconnect may be left on after the NEC inspection and the Notice of Completion has been submitted to PSE.

PSE maintains the right to conduct an inspection to verify compliance with its guidance at a later date if problems arise or indications of possible noncompliance to NEC Article 720 or the applicable PSE guidance documentation are present.

---

## Testing

During system commissioning, or at any point to address interconnection safety concerns, PSE may test the customer generating system.

During a loss of grid ac input or a such simulated testing:

- The available dc voltage present at the solar interconnection point or utility point of connection (POC) shall be no more than 30 Vdc or 15 Vac within 30 seconds of rapid shutdown initiation. If a dc voltage is constant and measurable, it shall measure below 30 Vdc or 15 Vac between any two conductors or any conductor and ground.

Refer to NEC Article 690.12, Rapid Shutdown of PV Systems on Buildings, and UL 1741, Standard for Inverters, Converters, Controllers and Interconnection System Equipment for Use with Distributed Energy Resources, for more details.

- The available dc current present shall be limited to 0.5% of the reference of interconnection per IEEE 1547, Section 7.1, Limitation of DC Injection of 0.5% of Reference Point of Interconnection.

(That translates to 200 amps x 0.5% = 1 amp dc limit for a CL200 net meter point of reference.)

---

## Resources

Additional information about interconnection and net metering with PSE (including Rate Schedules 150 and 152, and system diagram guides) can be found at [pse.com/netmetering](https://pse.com/netmetering).

When a standards variance is requested, it must be submitted for PSE review and approval prior to system construction. Submit variance requests to [netmetering@pse.com](mailto:netmetering@pse.com) for net metering projects or [distributedrenewables@pse.com](mailto:distributedrenewables@pse.com) for all other customer generation projects.

Technical interconnection and interoperability requirements for distributed energy resources >100 kW or not qualified as Net Metered systems can be found [here](#).

# Chapter 7

## Temporary services

---

### What this chapter contains

In this chapter you will find answers to questions such as:

- What are the installation requirements for underground and overhead service?
- What are the trenching requirements?
- How do I locate existing underground utilities before I dig?
- How do I get my temporary service energized?

---

### Definition

A temporary (temp) service is a means of supplying electricity to your site for less than one year. Typically, a temporary service provides power for the construction phase of your project, while provisions are being made for your permanent power system.

Temp service is provided underground or overhead depending on available PSE facilities.

---

### Obtaining your temporary service from existing power facilities

The following information applies to your temporary service installation:

- Determine if you need overhead or underground service (see Preface, Figure 1 and Figure 2).
- Obtain an electrical work permit.
- Order underground utility locate service by contacting the 811 “Call Before You Dig” hotline a minimum of two business days before digging.
- Prepare the job site and install your temp service equipment (service post, pedestal, and meter base per illustrations found in this chapter).
- Obtain an electrical inspection approval of your temp service equipment (this is done by you or your contractor).
- Call PSE to request that your temp service be connected and energized after your electrical inspection is complete.
- Apply for permanent service.
- At your request, we will check your site to determine if engineering is required.

If you have any questions, please call Customer Construction Services (CCS) at **1-888-321-7779**. For information on permanent services, please contact CCS.

---

## Scheduling

Most temp services are connected to existing power facilities and engineering is not required. In these cases temp services are typically energized 3 to 5 days after your installation has passed inspection. Depending on complexity and work volume, time frames will vary.

---

## Customer charge for service

Charges vary due to the type of system we have in your area. Your CCS Representative will explain current temp service fees.

---

## Temporary meter base/socket requirements

You are required to provide a meter socket with the following specifications:

- A ring-type socket that includes a screw-type, stainless steel, or aluminum meter ring (snap-type rings must be stainless steel).
- Rated 120/240 V
- Single-phase
- Minimum rating of 100 A
- Maximum rating of 200 A
- Four jaws
- Underwriters Laboratory (UL) approved

---

## Temporary underground services

Temporary underground service is available in PSE's service area where the existing power facilities are installed underground.

The process and cost of obtaining your temporary underground service can vary, depending on the location of our existing facilities. If there is a power stubout, handhole, pedestal, or transformer located on your property adjacent to our existing facilities (see Preface, Figure 1), engineering may not be required. Simply install your temporary service facilities (see Figure 38 and Figure 39), obtain an electrical inspection, and call PSE to connect your temporary service.

### Meter location

To properly locate your temporary meter pedestal, set the meter pedestal on your property no more than 5 feet from the transformer, stubout, handhole, or pedestal.

Sometimes a distance greater than 5 feet is required such as when your home site is some distance from our existing facilities and you want your pedestal close to where your permanent service will be located. In this case, please contact a CCS Representative at **1-888-321-7779** for information on setting up a remote temporary underground service.

## Trenching and excavation requirements

It is the customer's responsibility to provide the trenching needed to connect to a power stubout (shown in Figure 38). The cable you provide is to be sized according to the NEC and have a minimum 24 inches of backfill coverage.

**NOTE:** A 4-foot-square excavation is required at the stubout to provide working room for our personnel to splice your cable to ours.

If the connection point to PSE facilities is a handhole, pedestal, or transformer; trench up to the nearest side and leave your wires exposed. If you discover any other conductors while digging your trench, please leave them covered.

Remember to order underground utility locate service by contacting the 811 "Call Before You Dig" hotline a minimum of two business days before digging.

**NOTE:** Any trenching within 24 inches of existing underground facilities must be done by hand.

**Figure 38** Trenching requirements for power stubout

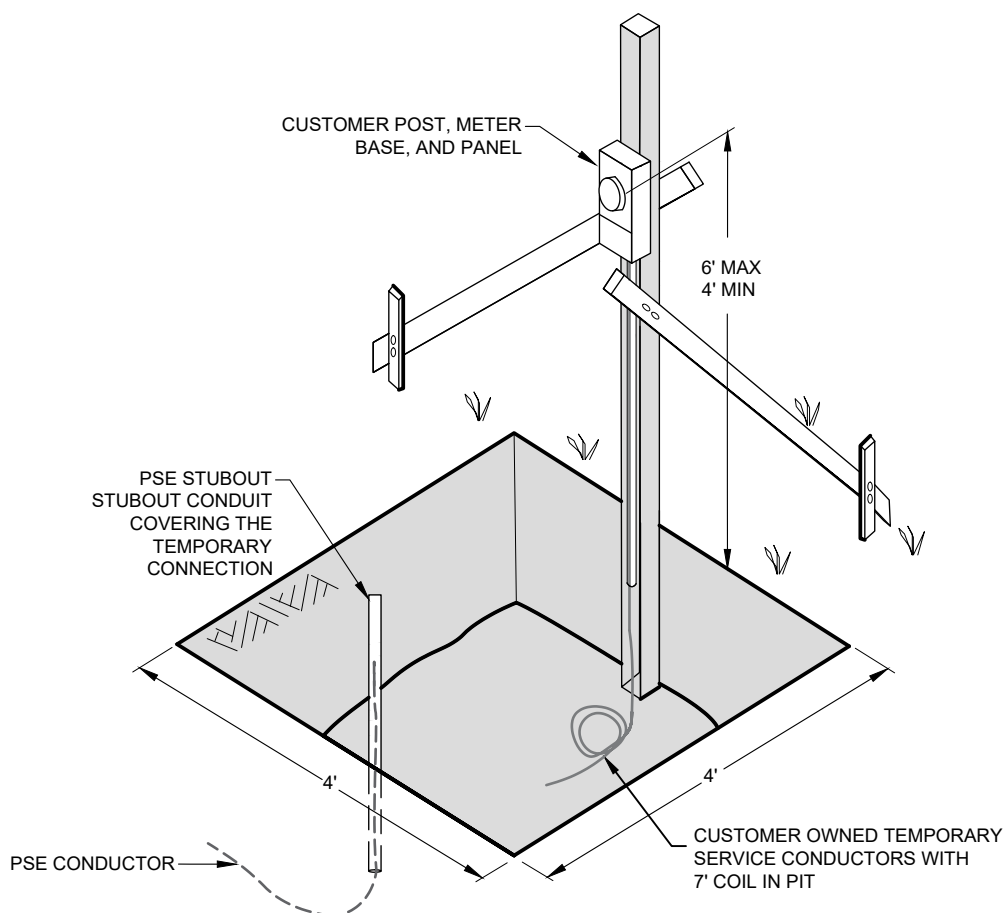

**NOTE:** 4' x 4' work pit is required to allow working room for the tools necessary to connect temporary service.

**Underground temporary service installation process**

The following items must be completed before PSE energizes your underground temporary service:

1. Contact a CCS Representative at **1-888-321-7779** and request your temporary underground service.
2. Obtain an electrical work permit from the inspecting agency.
3. Order underground utility locate service by contacting the 811 “Call Before You Dig” hotline two business days before digging.
4. Install your meter pedestal and meter base/socket in the appropriate location (see Figures 38 and 39).
5. Provide the appropriately sized conductor from your meter socket to PSE’s connection point. Please leave 5 feet of extra cable at the stubout or handhole, and 10 extra feet at a transformer. Consult the NEC for the appropriate cable sizes.
6. Obtain and pass an electrical inspection.
7. Trench up to and expose the PSE connection point at the stubout, handhole, or transformer.
8. If trenching is provided, cover your cable except in the work pit where our personnel will be splicing your cable to ours.
9. After the above items are complete, call CCS at **1-888-321-7779** and inform a CCS Representative that your installation has been inspected and that you are ready for your temporary service.

Figure 39 shows the standard temporary underground service installation that we recommend. The dimensions shown are the minimum acceptable.

Please do not deviate from our installation standards without approval from your CCS Representative. Doing so may extend the time frame for your service hookup.

If service needs to be connected in right-of-way, a permit will be required. This can take several weeks.

Figure 39 Temporary underground service installation

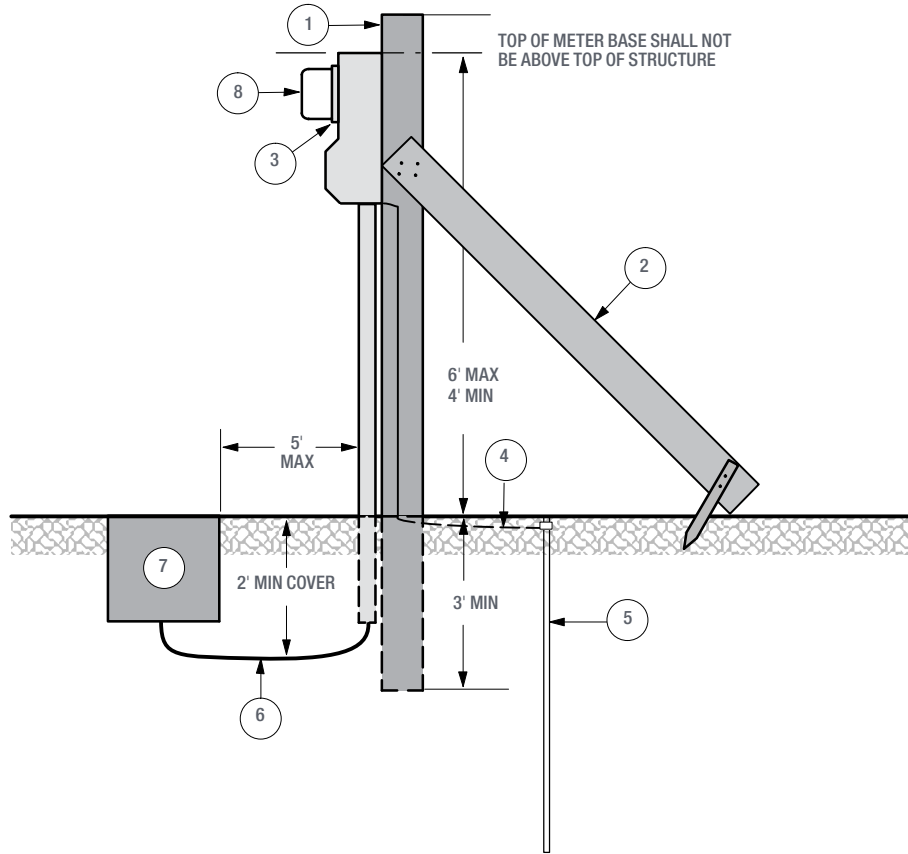

Items owned and installed by customer	
1	4" x 4" x 10' continuous single structure
2	2" x 4" bracing (post should be braced from two directions)
3	Meter socket and distribution panel (up to 200 A, 120/240 V)
4	Ground wire, in accordance with NEC/WAC
5	Ground rod(s), in accordance with NEC/WAC
6	Service entrance conductors in accordance with NEC

Items owned and installed by PSE	
7	Transformer, handhole, pedestal, or stubout
8	Meter

---

## Temporary overhead services

Temporary overhead service is available anywhere in PSE's service area where the existing electrical system is installed overhead.

The process and cost of obtaining your temp overhead service can vary depending on the location of our existing facilities. The least complicated and cheapest way a temp service can be installed is if a transformer is located on a pole alongside your property (see Preface, Figure 2). If this is the case, engineering may not be required. All you have to do is install your temp service equipment, have it inspected, and call Customer Construction Services (CCS) at **1-888-321-7779** to order your service. Once the above items are completed, your service will be connected within a few business days.

### Meter location

Your temporary meter post should be located on your property and within 70 feet of the PSE pole that will serve you. This limitation ensures that your temporary service pole can withstand the weight of the conductor. If a distance greater than 70 feet is required, or if PSE's pole is on the opposite side of the street, please call CCS for our review and approval prior to construction. A taller, stouter temporary service post with additional bracing could be required.

### Service line path requirements

In addition to the meter post distance limitation mentioned above, the service line path requirements are:

- The path that the service line will take should not cross property belonging to other individuals.
- If the service line will pass through trees or brush, clear a path to allow our service personnel to run the line and to allow the lines to hang without contacting trees or limbs. Maintaining this clear path is the customer's responsibility.
- The service line path should avoid areas where vehicular traffic will occur, unless your temporary service post height is increased to provide adequate clearance (see Figure 40).

### Clearance requirements

The National Electric Code (NEC) and the National Electric Safety Code (NESC) have established minimum clearance requirements to maintain safe heights for electrical conductors over various terrains.

Figure 40 shows the clearance requirements for the types of terrain most commonly encountered.

The NEC and NESC require the lowest point of a service conductor to be at least 12 feet aboveground. The bottom of the drip loop must be a minimum of 10 feet above the ground.

You are required to provide a point of attachment on your service pole that will allow PSE to install the conductor and maintain the required clearances.

If you need further details, please consult the current issue of the NEC, or contact the state or local electrical inspector for your area.

Figure 40

Minimum clearance requirements upon installation

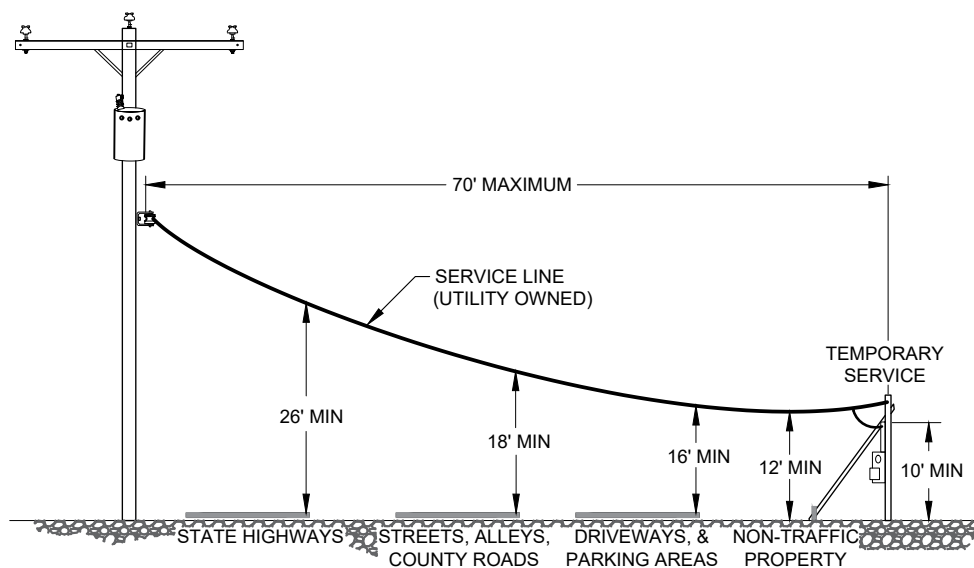

### Overhead temporary service installation process

The following items must be completed before we can energize your service:

1. Contact a CCS Representative and request your temporary overhead service.
2. Obtain an electrical work permit from the inspecting agency.
3. Install a meter pole and meter socket. Temporary service equipment on trees is not acceptable.
4. Obtain and pass an electrical inspection.
5. After these items are completed, call CCS and inform a CCS Representative at **1-888-321-7779** that your installation has been inspected and that you are ready for temporary service.

Figure 41 shows a typical temporary overhead service installation.

Consult with your CCS representative for non-typical installations.

**Figure 41** Temporary overhead service installation

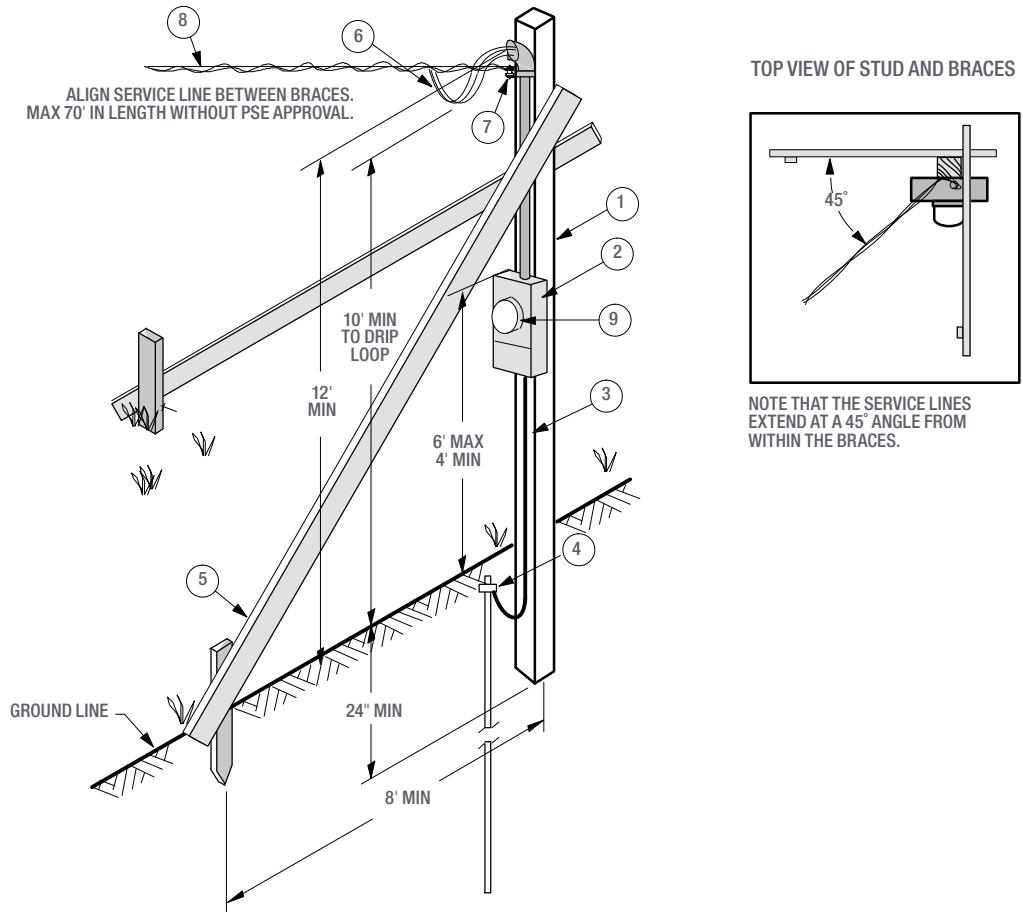

Items owned and installed by customer	
1	4" x 4" x 16' or 2" x 10" x 16' minimum, continuous single structure. No timber
2	Meter socket and distribution panel (up to 200 A, 120/240 V)
3	Ground wire, in accordance with NEC/WAC
4	Ground rod(s), in accordance with NEC/WAC
5	2" x 4" brace (two required)
6	Service entrance conductors - 18" out of weatherhead minimum
7	Insulated clevis (point of attachment)

Items owned and installed by PSE	
8	Service line
9	Meter

## Chapter 8

### Disconnection and modification of service

---

There may be a time when your electric service needs to be modified. You may wish to have your service disconnected, reconnected, moved from its current location, relocated, or simply de-energized. This may involve lengthening, shortening, transferring, or rerouting the existing service.

---

#### Disconnection of your meter

If you need the power disconnected to work on your side of the meter, without actually removing the wire from the insulator, PSE will perform a simple disconnect/reconnect service for you.

PSE defines a “disconnection” as the disconnection or reconnection of single-phase, self-contained meters or service lines at the meter base or weatherhead for the convenience of the customer.

If the wire has to be removed, relocated, or otherwise manipulated as this becomes a modified service, refer to the Modified services section below. Check with your CCS Representative to verify any charges that you may incur.

---

#### Residential modified services installing new/upgrading existing with NEC required disconnect style meter (occupied structure)

Customers making modifications to their service (including a new/upgraded meter base, and an upgrade/work on the panel) will have their service disconnected to accommodate the cutover. The service shall not be reenergized until all new customer wires are landed with grounding and bonding in place. Use of the disconnect alone is not sufficient for PSE to leave the service energized for safety concerns.

---

## Modified services

PSE classifies work done on a service as a “modified service” when a customer requests a change in their secondary service that alters its current point of delivery or location to a new point of delivery without requiring the replacement of the entire service entrance conductor.

A modified service still must meet all the new service installation requirements. You are responsible for equipment from the meter socket into your building.

An electrical work permit must be present on your property for all work done on the customer side of the meter. You must apply for the permit before the work is started. After the work is completed, your local government agency must inspect the work before PSE can energize the service.

We know at times the electrical inspection is not completed or feasible by the time we arrive to reconnect your service. For modified services, if the permit is present and the work is completed, but the inspection has not been done, the service may still be energized by PSE if the work looks safe, clean, and completed. The inspection can take place the following day.

The customer requesting a modified service shall be required to pay PSE the costs of altering, transferring, or extending the existing electric service to the new point of delivery or location.

Modified service requirements can vary depending on the scope of the change (see Table 8).

Table 8

Example of overhead and underground modified service

Customer request	PSE and Customer responsibilities
<p><b>Overhead Modified Service</b></p> <p>Your electric meter base is being replaced with a new meter base, and will be located a few feet away from where old meter base was. You will also replace the existing mast and weatherhead.</p>	<ul style="list-style-type: none"> <li>• Notify your CCS Representative if you are changing panel amperage rating or increasing the connected load within your building.</li> <li>• You or your electrician must arrange for PSE to remove the wire from the point of attachment and make permanent connection to the new weatherhead. You must give PSE adequate notice of your intentions, typically 5 to 10 working days prior to needing your service energized.</li> <li>• An electrical permit must be present and visible prior to PSE energizing your service.</li> </ul>
<p><b>Underground Modified Service</b></p> <p>Your mobile home is being relocated and you need to move your meter pedestal closer to the new location. Or, you are remodeling and have to change the electrical panel and/or meter location.</p>	<ul style="list-style-type: none"> <li>• Notify your CCS Representative if you are increasing the load or capacity of your meter panel.</li> <li>• You are responsible for digging to the new pedestal location.</li> <li>• You must expose PSE's wire or conduit at the old pedestal location. This is where your new trench will start.</li> <li>• A new pedestal installation permit must be present and visible on-site prior to calling PSE to perform the work. You must give PSE 5 to 10 working days' notice prior to calling PSE to perform the work.</li> </ul>

# Glossary

**Approved** – Acceptable to the authority having jurisdiction.

**Backfill** – Native soil or soil brought in from another area, free from sharp objects, rocks, scrap building material, and corrosive material.

**Clearance** – A set distance between two objects.

**Conduit** – A listed or approved wireway with a smooth interior surface to permit easy drawing-in of the electrical conductors. A conduit may be metallic or nonmetallic, depending on its usage, in accordance with codes and Puget Sound Energy Standards.

**Current Transformer (CT) Enclosure** – A sealable cabinet designed for surface or flush mounting, and provided with a frame or trim in which doors or removable covers are hung.

**Customer Construction Services (CCS) Representative** – The designated representative of Puget Sound Energy, responsible for design and/or coordination of new or revised services to PSE customers. The CCS Representative responds to inquiries on policies, standards, practices, rates, and energy utilization.

**Customer Generation** – A generation facility installed by PSE customers that are interconnected and operated in parallel with PSE's electric distribution system through the electric service meter (net meter).

**Demand** – The maximum average kilowatt load used by the customer for a specific period of time during the billing period.

**Direct Burial** – The installation of electrical conductors in a trench, without the use of conduit.

**Disconnect Switch** – A single blade-type, visible and lockable disconnect.

**Drip Loop** – A loop formed in overhead secondary conductors at the weatherhead to prevent water from entering into the service entrance conduit and equipment.

**EUSERC** – Electrical Utility Service Equipment Requirements Committee

**Ground Rod** – A ground electrode made up of a rod not less than 8' in length and 5/8" in diameter, typically made of zinc or copper coated steel. More information on ground rods is available in the National Electric Code.

**Guy** – Cable or brace used to relieve the strain of overhead conductors on masts and poles.

**Inverter** – An electronic device used to change dc current into ac current.

**Locked Rotor Current** – Locked rotor current is associated with the amount of current drawn from your electric service necessary to start an electric motor. Typically, a motor draws its maximum current to transition the rotor from being stationary, or stopped, to spinning. Once the rotor of a motor is spinning, the current needed to power the motor is typically reduced. Locked rotor current is sometimes referred to as Locked Rotor Amperes, In-Rush Current, or Starting Current. Not all motorized devices have a unique starting current.

**Manual Block Bypass (Circuit-Closing Block)** – A provision for paralleling the meter circuit, allowing the meter to be removed without interrupting service to the customer.

**Meter Jaw** – A spring-loaded receptacle installed inside a meter socket, interfacing the terminals of the meter to the source and load conductors of the service.

**Meter Loop** – Any provision in which an electrical meter may be installed. Does not include the service disconnect device.

**Meter Pole** – A pole which supports the metering equipment owned and maintained by the customer.

**Meter Base/Socket** – The mounting device consisting of meter jaws, connectors, and enclosure for accommodating socket-type meters. The mounting device may be either a single socket or a trough to accommodate more than one mounting unit.

**Metering Equipment** – Any equipment associated with measuring electric energy.

**Municipal or State Inspector** – The qualified representative of a city or the Washington State Department of Labor and Industries, who has been authorized by governmental agencies to inspect electrical service installations on their behalf.

**NEC** – National Electrical Code

**NESC** – National Electrical Safety Code

**Net Meter** – A PSE meter through which the customer generation is interconnected to the PSE electric distribution system. Net meters measure both energy delivered from PSE to the customer and energy returned to PSE from the customer.

**Neutral** – The grounded conductor in a single-phase, three-wire or three-phase, four-wire system. The service conductor that is at zero potential to ground.

**Point of Attachment (Point of Service)** – The point at which Puget Sound Energy's service conductors are attached to the customer's premises by an approved insulated clevis.

**Point of Delivery** – The connection point of the meter base, on the customer's premises, where Puget Sound Energy's circuit and the customer's system are interconnected.

**Primary Voltage** – The higher voltage, before transformation, used to distribute electrical energy through neighborhoods and local areas. Normally in excess of 600 V.

**Production Meter** – A PSE meter measuring energy production from customer generation sources.

**RCW** – Revised Code of Washington

**Seal** – The locking device used to secure meter and/or service entrance equipment to assure safety and security for the unit.

**Secondary Voltage** – The lower voltage, after transformation, used to supply the customer with electrical energy. Normally less than 600 V.

**Self-Contained** – In reference to meter sockets: a device designed and rated to continuously carry the entire capacity of the service entrance equipment through the meter.

**Service Entrance Conductors** – Those conductors which extend between the customer's load center and point of delivery.

**Service Entrance Equipment** – Service conduit, conductors, weatherhead, meter base, enclosures, service disconnect, and load center.

**Service Mast** – The conduit above the meter used to provide mechanical protection for the service conductors and to support the service drop from Puget Sound Energy's system.

**Supply Side Tap** – A connection that is made on the line or utility side of the main service disconnect breaker.

**Temporary Service** – An electrical service installed by Puget Sound Energy to provide power to a customer on a temporary basis (12 months or less).

**UL** – (Underwriters Laboratories) A nationally recognized test laboratory which lists materials it has tested and accepted.

**UULC** – Utilities Underground Location Center

**WAC** – Washington Administrative Code

## Notes

---

## Notes

---



