

System Diagram Guide

System Diagram Guide:

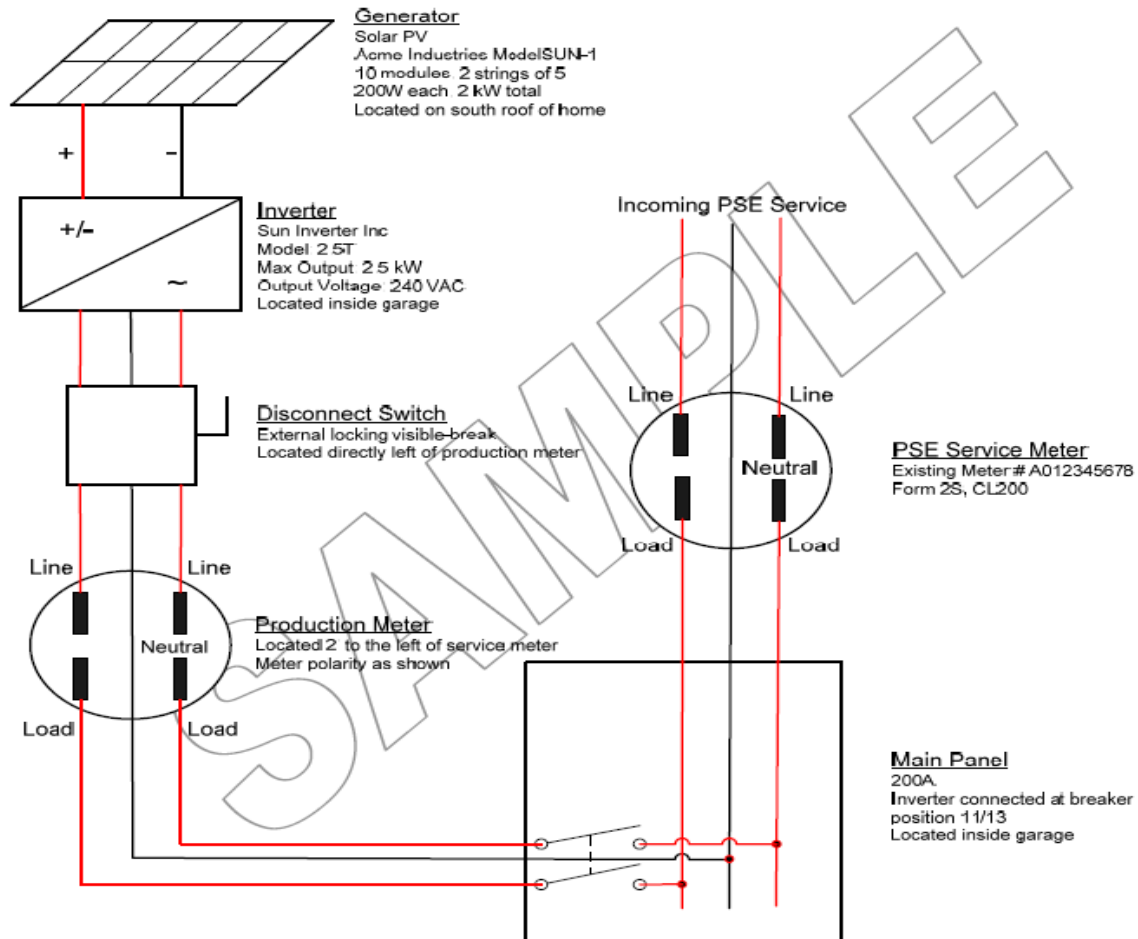

One-Line Standard Grid-tied System - 240V Inverter

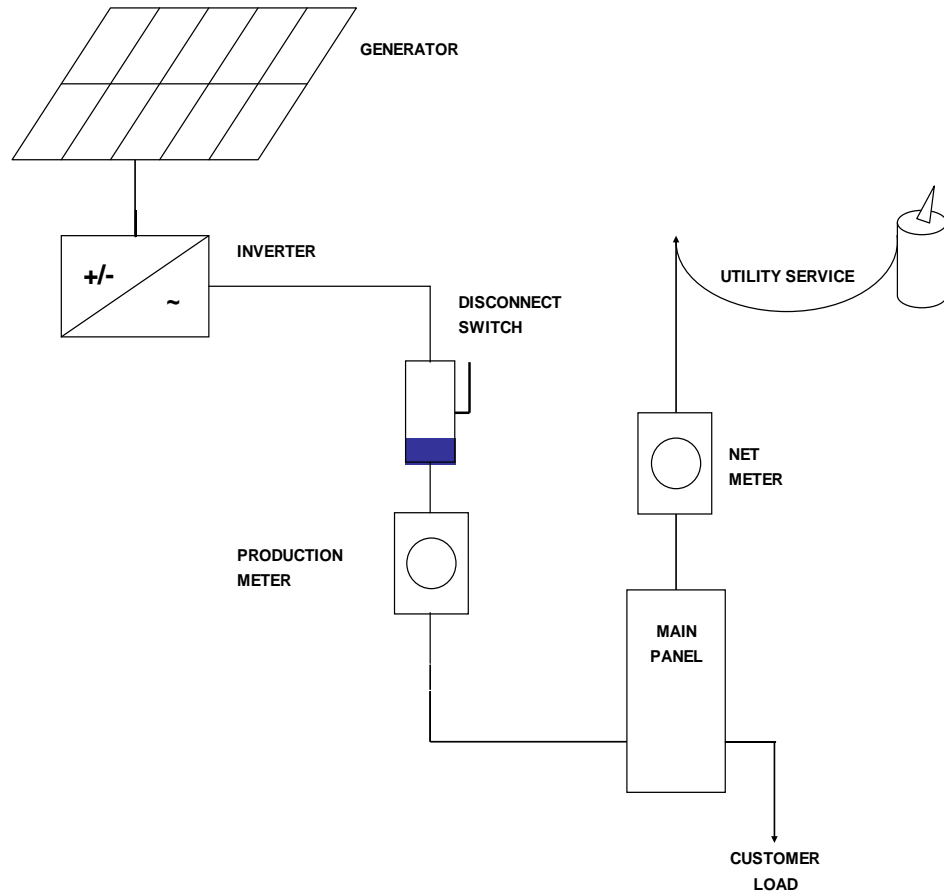

Battery Back-up with 120V Inverter and Emergency Load Sub Panel

“Outback Power” Style (120V only)

**Production = A + B - C
in a single Form 12S meter**

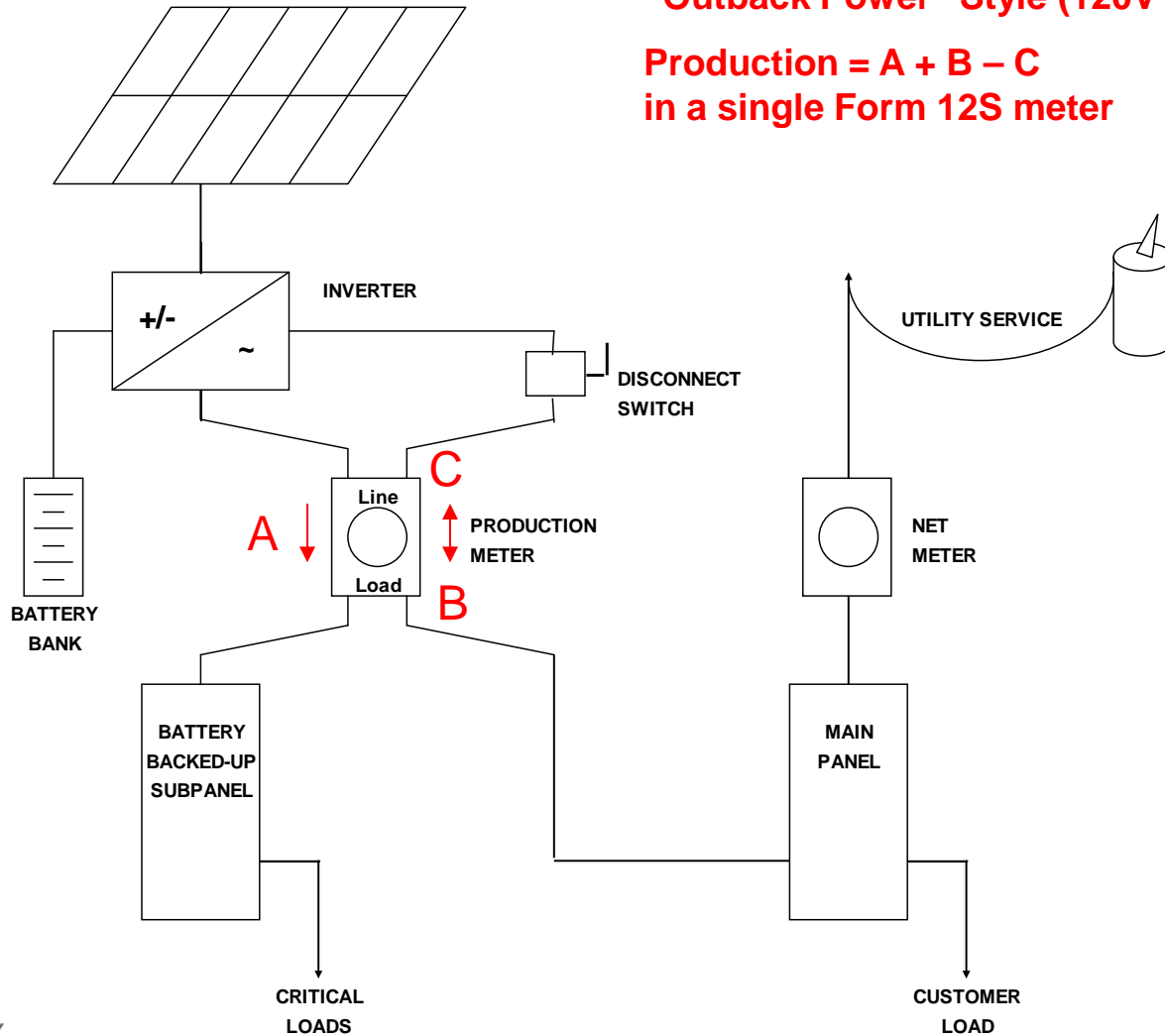

Battery Back-up with 240V Inverter and Emergency Load Sub Panel (Option 1)

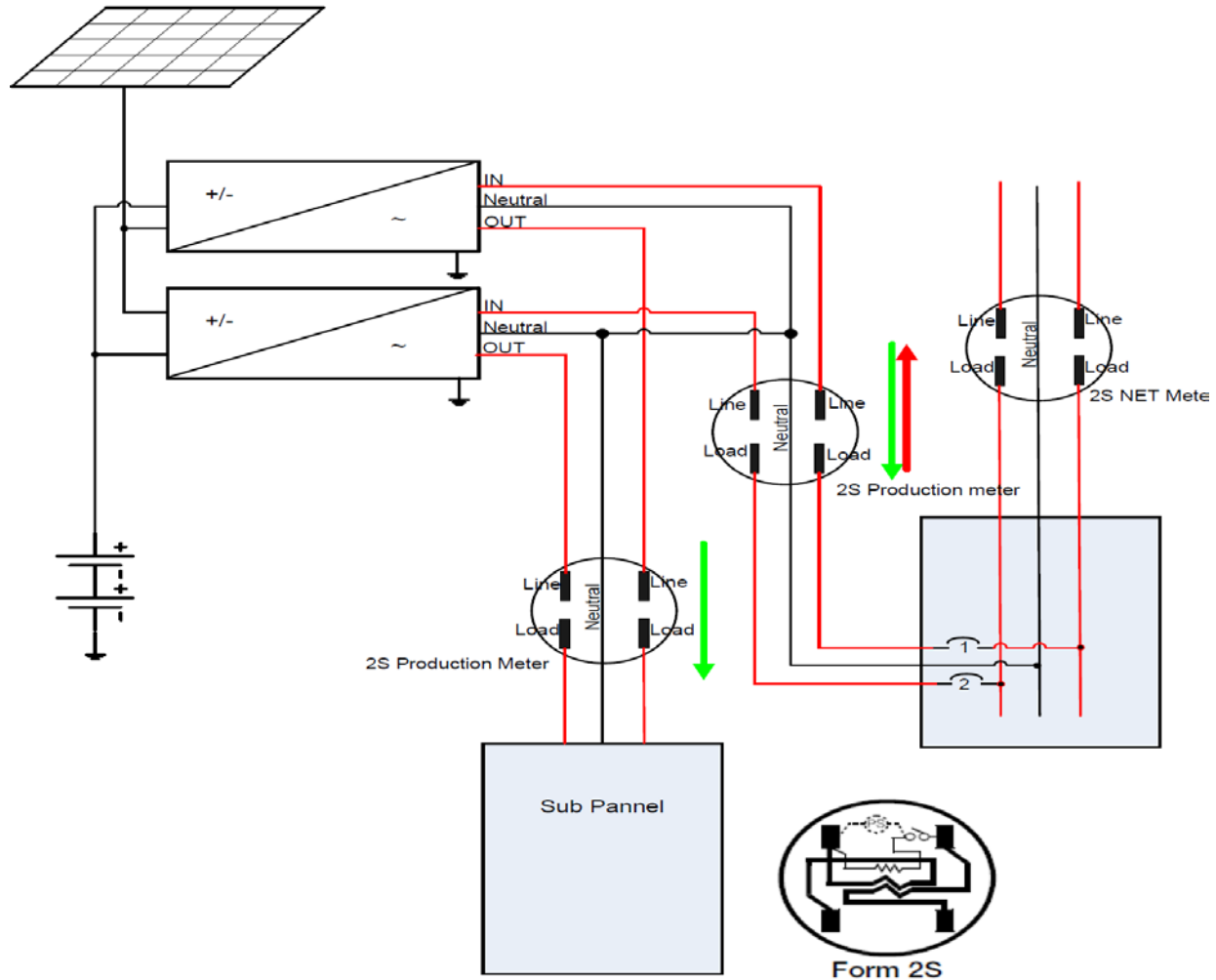

Battery Back-up with 240V Inverter and Emergency Load Sub Panel (Option 2)

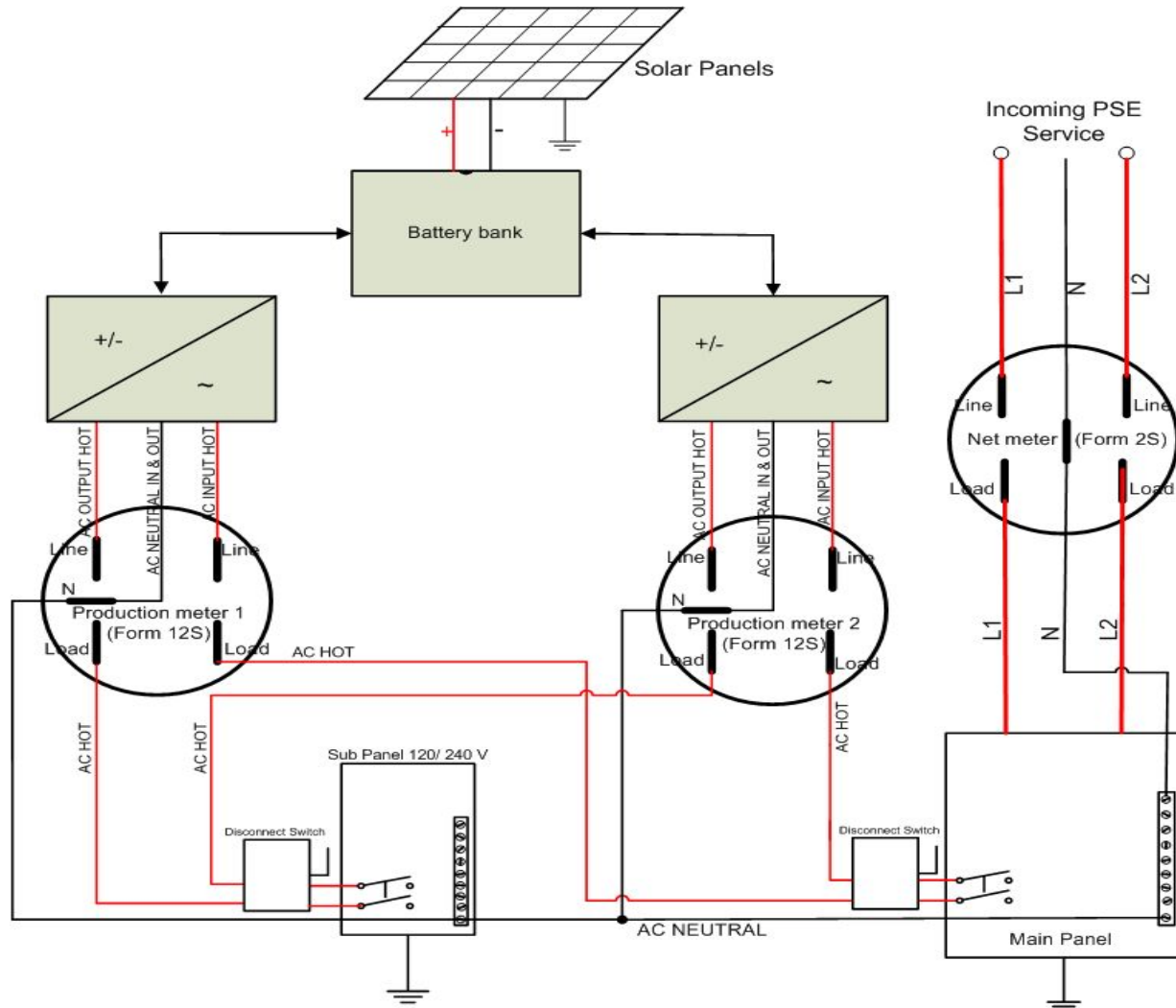

PV System with Battery Backup – Twin 12S Meter Configuration

Battery Back-up with 240V Inverter and Emergency Load Sub Panel (Option 3) “Sunny-Island” Design

